

emcogroup

Designed for your profit



HYPERTURN 45 - G3

High-performance turning center
for complete machining

TURNING
EMCO-WORLD.COM

HYPERTURN 45 - G3



1 UPPER TOOL SYSTEM

- 12-station VDI25 tool turret with milling drive (0 – 8000 rpm)
- 12-station / 16-station BMT45P tool turret with direct drive (0 – 12000 rpm)
- Servo-controlled
- Up to 50 bar coolant pressure as a standard

2 MAIN SPINDLE

- Integrated, water-cooled spindle motor (ISM)
- High drive power: 15 kW
- High torque: 100 Nm
- Wide speed range: 0 – 7000 rpm
- Extremely dynamic
- Bar capacity \varnothing 45 (51) mm

3 COMPACT MACHINE DESIGN

- Minimal floor space

4 LOWER TOOL SYSTEM

- 12-station VDI25 tool turret with milling drive (0 – 8000 rpm)
- 12-station / 16-station BMT45P tool turret with direct drive (0 – 12000 rpm)
- Servo-controlled
- Up to 50 bar coolant pressure as a standard



Machine with optional equipment



Starter pinion
(42 Cr Mo 4)



Hip joint cup
(Titanium alloy)

Now in its third generation, the new HYPERTURN 45-G3 stands out by merging a significantly larger work area with compact design. This enables the integration of a 12- or 16-station turret with direct drive and BMT interface. The basic machine still features a VDI25 servo turret with quick-change interface. Thus many customers may continue to use their existing tool holders. And it now offers a speed range of 0 – 8000 rpm. The tried and tested two-piece base structure remains unchanged. This makes it possible to achieve high precision and thermostability despite increased dynamics. The machine is primarily used in the field of general machine and equipment engineering, but also in high-precision areas such as medical technology and the jewelry industry.



5 Y-AXIS

- +/- 40 mm stroke
- 90° implemented in the machine construction
- Large distance between guides
- Stable and compact construction

6 CONTROL UNIT

- Ergonomically designed
- +/- 100 mm height adjustment
- Sinumerik 840 D sl with emcoCONNECT and 22" multi-touch screen
- Fanuc 31iB with 22" multi-touch screen

7 CHIP CONVEYOR

- Hinge type chip conveyor
- 1100 mm ejection height
- Integrated 300 litre coolant tank
- Turret pumps: 2 x 14 bar
- Flushing pumps: 2 x 3.7 bar

8 COUNTER SPINDLE

- Integrated, water-cooled spindle motor (ISM)
- High drive power 15 kW
- High torque: 100 Nm
- Wide speed range: 0 – 7000 rpm
- Highly dynamic
- Bar capacity \varnothing 45 mm (optional)



Dental contra-angle handpiece
(Brass)



Switching shaft
(Aluminum)

Structure

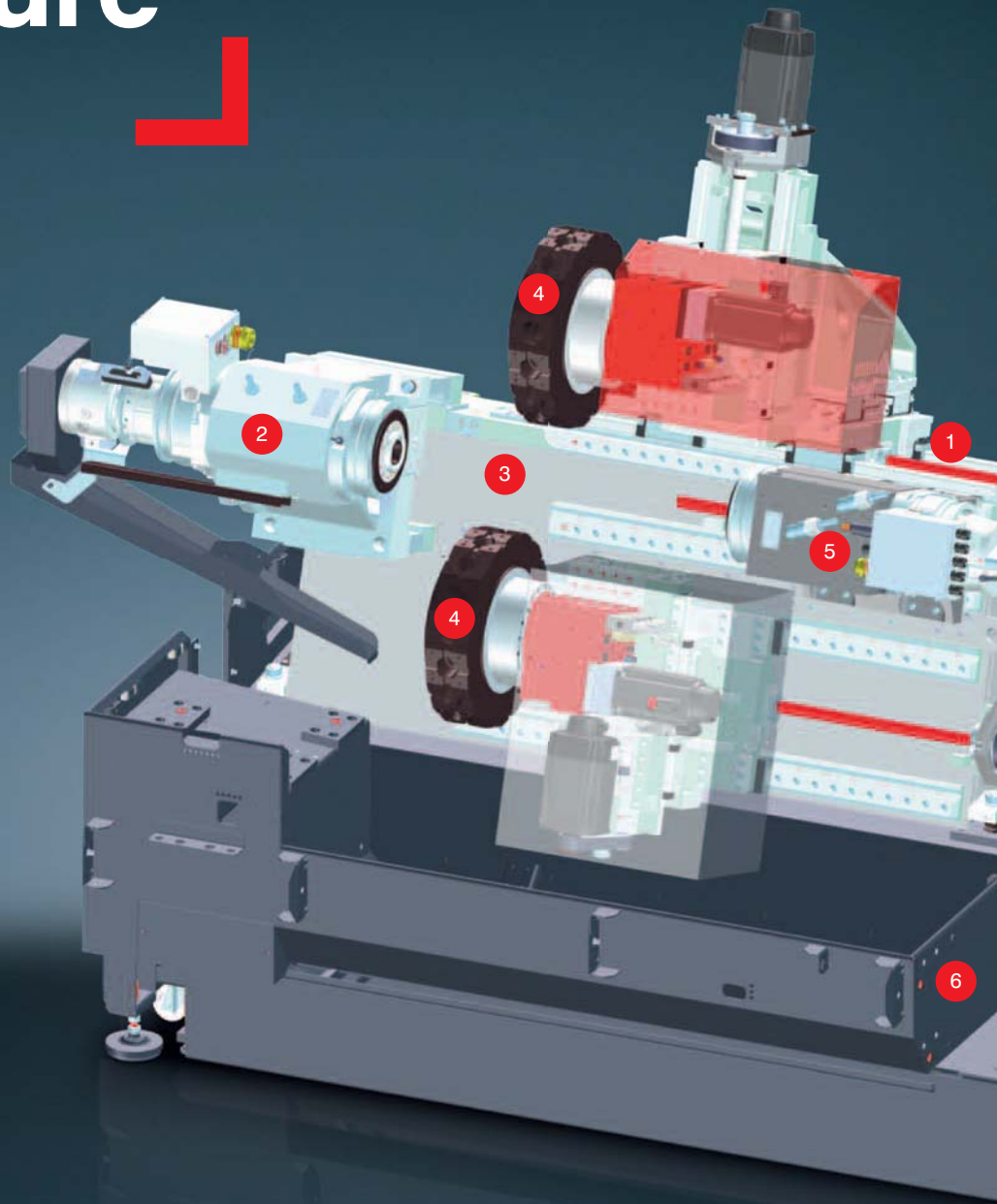

1 ROLLER GUIDES

- In all linear axes
- Preloaded and backlash-free
- High rapid motion speeds
- No wear
- Minimal lubrication required

2 MAIN SPINDLE

- Wide speed range
- C-axis for milling operations
- Spindle clamp
- A2-5 spindle nose
- Hollow clamping system $\varnothing 45$ (51) mm
- Programmable clamping stroke monitor

3 MACHINE BASE

- Extremely torsion-resistant welded-steel construction
- Compact design
- Maximum thermostability
- Filled with vibration-absorbing material

Performance and torque

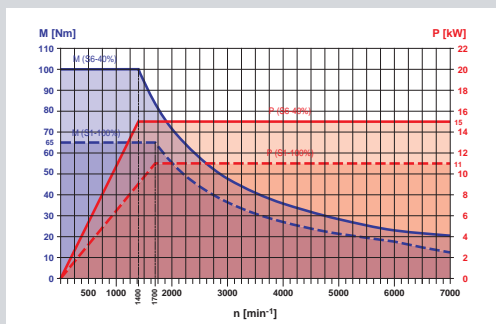

HYPERTURN 45-G3 main spindle / counter spindle

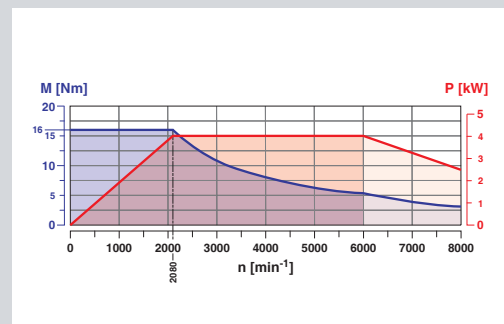

VDI25 tool turret with driven tools

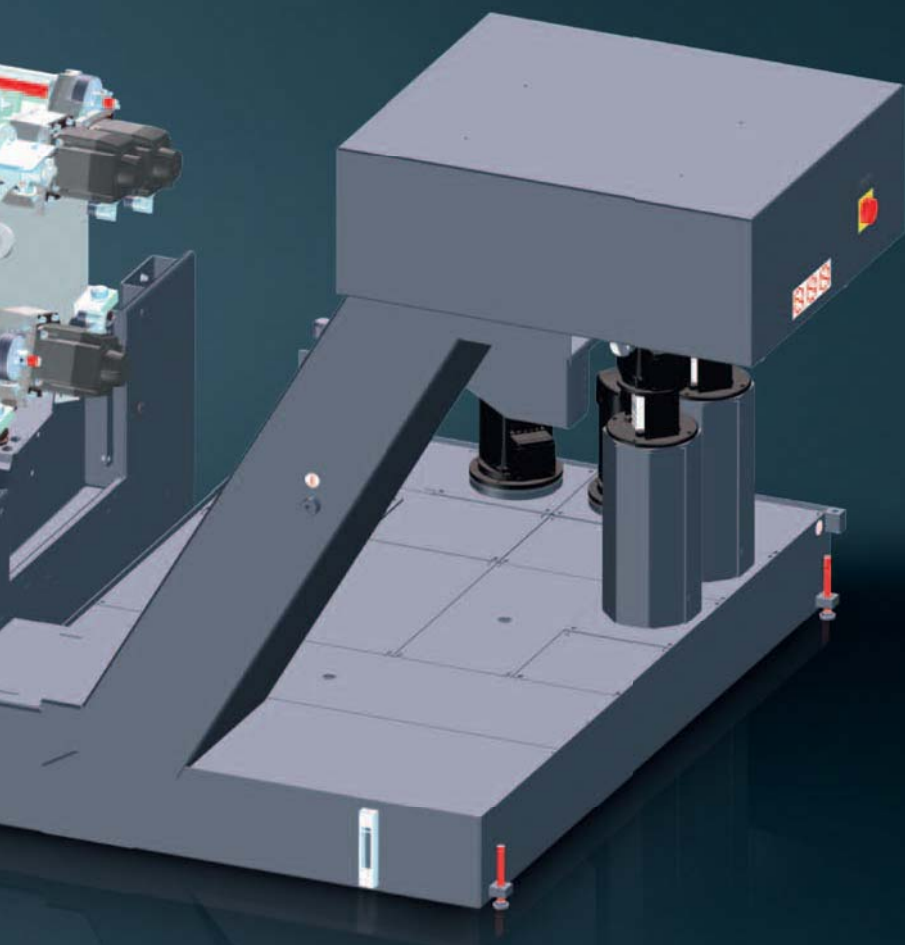

4 TOOL TURRET

- 2 x 12-position VDI25 turrets
- 2 x 12-station/16-station turrets BMT45P
- No alignment of the tool holder
- Can be used flexibly on both spindles
- Swivel speed adjustable with override

5 COUNTER SPINDLE

- Wide speed range
- C-axis for milling operations
- Spindle clamp
- A2-5 spindle nose
- Full clamping system with parts ejector \varnothing 45 mm
- Programmable clamping stroke monitor

6 MACHINE STAND

- Solid welded-steel design
- Thermally separate from the machine base
- Filled with vibration-absorbing material
- 100% sealed against coolant leaks

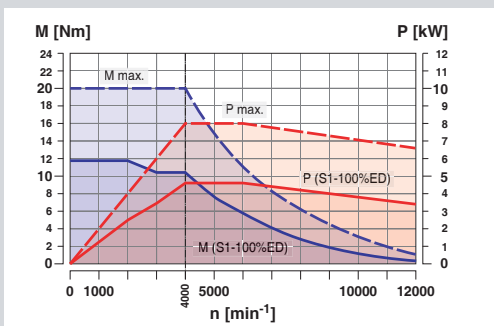

BMT45P tool turret with direct drive



Work area. The generous work area provides space for several tools on both turrets and ensures a continuous chip flow even during virtually unmanned production. Additional coolant pumps and a sophisticated pipe system clear the chips into the chip conveyor.

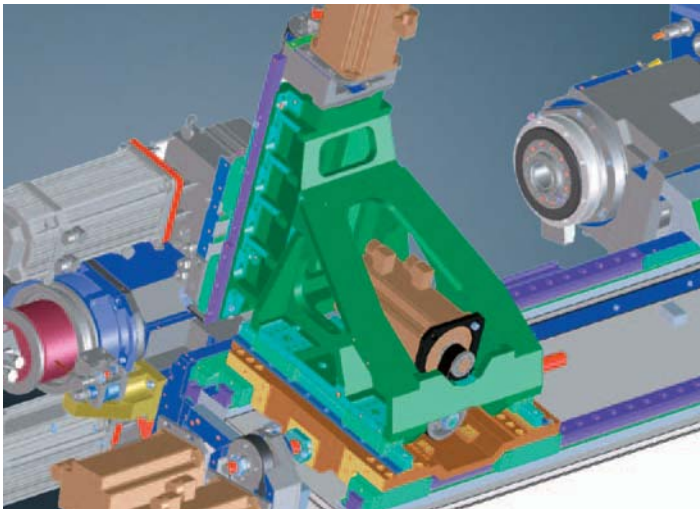

Y-axis. The Y-axis is integrated into the basic machine structure and stands at 90° to the X-axis. Extremely short projections form the basis for solid turning and drilling operations and also for milling operations without interference contours.

HYPERTURN 45 - G3 Technical

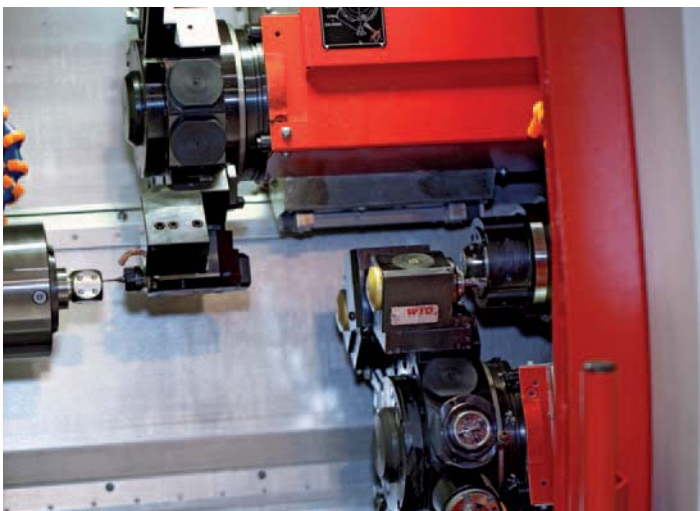

Tool turrets. Rapid 12-fold servo turrets with very short cycle times for standardised VDI25 tools. All stations may accommodate driven tool holders for drilling, milling or thread-cutting operations. The operator may influence the swing speed at any time.

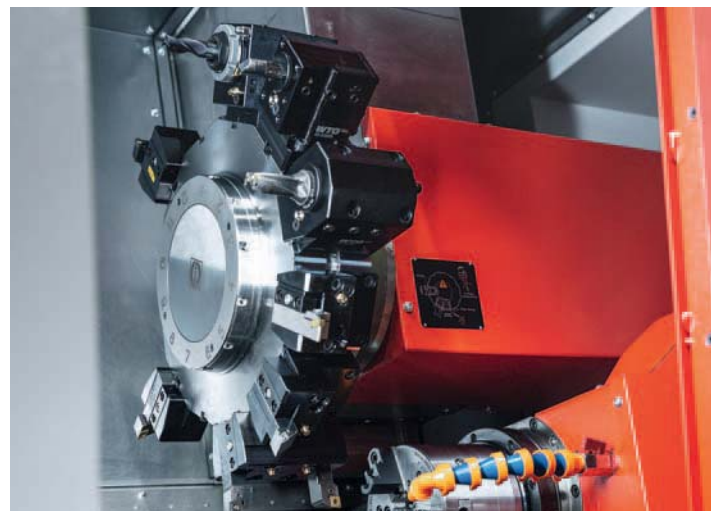

BMT-turret. For economical production of complex turned/milled parts with mainly milling share, there is optional the BMT-turret with water cooled direct drive. With max. 12000 rpm, 20 Nm and 8 kW, this turret offers optimal prerequisites for the complete machining.



Main spindle. The 15 kW motor spindle with its integrated water cooling system provides high dynamics but low thermal displacement. A high-resolution shaft encoder provides the optimum conditions for accurate contour milling and drilling.

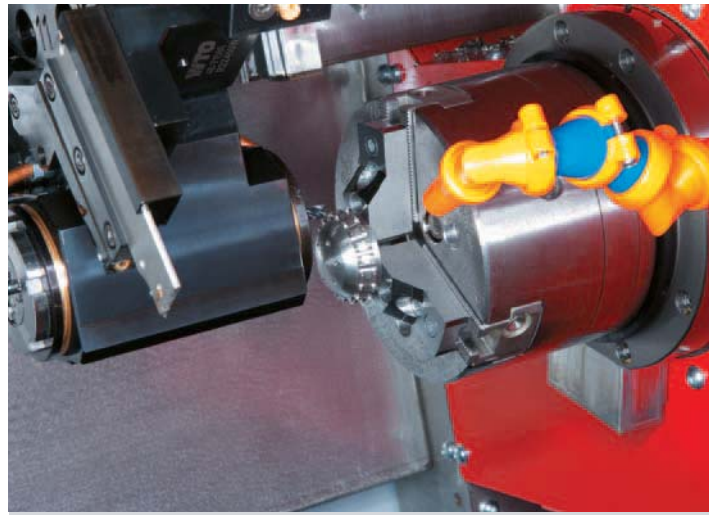

Counter spindle. A 15 kW, water-cooled spindle motor ensures dynamic performance and high levels of precision. The standard machine is equipped with a coolant-fed parts ejector. This places the finished workpieces in the parts catcher and at the same time clears the clamping surface from chips. Additionally, a flexible coolant pipe is mounted above the counter spindle for cleaning.

Highlights

Highlights

- Large work area
- Highly dynamic drives in all axes
- Two powerful work spindles
- 12-station/16-station tool turret with impressive milling performance
- Stable Y-axis with 80 mm travel
- emcoCONNECT process assistant for Siemens 840D sl
- Fanuc 31iB with 22" multi-touch screen
- Compact dimensions
- Made in the Heart of Europe



Parts catcher. The HYPERTURN 45's pneumatic parts catcher is controlled using M-functions. When needed, it traverses to the front of the work area and travels to the spindle center. The finished part is removed from the clamping device and transferred to the catcher tray. The parts catcher then moves back to its initial position and the part is tipped into a catching box or onto a conveyor belt.



Finished parts conveyor. The parts catcher deposits the finished parts on an accumulating conveyor with a usable storage area of 340 x 750 mm. Since the belt is clocked, the parts – which are often very complex – are kept from falling on top of each other.



DASHBOARD – For a Quick Overview of the Machine Status

Clear and compact processing of all relevant machine and NC data depending on the configuration of the machine (number of tool systems, spindles, ...) and the active operating mode (JOG, MDA, AUTO). Know at a glance whether everything is OK or whether the machine operator will be required to interact.



emcoCONNECT's hardware basis is a 22" industrial touch control panel combined with an industrial PC (IPC).

Highlights

- Direct interaction between EMCO Apps and the control
- Intuitive user interface optimized for touch control
- Range of available applications is continuously being expanded
- Customised and project-specific applications
- Optimized for the EMCO machine range
- emcoCONNECT allows for easy and quick configuration and updating

er” for fire production flow

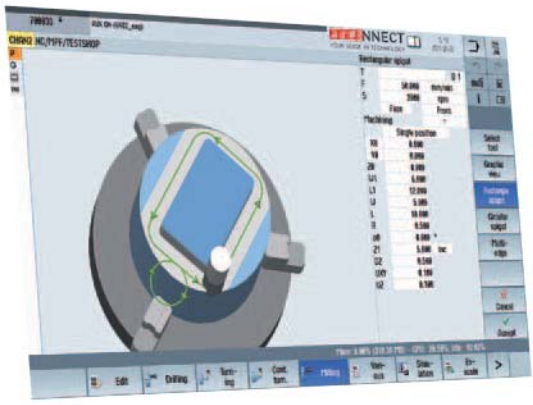

SINUMERIK - the Control and the Machine’s Centerpiece

Thanks to the App Launcher operators may switch between the emcoCONNECT Apps and the control at any time. All it takes to do so is a click on the emcoCONNECT logo. To improve the work processes on the machine the control can, as shown in the picture, be operated in full screen mode or in interaction with practical apps (sidebar).

MACHINE DATA – All Data related to Productivity at a Glance

Operating data collection to inform the user about the current production status and OEE (Overall Equipment Effectiveness) values full screen or sidebar.

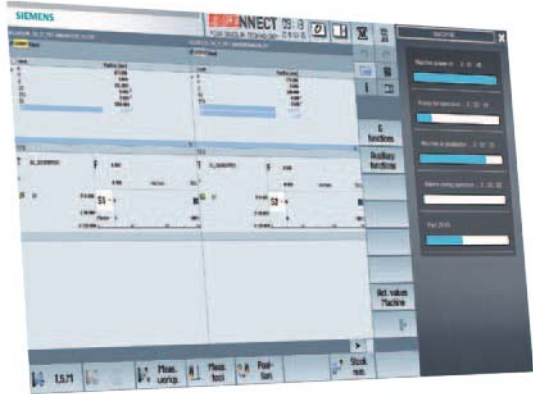

DOCUMENTS – A Digital and Expandable Document Collection Customized to Suit Your Individual Needs

To display PDF documents such as machine documentations, programming instructions, process descriptions ... Including favorites management - full screen or sidebar

Virtual workflow.

Real benefits.

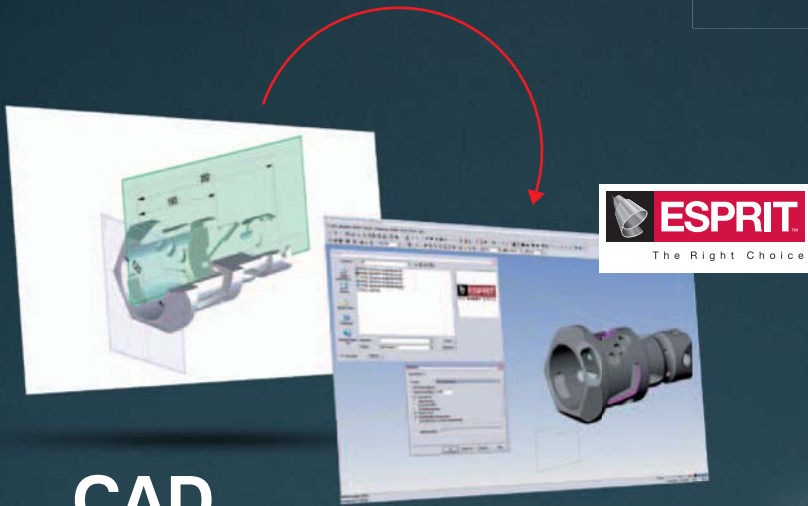

CAD

Direct CAD data import

- AutoCAD (DWG)
- Parasolid®
- Solid Edge®
- Solid Works®
- ACIS® (SAT)
- Optional interfaces: CATIA®, Pro/ENGINEER®, STEP, STL, ...

CAM

- 2-22 axis turning
- 2-5 axis milling
- Multi-tasking of turning and milling
- 3D machine space simulation
- Certified post-processors

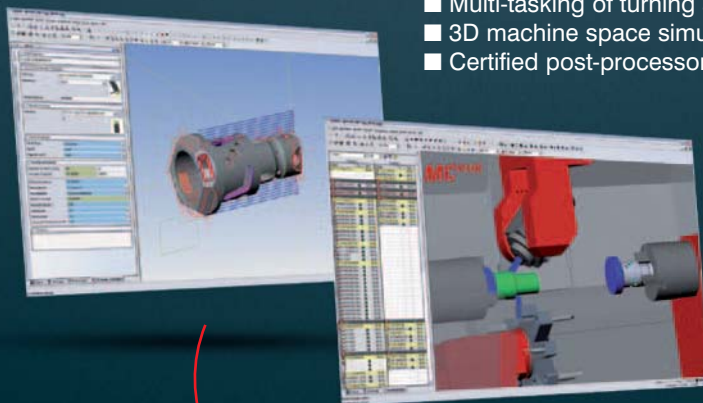

fits.

The Esprit CAM system offers high flexibility and process security, a comprehensive selection of machining cycles, maximum tool control, and cross-machine technology for your entire production facility. EMCO CPS Pilot provides for a 1:1 mapping of the real machine for defining and testing processes, optimizing machining sequences, and training new operators.



CPS

- 1:1 simulation with collision detection
- Direct connection to CAM ESPRIT
- Process optimization
- Reverse simulation of existing NC codes
- Reduction in scrap rates
- Training on the virtual machine
- Simulation of loading systems (e.g. EMCO gantry loader)

emcoCPS | Pilot
Die virtuelle Maschine

Production

- Reduction in set-up costs
- Reduction in downtimes
- Reduction in repair costs
- Optimum machine utilization



EMCO TOP LOAD.

The premium class.

Quality by the meter. The EMCO TOP LOAD series was designed to automatically load 3-meter long bar stock into EMCO machines. Loaders are available for diameters of 8 – 42 mm and 8 – 50 mm. The oil coolant-fed loading channel, lined with plastic shells, reduces vibrations to a minimum, even at high speeds. Bar stock is fed in via a servo motor which controls both the speed and feed force. A patented guidance system with several guidance rests guarantees optimum feed quality. Time-consuming conversions and channel changes are no longer necessary. The bar loader can be switched from one diameter to another in just a minute or two.



EMCO TOP LOAD 8-42/3200 in SINGLE-LEVEL version

In SINGLE LEVEL mode. Bar stock is laid on a slanted feed track (280 mm) and falls into the guide channel one by one. Optionally, the MULTI-LEVEL version is also available. In this case, bar material can be stored on several levels (3x 300 mm), thus maximizing manless operation.

The EMCO short bar loaders. Universal and powerful.

Short and to the point. The EMCO SL1200 is the perfect solution for automatic feeding and loading of cut-to-length bars. The key advantages are a small footprint and rapid loading times resulting from shorter strokes.

The technology. The SL1200 can be used immediately as a “plug-and-play” solution. Their extremely small footprint enables processes to be automated even if space is tight. Apart from complying with the latest safety requirements, it is easy to operate and moveable for service purposes. Besides, it can comfortably be incorporated into the production process using the machine control's programme input masks. Minimum setup efforts are required when switching over to other bar diameters.

Technical data	SL1200
Bar diameter	Ø 8 – 95 mm
Max. bar length	1200 mm
Min. bar length	150 mm
Material storage length	approx. 560 mm
Feed rate	0 – 60 m/min
Bar change time	approx. 15 sec.
Dimensions (L x W)	1700 x 1250 mm
Weight	approx. 500 kg

The benefits

- Smaller footprint
- Easy to use
- Short feed times
- Fast, straightforward changeover
- Option to load individual workpieces
- Central diameter adjustment
- Dedicated control
- The loader operates without oil
- Ergonomic EMCO design



EMCO SL1200. Space-saving and cost-effective bar loading magazine. Operation and programming could not be easier. May also be used for loading single items through the lathe's main spindle.



Material storage. The material storage surface with a length of 560 mm is arranged at the rear of the bar loader in a manner with no influence whatsoever on the space available. Depending on the diameter it is possible to store a different number of short bars.

EMCO swing loader. The integrated solution.

Tailor-made solutions. For preformed blanks and parts with a diameter larger than the spindle capacity, we offer an integrated swing loader for fully automated loading and part removal. This has been designed to form a harmonious single entity with the machine. The machine control system takes care of positioning. A short bar loader and a 3-meter bar loader are available from EMCO for workpieces from bar stock.

1 SWING LOADER

2 STORAGE CONVEYOR BELT

3 GRIPPER



Advantages

- Fully automated loading and unloading of the workpieces
- Short loading and unloading time
- Flexible for shaft or flange parts
- Oriented loading into the clamping device
- Simple programming via the Sinumerik control
- CNC-controlled movements

Maximum output – Minimum space required.

The EMCO swing loader is a universal loading system for all types of preformed blanks. It can be customized individually to the customer's requirements using numerous gripper and handling systems. How we do it: we standardize the components but create a customized solution. The result: a custom-tailored machine for the same price as a standard unit.

Blank part feeding systems

Feed systems specific to particular blanks allow pre-formed workpieces to be loaded into the work spindle in the right direction, allowing manufacturing with minimal personnel requirements.



High-capacity timed conveyor system for correct directional loading of pre-formed blanks.

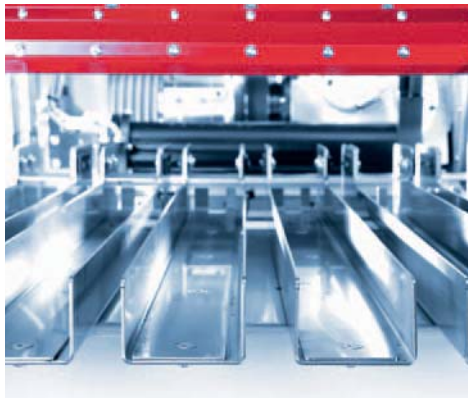

Multiple infeed chutes for loading rotationally-symmetrical blanks; the length of the blanks determines the number of infeed chutes.



Timed conveyor system with V-supports for preformed shaft parts of various shapes.



Multiple infeed chutes for loading rotationally symmetrical blanks. A sensor monitors the availability of blank parts for each infeed chute.

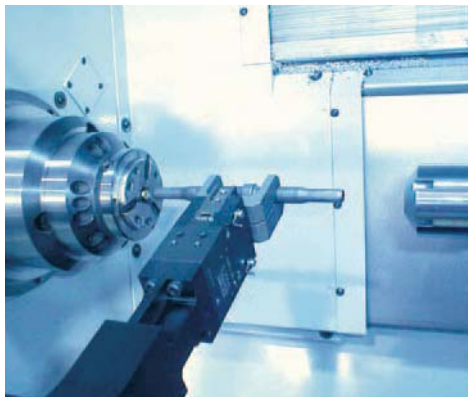

Shaft gripper for automatically loading pre-formed shafts.

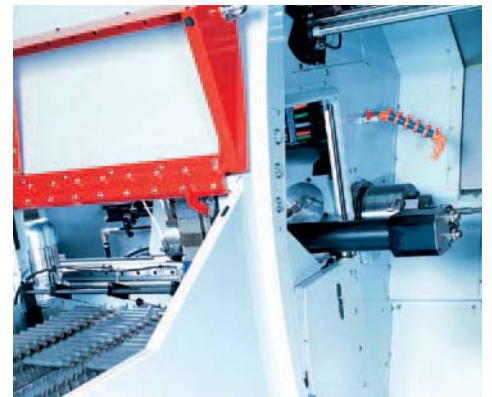

Fully automatic shaft loading. Feed-in via a conveyor belt, removal via the finished parts pick-up device.

Customization

A wide range of gripper and handling systems is available.



2-finger gripper with 180° rotary module for loading vertically fed blanks

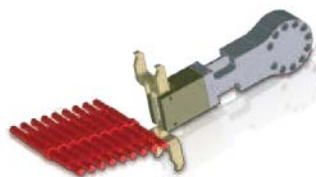

2-finger toggle lever gripper for loading shaft parts

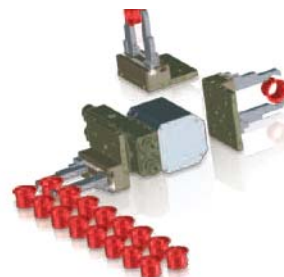

Parallel grippers with 180° rotary module for loading shaft parts (1st and 2nd clamping cycle)

The EMCO gantry loader. Individual process optimization.



Advantages

- Fully automated loading and unloading of the workpieces
- Multi-channel Sinumerik control incl. user cycles
- Seamless interplay between the machine tool and the loading device
- Varied possibilities of customer-specific adaptation
- Possibility of integration of measuring station, signing station, cleaning station, etc.
- Short non-productive times due to a loading hatch

Automatic Return on Investment

Workpiece magazine

Blank-specific pallet attachments enable oriented loading of blanks into the machine and increase the parts stock for unmanned production. Changeover times are reduced or eliminated thanks to the perfect adjustment to the customer's parts.

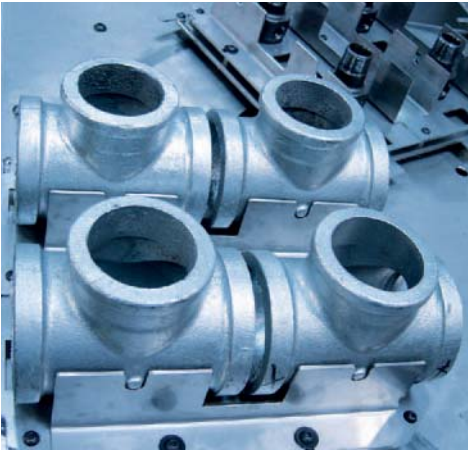

4-station pallet attachment for tees



6-station pallet attachment for articulated brackets

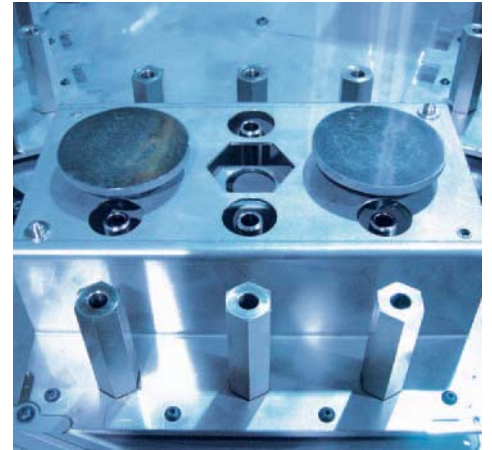

Multi-pallet attachment for a family of parts



4-station pallet attachment for valve caps



20-station pallet magazine with customer-specific pallets

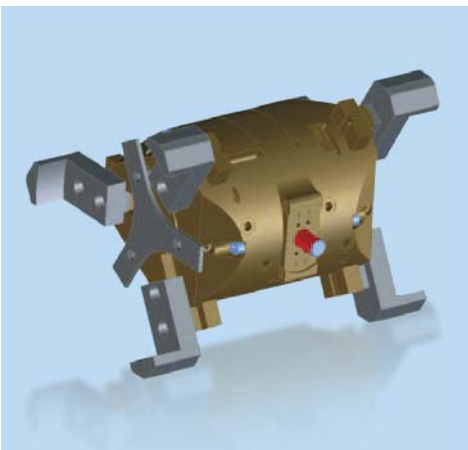

2 x 3-jaw double gripper head



4 x 3-jaw gripper head

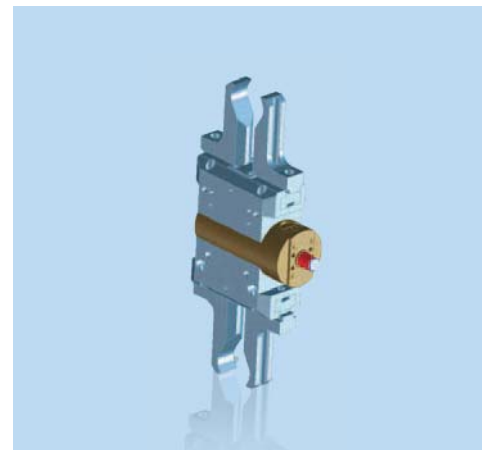

Shaft gripper head

Options

There are many accessories and options available to help further customize the HYPERTURN 45 - G3. A generous selection of tool holders allows a wide range of machining options, including those you would not immediately associate with a turning center, including deep hole drilling, intermeshing, engraving, groove slotting and many more.

Antrieb 1		Antrieb 2		Antrieb 3	
BRUCH	Grenzalarm	BRUCH	Grenzalarm	BRUCH	Grenzalarm
0.5	12.2	0.9	0.6	0.8	32.3
150	00	120	00	120	00
493	55	58	2	104	49
					25
					102
					101
					99
					100
					101
					103
					33%
					33%
					68%
					94%
					35%
					35%
					36%

EMCO tool breakage monitoring system

The tool status is monitored by evaluating the load on the various axis drive motors. Excessive loads point to wear or broken tools. Too low a load indicates a tool is missing.



Band filter system with high-pressure coolant pumps

A coolant pressure of 25/40/60/80 bar can be set as necessary. This enables coolant-fed drilling and milling tools to be used to their best advantage.

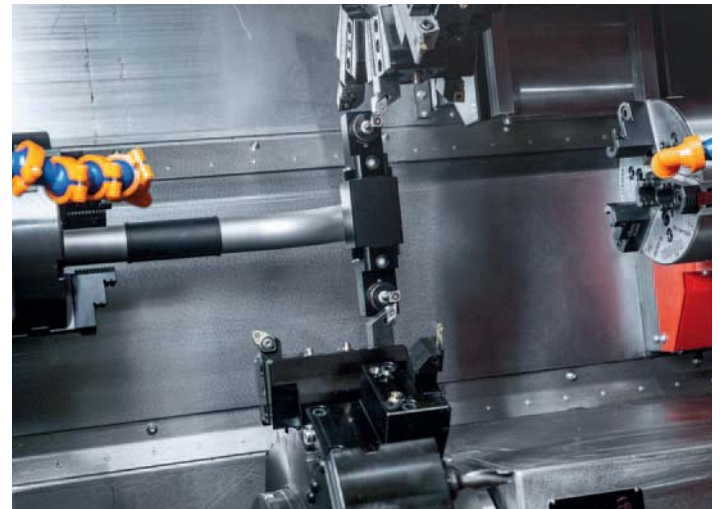

Tool gauge

The tool gauge allows tools to be measured quickly and accurately on both turrets in the work area. It is mounted manually in the holder in the work area and, after use, is replaced in a storage space in the machine housing.



Unloading through the counter spindle

Long, thin workpieces with diameters of up to 45 mm can be removed from the machine using the counter spindle. Parts are mostly stored on a sloping surface or, if necessary, also on a controlled conveyor to prevent any kind of damage occurring.

Machine layout HT45-G3 with EMCO SL1200

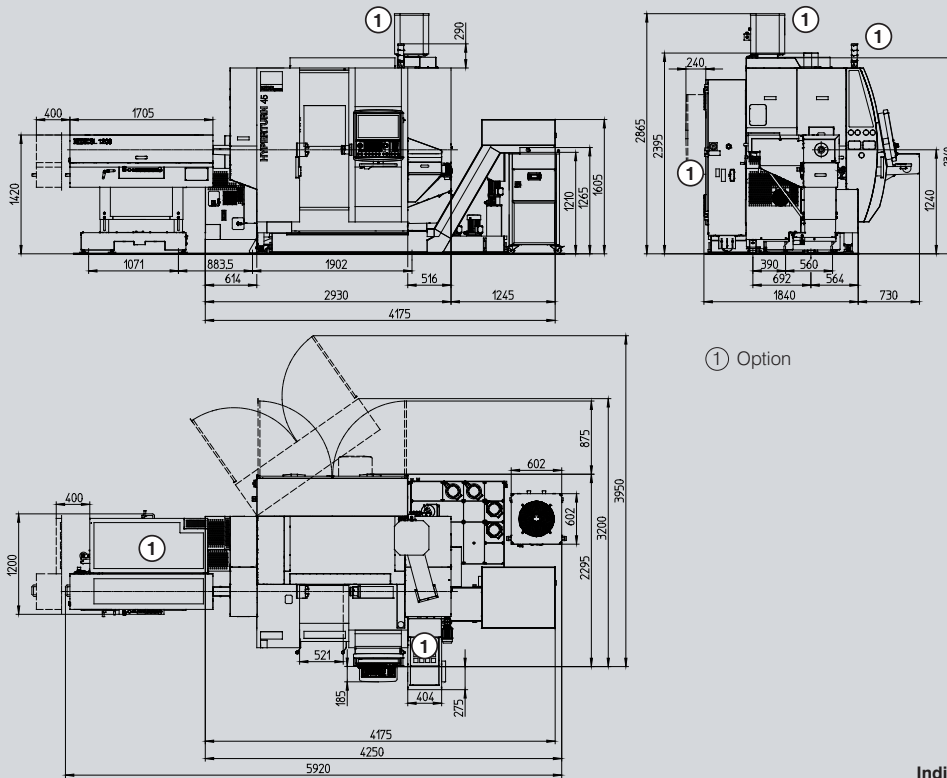

Floor plan HT45-G3 with EMCO SL1200 and paper band filter system

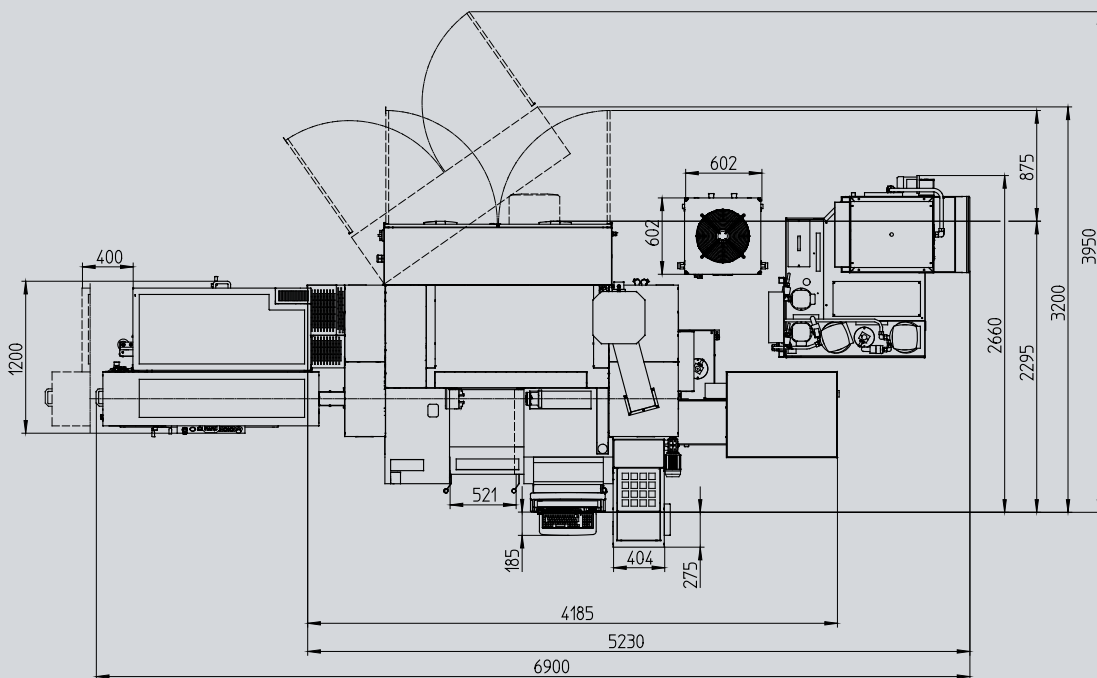

Machine layout EMCO TOP LOAD 8-42/3200

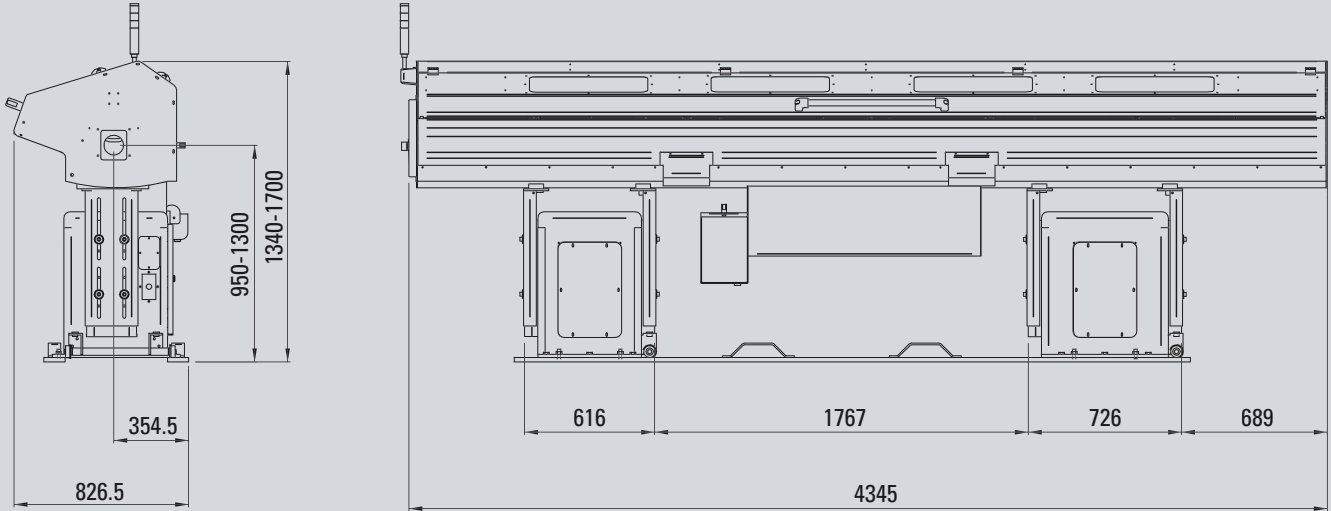

Indications in millimeters

Work area HT45-G3 with 12-station VDI25 turret

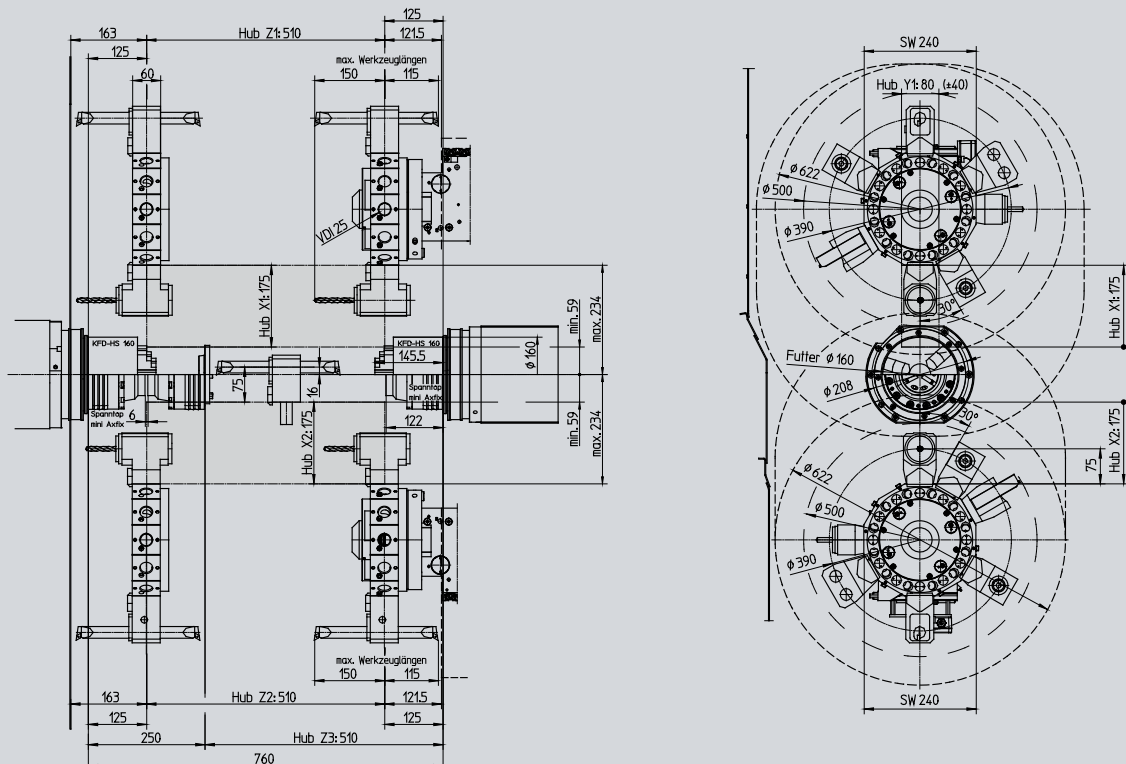

Indications in millimeters

Work area HT45-G3 with 12-station BMT45P turret

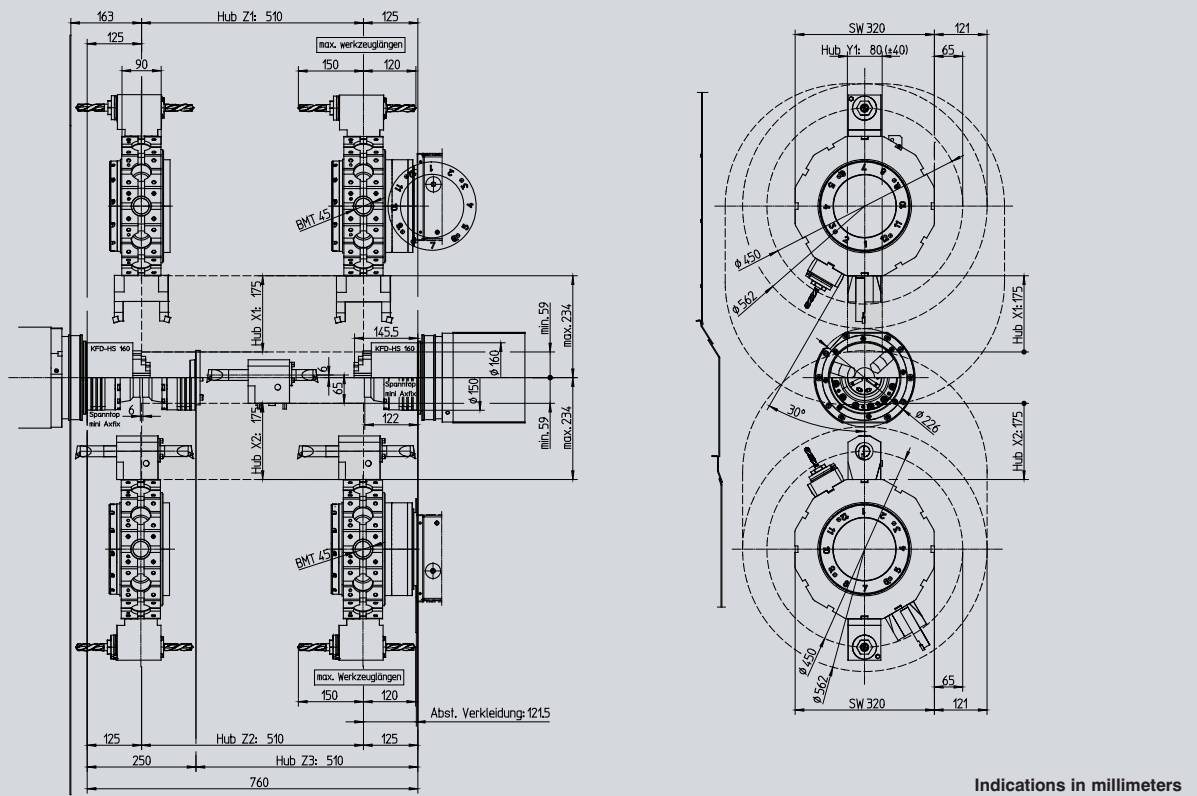

Work area HT45-G3 with 16-station BMT45P turret

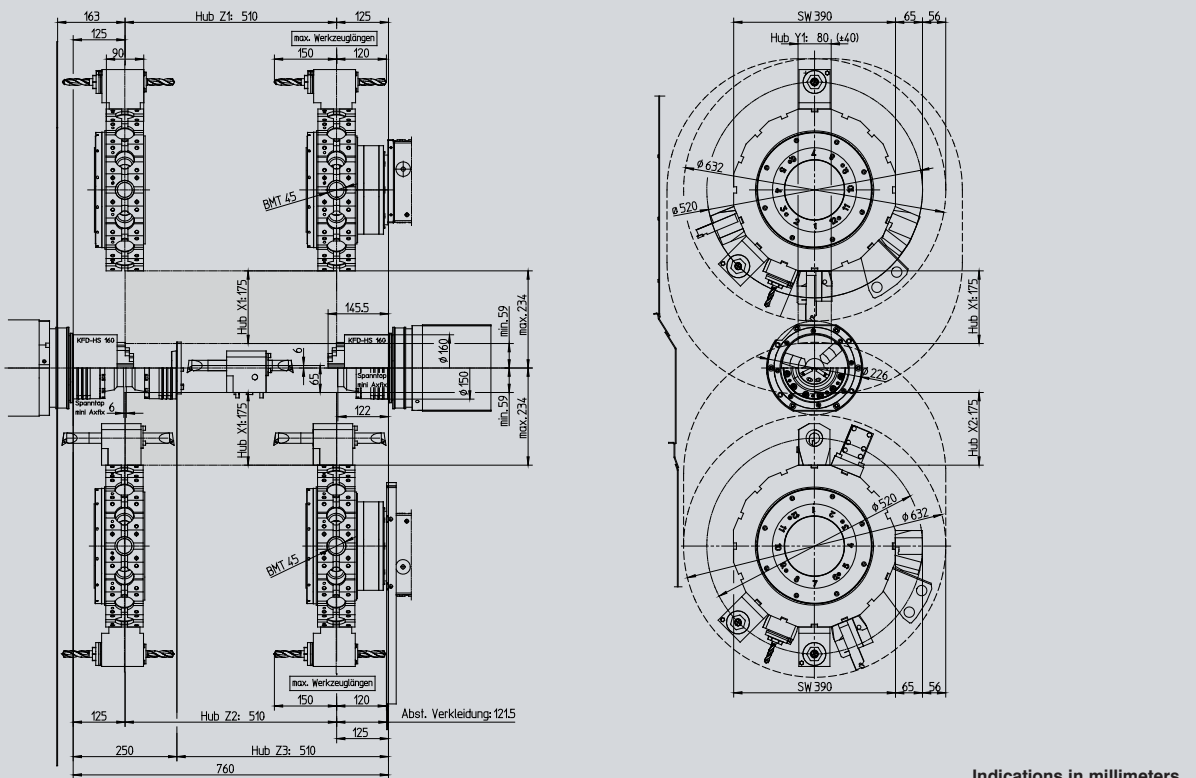

Quality that pays off.

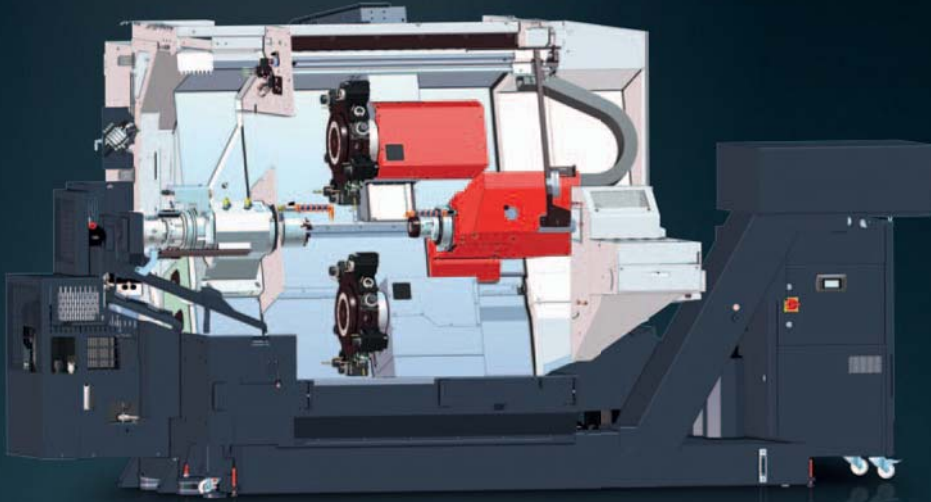

Coolant pumps

Low-maintenance immersion pumps for pressures of up to 25 bar and flow rates of up to 1500 l/min provide optimum conditions for machining and enable reliable chip transportation.



Clamping cylinder / chuck

Hydraulically activated clamping cylinders and chucks guarantee the precise, safe clamping of work pieces. Programmable sensors are used for stroke monitoring. There is no need for time-consuming adjustments of contactless limit switches.



Tool holder

Innovative, fully developed tool holder systems form the basis for cost-effective machining. High changeover accuracy and stability result in short setup and cycle times.



Headstocks

The design and manufacture of headstocks are two of EMCO's core competencies. During engineering, the focus is on precision, robustness, high rigidity, precise rotational characteristics, and a long service life.

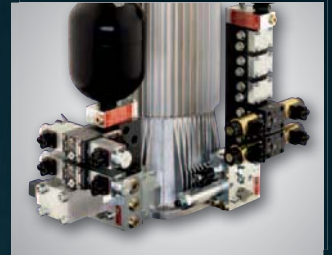

Hydraulic systems

Compact dimensions, quiet operation, and high energy efficiency - just some of the advantages of the hydraulic assemblies used by EMCO. Monitored pressure switches prevent the need for time-consuming manual pressure adjustments.



Machine bases and slides

When matching components, we place great value on high stability, good damping characteristics, and a thermoneutral design. We achieve high stability through a shorter force flow, thermal stability through symmetry, and dampening through the materials and interfaces selected.



Tool turret

Rapid-indexing turrets with adjustable swivel speeds and milling drives represent the current state of the art. The backlash-free milling drive is not only ideal for milling and drilling, but also for rigid tapping, hobbing, and polygonal turning.



Ball screws and roller guides

Highly precise and generously dimensioned guide rails and ball screws with optimal pretensioning form the basis for the machining of precision parts.



Chip conveyor

Slat band conveyors allow for flexible implementation and the safe removal of chips. A monitored overload clutch prevents damage from improper use.

Minimum use of resources for maximum profit.



At EMCO, we take a consistent, responsible approach to the use of resources in machine tools in order to safeguard long-term investments. From the development of our machines through to their construction and manufacture, we place a strong focus on the sensible and sparing use of raw materials and energy. This enables us to achieve parallel savings in two areas:

1. Reduction in the basic power consumption of machine tools, e.g. assemblies are switched on and off as required and the installed connected loads are kept to a minimum.
2. Reduction in variable consumption: This can be seen in the lighter axes, energy recovery system, increased rate of good parts, and the shorter process chain enabled by complete machining.

Through these measures, which are constantly being refined and further optimized, EMCO truly demonstrates that its slogan of "Designed for your Profit" is not just an empty promise: EMCO products help save the environment and provide intelligent customer savings without compromising on quality and flexibility.

[Regenerative drive system]

Kinetic energy is converted into electrical energy and fed back into the grid.
Savings of up to 10%

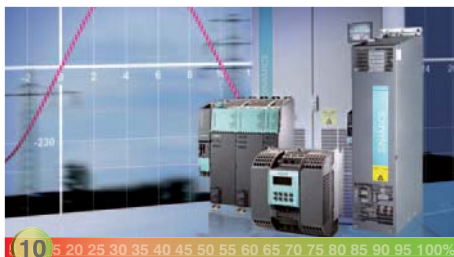

[Compact hydraulics unit with pressure accumulator]

Thanks to its accumulator charging system, the pump only runs when required. If the pressure accumulator is full, the pump switches over to closed loop circulation.
Savings of up to 90%



[Roller guides]

Extremely low friction losses thanks to rolling friction. Highly dynamic performance with minimal lubricant consumption.
Savings of up to 50%



[Structurally optimized mechanics]

FEM analysis is used to optimize the relevant components in terms of their rigidity while simultaneously reducing their weight.
Savings of up to 10%

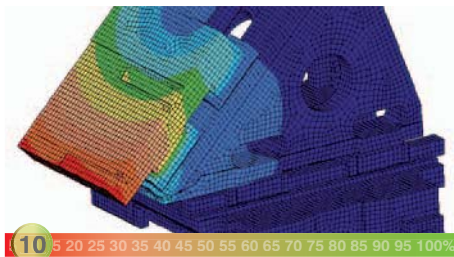

[Highly efficient motors]

The use of energy-efficient motors (IE2) in the coolant preparation area guarantee highly cost-effective operation.
Savings of up to 10%



[Synchronized chip conveyor]

Programmable interval times enable optimal use of the chip conveyor independently of the machining process.
Savings of up to 95%

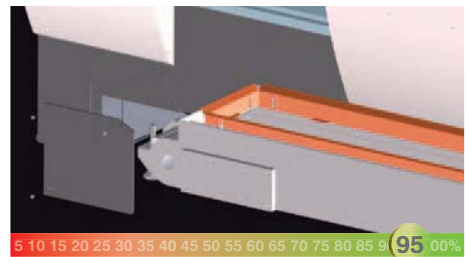

[Intelligent standby concepts]

Reduced consumption by automatically switching off ancillary units and machine space/screen illumination after a defined period of inactivity on the control panel.
Savings of up to 50%



[Virtual machine]

Significant reduction in the setup and running-in times on the machine through the use of highly developed simulation and programming software.
Savings of up to 85%



[Intelligent energy management]

Intuitive data entry screens for activating the individual energy-saving functions.
Savings of up to 70%



HYPERTURN 45 - G3

Technical Data

Working area

Swing over bed	Ø 430 mm
Swing over cross slide	Ø 300 mm
Distance from main spindle to counter spindle	760 mm
Max. turning diameter	Ø 300 mm
Max. part length	480 mm
Max. bar capacity	Ø 45 (51) mm

Travel

Slide travel in X / X2	175 / 175 mm
Slide travel in Z / Z2 / Z3	510 / 510 / 510 mm
Travel in Y	+40 / -40 mm

Main spindle

Speed range	0 – 7000 rpm
Max. torque on the spindle	100 Nm
Spindle nose DIN 55026	A2-5
Spindle bearing (inner diameter at front)	Ø 85 mm
Spindle bore	Ø 53 mm

Counter spindle

Speed range	0 – 7000 rpm
Max. torque on the spindle	100 Nm
Spindle nose DIN 55026	A2-5
Spindle bearing (inner diameter at front)	Ø 85 mm
Spindle bore	Ø 53 mm

C-axes

Resolution of the rotary axis	0.001°
Rapid motion speed	1000 rpm
Spindle indexing (disc brake)	0.01°

Drive power

Main spindle	15 kW
Counter spindle	15 kW

Tool turrets, VDI / BMT

Number of tool positions	2 x 12 / 2 x 12 (16)
Tool holders	VDI25 / BMT45P
Tool cross section for square tools	16 x 16 / 20 x 20 (25 x 25) mm
Shank diameter for boring bars	Ø 25 / Ø 32 (40) mm
Revolver switch time	0.2 / 0.2 sec

Driven tools, VDI / BMT

Speed range	0 – 8000 / 0 – 12000 rpm
Torque	16 / 20 Nm
Drive performance	4 / 8 kW
Number of driven tools	2 x 12 / 2 x 12 (16)

Feed drives

Rapid motion speed X / Y / Z	30 / 15 / 45 m/min
Feed force in the X-axis / Y-axis	4000 N
Feed force in the Z-axes	5000 N
Feed force in the Z-axes, counter spindle	6000 N
Position variation Ps (VDI 3441) X / Y / Z	3 / 3 / 3 µm

Coolant system

Tank volume	300 l
Coolant pumps for the tool turrets	2 x 14 bar
Flushing pumps for the work area	2 x 3.7 bar

Power consumption

Connected load	30 kVA
Supply pressure	6 bar

Dimensions/weight

Height of center above floor	1240 mm
Machine height	2340 mm
Space occupied BxT (not including chip conveyor and coolant)	3055 x 2311 mm
Total weight of machine	5900 kg

Safety devices CE compliant