

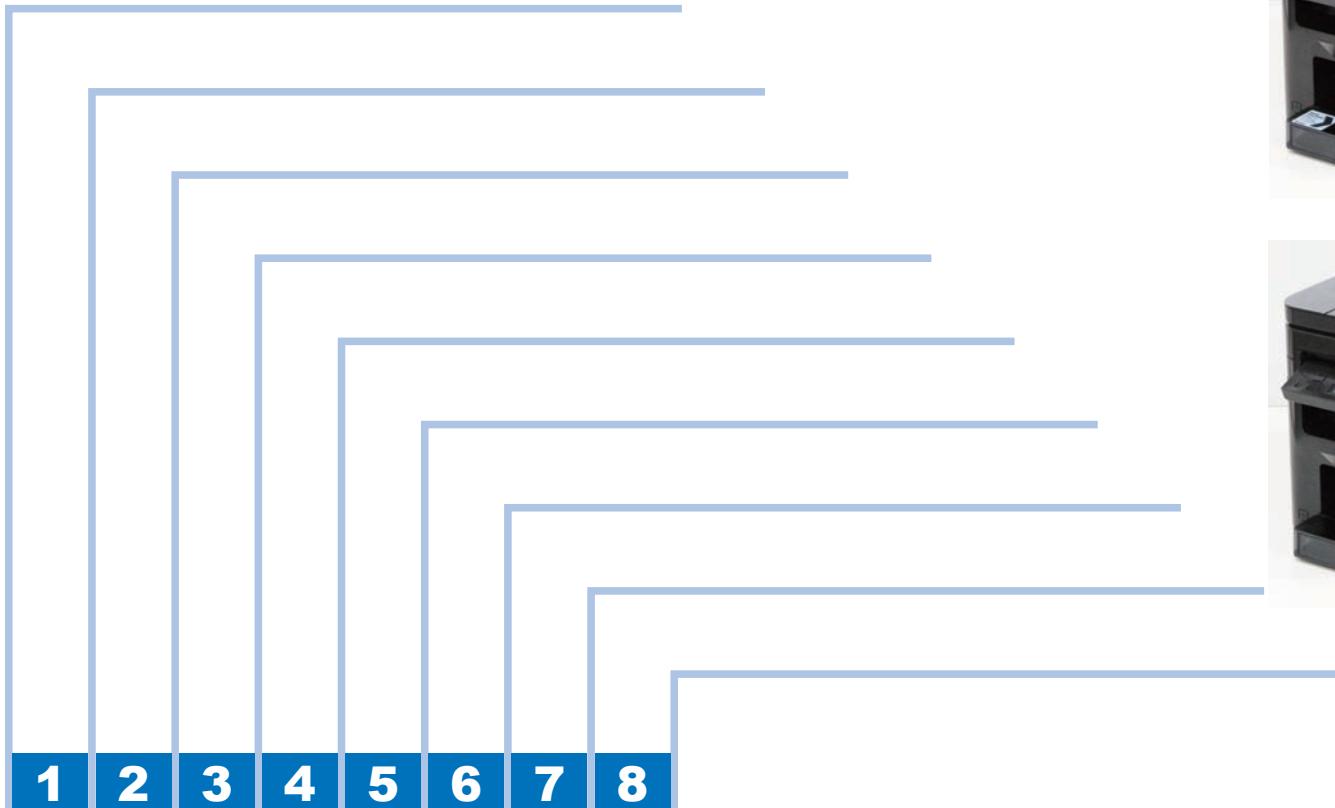

i-SENSYS MF229dw/MF226dn/MF217w/

MF216n/MF212w/MF211 Series

Service Manual Rev.1.0



Application

This manual has been issued by Canon Inc. for qualified persons to learn technical theory, installation, maintenance, and repair of products. This manual covers all localities where the products are sold. For this reason, there may be information in this manual that does not apply to your locality.

Corrections

This manual may contain technical inaccuracies or typographical errors due to improvements or changes in products. When changes occur in applicable products or in the contents of this manual, Canon will release technical information as the need arises. In the event of major changes in the contents of this manual over a long or short period, Canon will issue a new edition of this manual.

The following paragraph does not apply to any countries where such provisions are inconsistent with local law.

Trademarks

The product names and company names used in this manual are the registered trademarks of the individual companies.

Copyright

This manual is copyrighted with all rights reserved. Under the copyright laws, this manual may not be copied, reproduced or translated into another language, in whole or in part, without the consent of Canon Inc.



















Copyright CANON INC. 2014



Caution

Use of this manual should be strictly supervised to avoid disclosure of confidential information.



Explanation of Symbols

The following symbols are used throughout this Service Manual.

Symbols	Explanation	Symbols	Explanation
	Check.		Remove the claw.
	Check visually.		Insert the claw.
	Check a sound.		Push the part.
	Disconnect the connector.		Connect the power cable.
	Connect the connector.		Disconnect the power cable.
	Remove the cable/wire from the cable guide or wire saddle.		Turn on the power.
	Install the cable/wire to the cable guide or wire saddle.		Turn off the power.
	Remove the screw.		Loosen the screw.
	Install the screw.		Tighten the screw.

Symbols	Explanation	Symbols	Explanation
	Cleaning is needed.		Measurement is needed.

The following rules apply throughout this Service Manual:

- Each chapter contains sections explaining the purpose of specific functions and the relationship between electrical and mechanical systems with reference to the timing of operation.
In the diagrams,  represents the path of mechanical drive; where a signal name accompanies the symbol, the arrow  indicates the direction of the electric signal. The expression "turn on the power" means flipping on the power switch, closing the front door, and closing the delivery unit door, which results in supplying the machine with power.
- In the digital circuits, '1' is used to indicate that the voltage level of a given signal is "High", while '0' is used to indicate "Low". (The voltage value, however, differs from circuit to circuit.) In addition, the asterisk (*) as in "DRMD*" indicates that the DRMD signal goes on when '0'.
In practically all cases, the internal mechanisms of a microprocessor cannot be checked in the field. Therefore, the operations of the microprocessors used in the machines are not discussed: they are explained in terms of from sensors to the input of the DC controller PCB and from the output of the DC controller PCB to the loads.

The descriptions in this Service Manual are subject to change without notice for product improvement or other purposes, and major changes will be communicated in the form of Service Information bulletins.

All service persons are expected to have a good understanding of the contents of this Service Manual and all relevant Service Information bulletins and be able to identify and isolate faults in the machine.

Contents

0 Safety Precautions

CDRH Provisions	0-2
Laser Safety	0-2
About Laser Beams	0-2
Handling Laser Scanner Unit	0-2
Toner Safety	0-3
About Toner	0-3
Handling Adhered Toner	0-3
Notes on Handling Lithium Battery	0-3
Notes on Assembly/Disassembly	0-3

1 Product Overview

Product Lineups	1-2
Main Unit	1-2
Options	1-2
Manufacture Sketch Drawing	1-3
Features	1-4
Features	1-4
Product Specifications	1-4
Main Unit Specifications	1-4
Wireless LAN Specifications	1-6
SADF/DADF Specifications	1-6
FAX Specifications(FAX model Only)	1-7
Name of Parts	1-8
External View	1-8
Cross Section	1-11
Control Panel	1-13

2 Technical Overview

Basic Configuration	2-2
Configuration function	2-2
Basic Sequence	2-2
Controller System	2-4
Main Controller	2-4
Engine Controller	2-4
Service Works	2-5
Document Exposure/Feeder System	2-6
Document Exposure System	2-6
Document Feeder System	2-7
Service Works	2-10
Laser Exposure System	2-11
Overview	2-11
Controlling the Laser Activation Timing	2-12
Laser Control	2-13
Laser Scanner Motor Control	2-13
Service Works	2-14
Image Formation System	2-15
Overview/Configuration	2-15
High-Voltage Control	2-19
Toner Cartridge	2-20
Service Works	2-22
Fixing System	2-23
Overview/Configuration	2-23
Various Control Mechanisms	2-24
Other Functions	2-25
Service Works	2-26
Pickup And Feeding System	2-27
Overview	2-27
Detecting Jams	2-28

Reversal Delay Jam	2-30
Service Works	2-33
External And Controls System	2-34
Power Supply	2-34
Service Works	2-35

3 Periodical Services

Periodically Replaced Parts	3-2
Periodically Replaced Parts	3-2
Consumables	3-2
Consumables	3-2
Periodical Service	3-3
Scheduled Servicing	3-3

4 Disassembly/Assembly

Outline	4-3
List of Parts	4-4
External View	4-4
List of Main Unit	4-7
Electrical Components	4-10
Connectors Layout Drawing	4-19
DADF Unit and Reader Unit	4-19
SADF Unit and Reader Unit	4-20
Copyboard Unit and Reader Unit	4-21
Duplex Printer Unit	4-22
Sinplex Printer Unit	4-25
Original Exposure/Feed System (DADF Model)	4-27
Layout Drawing	4-27
Removing the DADF Unit + Reader Unit	4-27
Disconnecting the DADF Unit + Reader Unit	4-30
Removing the DADF Pickup Unit	4-32
Removing the DADF Motor Unit	4-36
Removing the DADF Solenoid Unit	4-38
Removing the DADF Pickup Roller Unit	4-39
Removing the DADF Separation Pad	4-41
Removing the Copyboard Glass (DADF Model)	4-44

Removing the Contact Image Sensor (DADF Model)	4-46
Removing the Flat Bed Motor Unit (DADF Model)	4-48
Original Exposure/Feed System (SADF Model)	4-51
Layout Drawing	4-51
Removing the SADF Unit + Reader Unit	4-51
Disconnecting the SADF Unit and the Reader Unit	4-54
Removing the SADF Upper Cover Unit	4-56
Removing the SADF Pickup Unit	4-60
Removing the SADF Motor	4-61
Removing the SADF Pickup Roller Unit	4-62
Removing the SADF Separation Pad	4-65
Removing the Copyboard Glass (SADF Model)	4-68
Removing the Contact Image Sensor (SADF Model)	4-70
Removing the Flat Bed Motor Unit (SADF Model)	4-72
Original Exposure/Feed System (Copyboard Model)	4-75
Layout Drawing	4-75
Removing the Copyboard Cover	4-75
Removing the Copyboard Cover + Reader Unit	4-76
Removing the Copyboard Glass (Copyboard Model)	4-78
Removing the Contact Image Sensor (Copyboard Model)	4-80
Removing the Flat Bed Motor Unit (Copyboard Model)	4-82
External Cover/Internal System (Duplex Model)	4-85
Layout Drawing	4-85
Removing the Left Cover (Duplex Model)	4-86
Removing the Right Cover (Duplex Model)	4-87
Removing the Front Cover Unit (Duplex Model)	4-89
Removing the Upper Cover Unit (Duplex Model)	4-89
Removing the Duplex Feed Guide Unit. (Duplex Model)	4-91
Controller System (Duplex Model)	4-93
Layout Drawing	4-93
Removing the Control Panel Unit (Duplex Model)	4-93
Removing the Main Motor (Duplex Model)	4-95
Removing the Main Fan (Duplex Model)	4-97
Removing the Edge Left Cooling Fan (Duplex Model)	4-99
Removing the Edge Right Cooling Fan (Duplex Model)	4-101
Removing the Engine Controller PCB (Duplex Model)	4-102

Removing the Main Controller PCB (Duplex Model)-----	4-105
Removing the FAX NCU PCB (Fax Model 120V/230V) (Duplex Model)-----	4-107
Removing the Wirelss LAN PCB (Wifi Model + Duplex Model) ----	4-108
Removing the Paper Leading Edge Sensor PCB (Duplex Model) -	4-108
Removing the Fixing Delivery/Paper Width Sensor PCB (Duplex Model) -----	4-111
Removing the Toner Sensor and Multi Pickup Sensor Unit (Fax Model + Duplex Model)-----	4-114
Removing the Speaker (Fax Model + Duplex Model) -----	4-116
Laser Exposure System (Duplex Model)-----	4-118
Layout Drawing-----	4-118
Removing the Laser Scanner Unit (Duplex Model) -----	4-118
Image Formation System (Duplex Model)-----	4-120
Layout Drawing-----	4-120
Removing the Transfer Roller (Duplex Model) -----	4-120
Fixing System (Duplex Model)-----	4-122
Layout Drawing-----	4-122
Removing the Fixing Assembly (Duplex Model) -----	4-122
Pickup Feed System (Duplex Model)-----	4-127
Layout Drawing-----	4-127
Removing the Pickup Unit (Duplex Model)-----	4-127
Removing the Pickup Tray Unit (Duplex Model) -----	4-132
Removing the Pickup Roller (Duplex Model) -----	4-134
Removing the Separation Pad (Duplex Model) -----	4-135
Removing the Delivery Slave Roller Unit (Duplex Model) -----	4-136
Removing the Pickup Solenoid (Duplex Model)-----	4-137
Removing the Duplex Solenoid (Duplex Model) -----	4-141
External Cover/Internal System (Simplex Model)-----	4-143
Layout Drawing-----	4-143
Removing the Left Cover (Simplex Model)-----	4-144
Removing the Right Cover (Simplex Model)-----	4-145
Removing the Front Cover Unit (Simplex Model)-----	4-147
Removing the Upper Cover (Simplex Model)-----	4-147
Removing the Rear Cover (Simplex Model) -----	4-149
Controller System (Simplex Model) -----	4-151

Layout Drawing-----	4-151
Removing the Control Panel Unit (Simplex Model) -----	4-151
Removing the Main Motor (Simplex Model)-----	4-153
Removing the Engine Controller PCB (Simplex Model)-----	4-155
Removing the Main Controller PCB (Simplex Model) -----	4-159
Removing the FAX NCU PCB (Fax Model 120V/230V + Simplex Model)-----	4-161
Removing the Wireless LAN PCB (Wifi Model + Simplex Model) --	4-161
Removing the Paper Leading Edge Sensor (Simplex Model) -----	4-162
Removing the Fixing Delivery/Paper Width Sensor PCB (Simplex Model)-----	4-164
Removing the Toner Sensor and Multi Pickup Sensor Unit (Fax Model + Simplex Model) -----	4-167
Removing the Speaker (Fax Model + Simplex Model) -----	4-169
Laser Exposure System (Simplex Model) -----	4-171
Layout Drawing-----	4-171
Removing the Laser Scanner Unit (Simplex Model)-----	4-171
Image Formation System (Simplex Model)-----	4-173
Layout Drawing-----	4-173
Removing the Transfer Roller (Simplex Model)-----	4-173
Fixing System (Simplex Model) -----	4-175
Layout Drawing-----	4-175
Removing the Fixing Assembly (Simplex Model)-----	4-175
Pickup Feed System (Simplex Model)-----	4-180
Layout Drawing-----	4-180
Removing the Pickup Unit (Simplex Model)-----	4-180
Removing the Pickup Tray Unit (Simplex Model)-----	4-184
Removing the Pickup Roller (Simplex Model)-----	4-186
Removing the Separation Pad (Simplex Model)-----	4-187
Removing the Delivery Slave Roller Unit (Simplex Model)-----	4-188
Removing the Pickup Solenoid (Simplex Model) -----	4-190

5 Adjustment

Mechanical Adjustment	5-2
Confirming Nip Width	5-2

6 Trouble Shooting

Test Print	6-2
Test Print Function	6-2
Trouble Shooting Items	6-3
Image Faults	6-3
Log Collector	6-8
OutLine	6-8
Version Upgrade	6-10
Overview	6-10
UST	6-10
Preparation	6-10
Downloading System Software	6-11
Upgrading via Internet	6-13

7 Error Codes

Overview	7-2
Error Codes	7-3
Jam Codes	7-4

8 Service Mode

Overview	8-2
Entering Service Mode.	8-2
Service Mode Menu	8-2
COPIER	8-4
DISPLAY	8-4
I/O	8-5
ADJUST	8-5
FUNCTION	8-6
OPTION	8-8
COUNTER	8-9
FEEDER	8-11

ADJUST	8-11
FUNCTION	8-11
FAX	8-12
List of SSSW	8-12
List of MENU	8-14
List of NUM	8-15
List of NCU	8-16
TESTMODE	8-20
SYSTEM	8-20
SCAN	8-20
FAX	8-21
PANEL	8-22
NETWORK	8-23
SSSW	8-23

Appendix

Service Tools	9-2
Solvent/Oil List	9-3
General Circuit Diagram (Duplex Model)	9-4
General Circuit Diagram (Simplex Model)	9-5
General Timing Chart	9-6
List of User Mode	9-7
Network Settings	9-7
Preferences	9-8
Quiet Mode Time	9-9
Common Settings	9-9
Copy Settings	9-9
Fax Settings	9-9
Scan Settings	9-10
Printer Settings	9-10
Adjustment/Maintenance	9-10
System Management Settings	9-10
Backup Data	9-12

Safety Precautions

- CDRH Provisions
- Laser Safety
- Toner Safety
- Notes on Handling
Lithium Battery
- Notes on Assembly/
Disassembly

CDRH Provisions

Food and Drug CDRH (Center for Devices and Radiological Health) under FDA (Food and Drug Administration) enforced provisions of the section for laser and laser products on August 2, 1976. These provisions are applicable to all laser products manufactured or assembled after August 1, 1976 and allow only products certified their compliance with the provisions to market in the US. Each product shall have affixed the applicable label as shown below to follow the labeling requirements prescribed in CDRH provisions.



Note that the wording included in labels is different depending on laser product classifications.

CANON INC.

30-2, SHIMOMARUKO, 3-CHOME, OHTA-KU, TOKYO,
146, JAPAN

MANUFACTURED :

THIS PRODUCT CONFORMS WITH DHHS RADIATION
PERFORMANCE STANDARD 21 CFR CHAPTER I
SUBCHAPTER J.

F-0-1

Laser Safety

About Laser Beams

Laser radiation may be hazardous to human. The laser scanner unit mounted in this device is sealed in the protective housing and the external cover to prevent laser beams from leaking to the environment. As long as the device is operated under normal conditions, users are safely guarded from laser leaks.

Handling Laser Scanner Unit

Before providing service works for the laser scanner unit and its peripherals, ensure to turn off the power of the device.

Any cover with potential dangers of laser beam reflection has affixed the caution label at the position shown in the figure below.

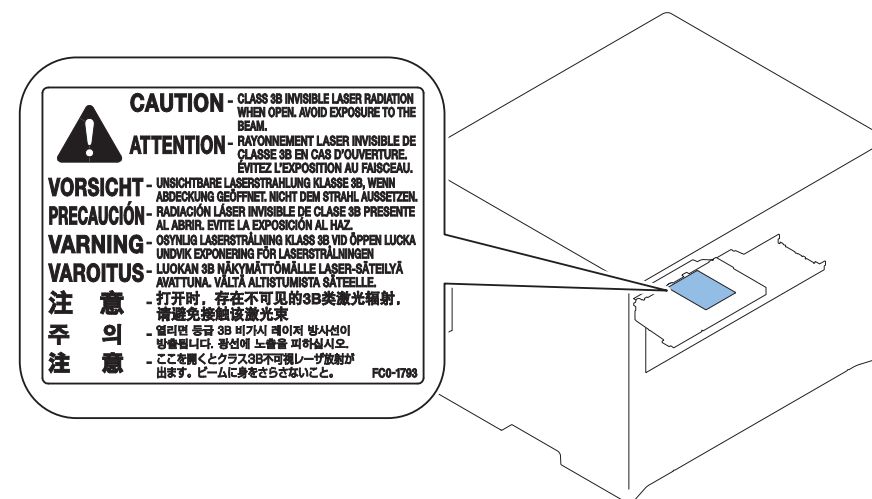

F-0-2

This product is certificated as a Class 1 laser product under IEC60825-1:2007.

But this product is equipped with a class 3B laser.

When you remove interlock and work, you must warn the safety.

Toner Safety

About Toner

Toner is a nontoxic matter composed of plastic, iron and a trace of pigments.



Never throw toner in flames to avoid explosion.

Handling Adhered Toner

- Use dry tissue paper to wipe off toner adhered to skin or clothes and wash in water.
- Never use warm water for cleaning up toner to prevent toner particles from being able to soak into fibers permanently.
- Toner particles are reactive with vinyl polymers. Avoid contacting these materials.

Notes on Handling Lithium Battery



Replacing with wrong battery types may cause explosion.

Follow instructions to dispose used batteries properly.

Notes on Assembly/Disassembly

Follow the items below to assemble/disassemble the device.

1. Disconnect the power plug to avoid any potential dangers during assembling/disassembling works.
2. If not specially instructed, reverse the order of disassembly to reinstall.
3. Ensure to use the right screw type (length, diameter, etc.) at the right position when assembling.
4. To keep electric conduction, binding screws with washers are used to attach the grounding wire and the varistor. Ensure to use the right screw type when assembling.
5. Unless it is specially needed, do not operate the device with some parts removed.
6. Never remove the paint-locked screws when disassembling.







Product Overview

- Product Lineups
- Features
- Product Specifications
- Name of Parts

Product Lineups

Main Unit

Model	i-SENSYS MF229dw	i-SENSYS MF226dn	i-SENSYS MF217w	i-SENSYS MF216n	i-SENSYS MF212w	i-SENSYS MF211
Config	4in1DADF+WN	4in1SADF+N	4in1SADF+WN	4in1SADF+N	3in1Pla+WN	3in1Pla
Design						
ADF	DADF F-1-1	SADF F-1-2	SADF	SADF F-1-3	PLATEN	PLATEN
Engine	2-Sided	2-Sided	1-Sided	1-Sided	1-Sided	1-Sided
LAN port	Yes	Yes	Yes	Yes	Yes	
Wireless LAN	Yes		Yes		Yes	
FAX	Yes	Yes	Yes	Yes		

T-1-1

Options

- Non

Manufacture Sketch Drawing

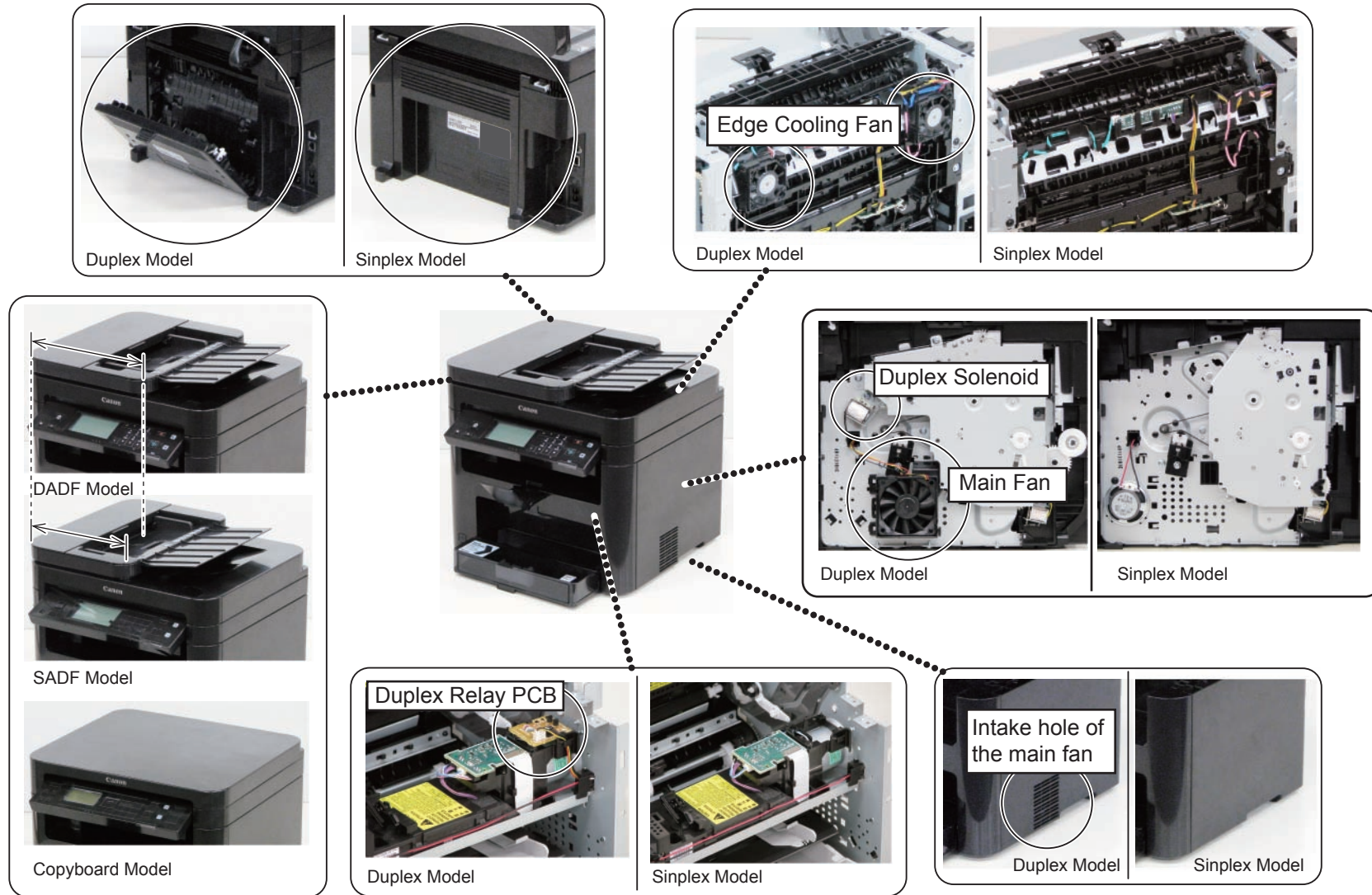

F-1-5

Features

Features

1. Small-size, high-speed monochrome printer
This equipment has a compact body that realizes high-speed print of 27 ppm (A4) / 26 ppm (LTR).
2. Automatic duplex print
Automatic two-sided printing is available with standard equipped duplex unit.
3. Reduction in standby time and energy consumption
This equipment employs on-demand fixing where the heater activates only during printing, resulting in a reduction in standby time and energy consumption on this mode.
4. Realization of noise reduction and stable image quality
This equipment employs a belt drive method for transmitting the drive of the main motor. This enables lower noise and more stable image quality compared to the conventional gear drive method. (See NOTE)
5. Improved Usability
In this equipment maintenance (jam removal, replacing the cartridge) can be performed by accessing one point of the delivery tray.

Note:

Changing the drive method from gear to belt reduces uneven pitch due to varied rotation speed of the photosensitive drum, which realizes stable image quality.

Product Specifications

Main Unit Specifications

Copyboard	Fixed	
Device Installation	Personal Desktop	
Light source	LED (RGB)	
Image scanning	CIS (color)	
Photoreceptor	OPC drum (φ24)	
Light exposure method	Laser beam exposure (semiconductor laser)	
Charging method	Roller charging	
Developing method	Toner projection developing method	
Transfer method	Direct transfer to the transfer member	
Separation method	Curvature separation	
Paper feed method	Pickup Tray : Semilunar-shaped Pickup Roller + Pad separation method (pressure release mechanism is not available) Multi-purpose Tray : Semilunar-shaped Pickup Roller + Pad separation method (pressure release mechanism is not available)	
Paper delivery method	Face-down	
Drum cleaning method	Cleaning blade	
Fixing method	SURF fixing method with the Ceramic Heater	
Toner supply method	All-in-one cartridge with drum	
Toner level sensor	Fax model: Yes (magnetic sensor)	
Document types	Sheets, Book, Height of document : 20 mm, Weight: up to 2 Kg	
Maximum document size	Fixation : to A4 ADF : to LGL	
Image size magnification	100% Direct, 400% Max, 200%, 129% STMT->LTR, 78% LGL->LTR, 64% LTR->STMT, 50%, 25% Min	
Zoom	Zoom : 25 to 400 % (1 % increment)	
Reading resolution	Text/photo : 300 dpi x 300 dpi (default) Text/photo : 600 dpi x 600 dpi Text : 600 dpi x 600 dpi Photo : 600 dpi x 600 dpi	
Print resolution	1,200 dpi equivalent x 1,200 dpi equivalent	
Warm-up Time	13.5 seconds or less	
First print time	6.0 seconds or less	
First copy time	• Platen glass: 9 seconds or less • Feeder: 14 seconds or less	
Print Speed	Simplex Print	Duplex Model: 28 ppm(LTR), 27 ppm(A4) Simplex Model: 24 ppm(LTR), 23 ppm(A4)
	Duplex Print	Duplex Model: 16 cpm(LTR), 15 cpm(A4) Simplex Model: Non Duplex Print

Copy speed	Simplex Print	Duplex Model: 28 ppm(LTR), 27 ppm(A4) Simplex Model: 24 ppm(LTR), 23 ppm(A4)
	Duplex Print	Duplex Model: 16 cpm(LTR), 15 cpm(A4) Simplex Model: Non Duplex Print
Available paper size in Paper Cassette	Fixed size : A4 *1 , B5, A5, Legal *1, Letter *1 , Statement, Executive *1, Officio *1, B-officio *1, M-officio *1, Government - Letter, Government - Legal, Foolscap *1, Australian-foolscap, Indian-Legal *1, Envelope COM10, Envelope Monarch *2, Envelope C5, Envelope DL, Index Card *2	
	Custom paper size : • Envelope: COM10 / Monarch / C5 / DL • Width: 76.2 to 216.0 mm • Length: 148.0 to 356.0 mm	
Available paper size in multi-purpose tray	Fixed size : A4 *1 , B5, A5, Legal *1, Letter *1 , Statement, Executive *1, Officio *1, B-officio *1, M-officio *1, Government - Letter, Government - Legal, Foolscap *1, Australian-foolscap, Indian-Legal *1, Envelope COM10, Envelope Monarch *2, Envelope C5, Envelope DL, Index Card *2	
	Custom paper size : • Envelope: COM10 / Monarch / C5 / DL • Width: 76.2 to 216.0 mm • Length: 148.0 to 356.0 mm	
Paper types for Paper Cassette	Plain paper*3 (60 to 90 g/m ² (16 to 24 lb Bond)), Heavy paper*4 (90 to 163 g/m ² (24 to 60 lb Bond)), Recycled paper*3 (60 to 90 g/m ² (16 to 24 lb Bond)), Color paper*3 (60 to 90 g/m ² (16 to 24 lb Bond)), Bond paper*5 (60 to 163 g/m ² (16 lb Bond to 60 lb Cover)), Transparency, Label, Envelope	
Multi-Purpose Tray	Plain paper*3 (60 to 90 g/m ² (16 to 24 lb Bond)), Heavy paper*4 (90 to 163 g/m ² (24 to 60 lb Bond)), Recycled paper*3 (60 to 90 g/m ² (16 to 24 lb Bond)), Color paper*3 (60 to 90 g/m ² (16 to 24 lb Bond)), Bond paper*5 (60 to 163 g/m ² (16 lb Bond to 60 lb Cover)), Transparency, Label, Envelope	
Stack capacity of Paper Cassette	About 250 sheets (60 to 80 g/m ²)	
Stack capacity of Multi-purpose Tray	1 sheet	
Output tray stacking capacity	About 100 sheets (60 to 80 g/m ²)	
Allowable environmental temperature	10 - 30 deg C(50 to 86°F)	
Allowable humidity	20 - 80 %	
Duplex method	Yes	
Interface	• 100BASE-TX • 10BASE-T • Hi-Speed USB • IEEE 802.11b/g/n (Infrastructure mode)	
Hard Disk	Standard : none, Option : none	

Power Supply	110 to 127 V, 50/60 Hz 220 to 240 V, 50/60 Hz (Power requirements differ depending on the country in which you purchased the product.)
Power Consumption	<Maximum> • Duplex Model : 1,220 W • Simplex Model : 1,190 W <Average consumption during standby mode> • Duplex Model : Approx. 5.8 W • Simplex Model : Approx. 5.4 W <Average consumption during sleep mode> • Duplex Model : • Wired Connections : Approx. 1.7 W • Wireless Connections : Approx. 2.3 W • Simplex Model : • Wired Connections : Approx. 1.6 W • Wireless Connections : Approx. 2.0 W <When the power switch is turned OFF> • 0.5 W or less
Dimensions (W x L x H)	• DADF model: 390 mm x 378 mm x 360 mm(15" 3/8 x 14" 7/8 x 14" 1/4) • SADF model: 390 mm x 371 mm x 360 mm (15" 3/8 x 14" 5/8 x 14" 1/4) • PLATEN model: 390 mm x 371 mm x 312 mm(15 3/8" x 14 5/8" x 12 1/4")
Weight (The value indicates the mass of the main unit including toner cartridges.)	• MF229dw: Approx. 13.7 kg(30.2 lb) • MF227dw: Approx. 12.8 kg(28.2 lb) • MF226dn: Approx. 12.8 kg(28.2 lb) • MF216n: Approx. 12.1 kg(26.7 lb) • MF212w: Approx. 10.8 kg(23.8 lb)

T-1-2

*1 : Only in Duplex Model, automatic 2-sided printing is available without replacing paper.

*2 : You can load Envelope Monarch and Index Card only in the manual feed slot

*3 : Only in Duplex Model, automatic 2-sided printing is available without replacing paper.

*4 : Only in Duplex Model, automatic 2-sided printing is available for heavy paper 1 (90 to 120 g/m²).

*5 : Only in Duplex Model, automatic 2-sided printing is available for bond paper 1 (60 to 90 g/m²) and bond paper 2 (90 to 120 g/m²).

Wireless LAN Specifications

Standard	IEEE 802.11g, IEEE 802.11b, IEEE 802.11n
Frequency Range	2,412 to 2,462 MHz
Data Transmission Rate	<ul style="list-style-type: none"> IEEE 802.11g 6/9/12/18/24/36/48/54 Mbps IEEE 802.11b 1/2/5.5/11 Mbps IEEE 802.11n SGI Invalidated 20 MHz: 6.5/13/19.5/26/39/52/58.5/65 Mbps SGI Validated 20 MHz: 7.2/14.4/21.7/28.9/43.3/57.8/72.2 Mbps
Communication Mode	Infrastructure Mode
Security	WEP 64/128 bit, WPA-PSK (TKIP/AES), WPA2-PSK (AES), 802.1x (LEAP, EAP-FAST, PEAP, EAP-TLS, EAP-TTLS)
Connection Method	WPS (Wi-Fi Protected Setup), Manual setup

T-1-3

* WPS (Wi-Fi Protected Setup), Connection can be established by manually setting values.

SADF/DADF Specifications

Document pickup method	Auto pickup method	
Document setting direction	face-up method	
Document type	Sheet document	
Document size	DADF	Size: A4R/B5R/A5/B6 (landscape)/LGL/LTRR 2-sided: A4R/B5R/A5/LTRR/LGL/B6 (landscape only) • Feed direction : 127 mm to 356 mm • Width direction : 140 mm to 216 mm
	SADF	Size: A4R/B5R/A5/B6 (landscape)/LGL/LTRR • Feed direction : 105 mm to 356 mm • Width direction : 148 mm to 216 mm
Document processing mode	SADF	1-sided document -> 1-sided copy, 1-sided document -> 2-sided copy
	DADF	1-sided document -> 1-sided copy, 1-sided document -> 2-sided copy, 2-sided document -> 1-sided copy, 2-sided document -> 2-sided copy
Document weight	Continuous feed	1-sided : 50 to 105 g/m ²
	Continuous reading	2-sided : 60 to 105 g/m ²
Document stack capacity *	DADF	S size: 50 Sheets/L size : 10 Sheets
	SADF	S size: 35 Sheets/L size : 10 Sheets
Document setting position	Center reference	
Document reading method	Stream reading	
Mixed paper reading	None	
Document size sensor	None	
Document AE sensor	None	
Stamp function	None	
Document feed speed (at reading)	100 %	DADF: 129.34 mm/s SADF: 113.38 mm/s
Document processing speed (At A4, LTR)	Mono	<ul style="list-style-type: none"> 1-sided constant speed, DADF 22 ipm (sheets/min) 1-sided constant speed, SADF 20 ipm (sheets/min) 2-sided constant speed, DADF 8 ipm (sheets/min)
	Color	<ul style="list-style-type: none"> 1-sided constant speed, DADF 15 ipm (sheets/min) 1-sided constant speed, SADF 15 ipm (sheets/min) 2-sided constant speed, DADF 5 ipm (sheets/min)

T-1-4

*:

Ssize: A4R, B5R, A5R, B6, LTRR, STMTR, 16KR

L size: LGL

FAX Specifications(FAX model Only)

Line Used	Public Switched Telephone Network (PSTN)*1
Communication Mode	Super G3, G3
Compression Method	MH, MR, MMR
Modem Speed	Super G3: 33.6 Kbps, G3: 14.4 Kbps Automatic Fallback
Transmission Speed	Approx. 3 seconds per page*2 (ECM-MMR, transmitting from the memory at 33.6 Kbps)
Sending from Memory/ Receiving in Memory	Maximum approx. 256 pages*2 (Total pages of transmission/reception) (Maximum number of fax jobs that can be sent from the memory: 10 jobs/ Maximum number of fax jobs that can be received into the memory: 90 jobs)
Fax Resolution	<ul style="list-style-type: none"> • Normal: 200 x 100 dpi • Fine: 200 x 200 dpi • Photo: 200 x 200 dpi • Superfine: 200 x 400 dpi
Dialing	<ul style="list-style-type: none"> • One-touch keys (4 destinations) • Coded dialing (100 destinations) • Group dialing (103 groups) • Address Book dialing • Regular dialing (with numeric keys) • Automatic redialing • Manual redialing • Sequential broadcast (114 destinations)
Receiving	<ul style="list-style-type: none"> • Automatic reception • Remote reception by telephone (Default ID: 25)
Reports	<ul style="list-style-type: none"> • Send Results • Transmission management report (By default, auto output every 40 destinations) • RX Results
Telephone Type	External telephone/External telephone with the built-in answer function/Data modem

T-1-5

*1 The Public Switched Telephone Network (PSTN) currently supports 28.8 Kbps modem speed or lower. Note that speeds can vary depending on the telephone line conditions.

*2 Based on ITU-T (ITU Telecommunication Standardization Sector) Standard Chart No. 1, MMR standard mode.

Name of Parts

External View

DADF Unit and Reader Unit

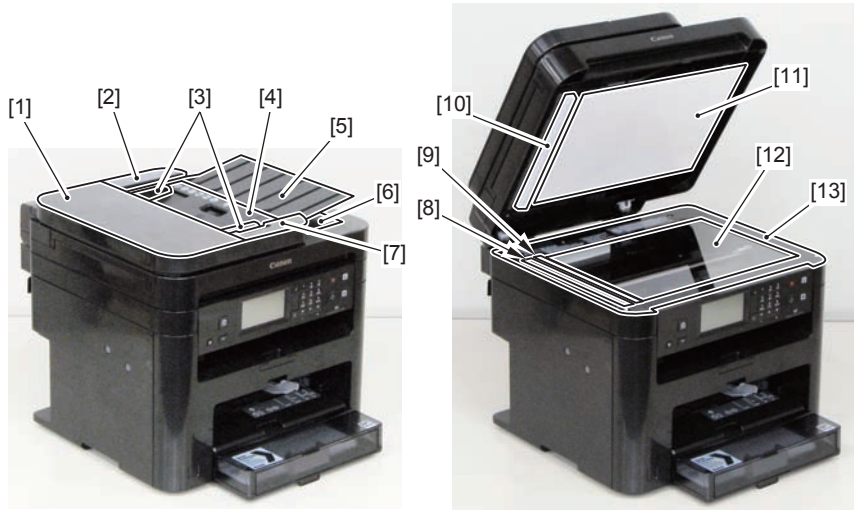

F-1-6

No.	Name	Remarks
[1]	DADF Upper Cover	-
[2]	DADF Rear Cover	-
[3]	Side Guide Plate	-
[4]	Original Feed Tray	-
[5]	Original Feed Auxiliary Tray	-
[6]	Original Delivery Tray	-
[7]	DADF Front Cover	-
[8]	Document Reading Glass	-
[9]	Copyboard Guide Holder	-
[10]	White Guide Plate	-
[11]	White Plate	-
[12]	Copyboard Glass	-
[13]	Copyboard Upper Cover	-

T-1-6

SADF Unit and Reader Unit

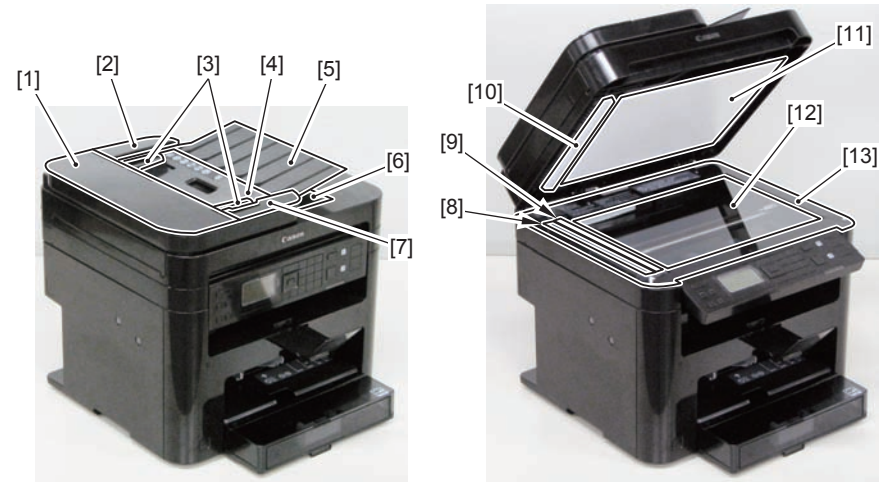

F-1-7

No.	Name	Remarks
[1]	SADF Upper Cover	-
[2]	SADF Rear Cover	-
[3]	Side Guide Plate	-
[4]	Original Feed Tray	-
[5]	Original Feed Auxiliary Tray	-
[6]	Original Delivery Tray	-
[7]	SADF Front Cover	-
[8]	Document Reading Glass	-
[9]	Copyboard Guide Holder	-
[10]	White Guide Plate	-
[11]	White Plate	-
[12]	Copyboard Glass	-
[13]	Copyboard Upper Cover	-

T-1-7

■ Copyboard Unit and Reader Unit



F-1-8

No.	Name	Remarks
[1]	Copyboard Upper Cover	-
[2]	Copyboard Guide Holder	-
[3]	White Plate	-
[4]	Copyboard Glass	-
[5]	Copyboard Upper Cover	-

T-1-8

■ Printer Unit (Duplex)

● Front Side (Duplex)

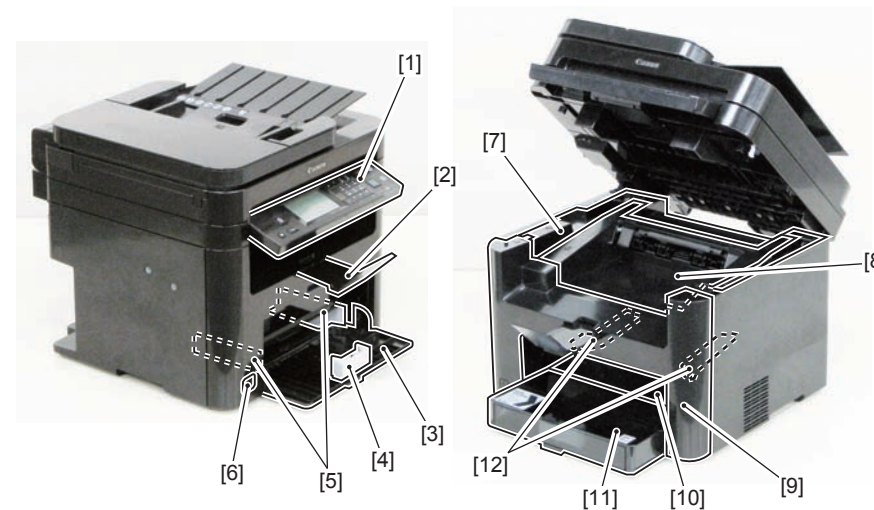

F-1-9

No.	Name	Remarks
[1]	Control Panel Unit	-
[2]	Delivery Auxiliary Tray	-
[3]	Pickup Tray	-
[4]	Trailing Edge Paper Guides	-
[5]	Pickup Tray Side Guide Plate	-
[6]	Power Switch	-
[7]	Upper Cover	-
[8]	Delivery Tray	-
[9]	Front Cover Unit	-
[10]	Multi-Purpose Tray	-
[11]	Tray Cover	-
[12]	Multi-Purpose Tray Side Guide Plate	-

T-1-9

● Rear Side (Duplex)

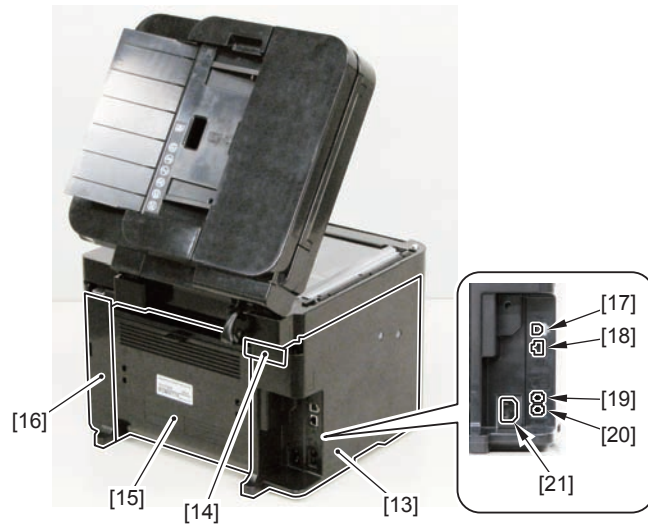

F-1-10

No.	Name	Remarks
[13]	Left Cover	-
[14]	Hinge Face Cover	-
[15]	Duplex Feed Guide Unit	-
[16]	Right Cover	-
[17]	USB Device Port	-
[18]	LAN Port	Model with NET
[19]	External Device Jack	Model with FAX
[20]	Telephone Line Jack	Model with FAX
[21]	Power Supply Cord Slot	-

T-1-10

■ Printer Unit (Sinplex)

● Front Side (Sinplex)

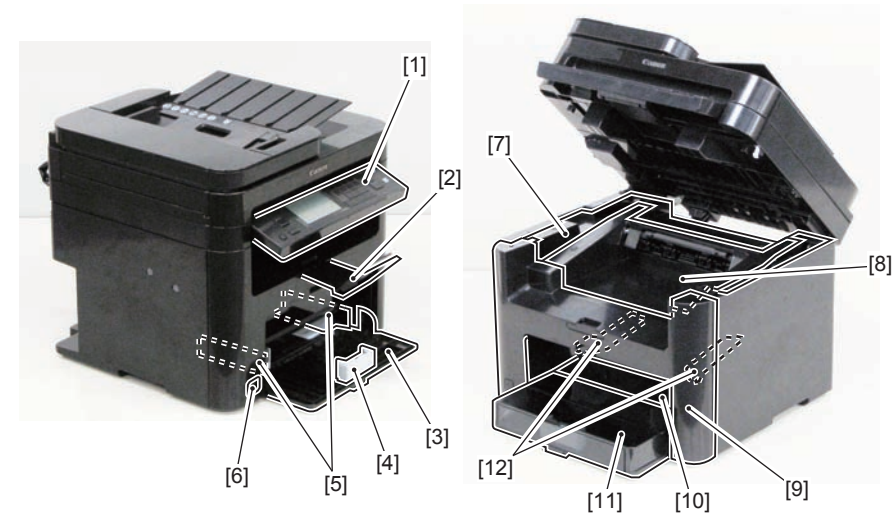

F-1-11

No.	Name	Remarks
[1]	Control Panel Unit	-
[2]	Delivery Auxiliary Tray	-
[3]	Pickup Tray	-
[4]	Trailing Edge Paper Guides	-
[5]	Pickup Tray Side Guide Plate	-
[6]	Power Switch	-
[7]	Upper Cover	-
[8]	Delivery Tray	-
[9]	Front Cover Unit	-
[10]	Multi-Purpose Tray	-
[11]	Tray Cover	-
[12]	Multi-Purpose Tray Side Guide Plate	-

T-1-11

● Rear Side (Simplex)

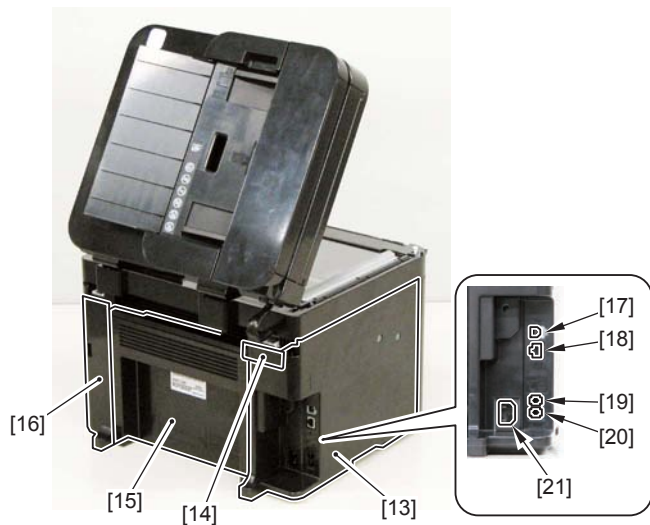

F-1-12

No.	Name	Remarks
[13]	Left Cover	-
[14]	Hinge Face Cover	-
[15]	Rear Cover	-
[16]	Right Cover	-
[17]	USB Device Port	-
[18]	LAN Port	Model with NET
[19]	External Device Jack	Model with FAX
[20]	Telephone Line Jack	Model with FAX
[21]	Power Supply Cord Slot	-

T-1-12

● Cross Section

■ DADF

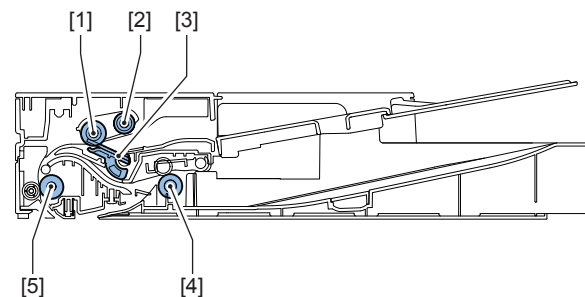

F-1-13

No.	Name
[1]	DADF Pickup Roller
[2]	DADF Separation Roller
[3]	DADF Separation Pad
[4]	DADF Delivery Roller
[5]	DADF Feed ROLLER

T-1-13

■ SADF

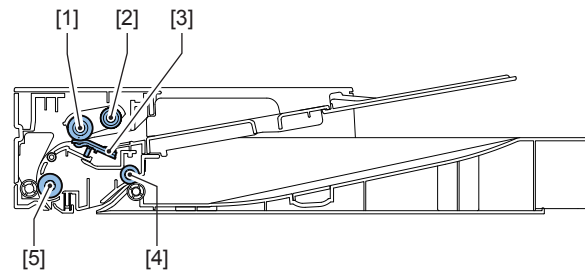

F-1-14

No.	Name
[1]	SADF Pickup Roller
[2]	SADF Separation Roller
[3]	SADF Separation Pad
[4]	SADF Delivery Roller
[5]	SADF Feed ROLLER

T-1-14

Reader

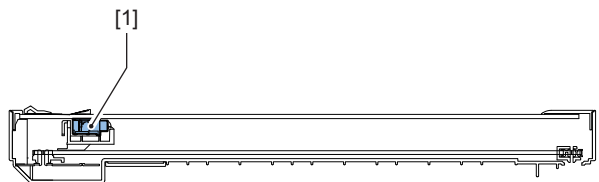

F-1-15

No.	Name
[1]	Contact Sensor

T-1-15

Printer(Duplex Model)

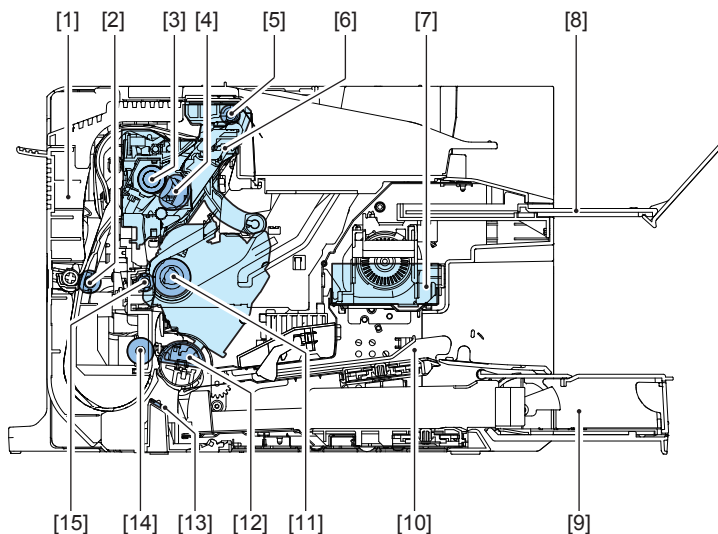

F-1-16

No.	Name	No.	Name
[1]	Duplex Feed Unit	[9]	Pickup Tray
[2]	Duplex Feed Roller	[10]	Multi-Purpose Tray
[3]	Fixing Pressure Roller	[11]	Photosensitive Drum
[4]	Fixing Film Unit	[12]	Pickup Roller
[5]	Delivery Roller	[13]	Separation Pad
[6]	Fixing Assembly	[14]	Feed Roller
[7]	Laser Scanner Unit	[15]	Transfer Roller
[8]	Delivery Auxiliary Tray		

T-1-16

Printer(Sinplex Model)

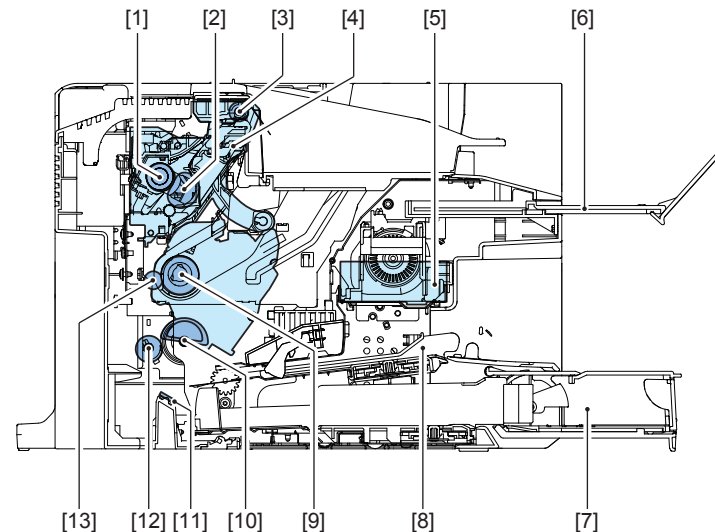

F-1-17

No.	Name	No.	Name
[1]	Fixing Pressure Roller	[8]	Multi-Purpose Tray
[2]	Fixing Film Unit	[9]	Photosensitive Drum
[3]	Delivery Roller	[10]	Pickup Roller
[4]	Fixing Assembly	[11]	Separation Pad
[5]	Laser Scanner Unit	[12]	Feed Roller
[6]	Delivery Auxiliary Tray	[13]	Transfer Roller
[7]	Pickup Tray		

T-1-17

Control Panel

Touch Panel

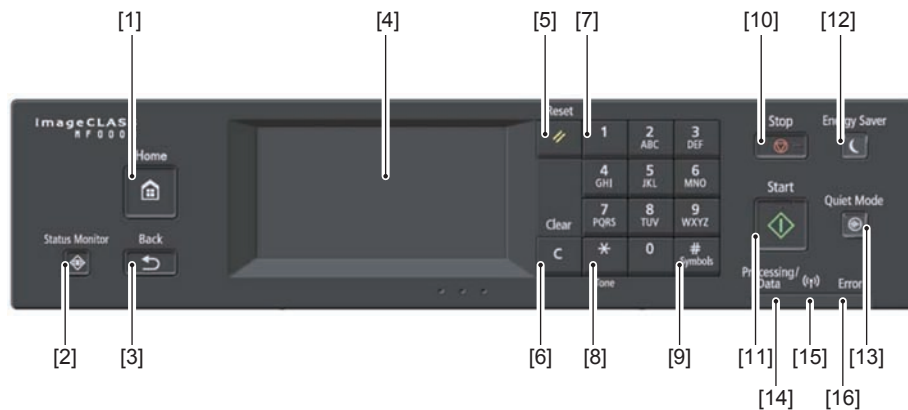

F-1-18

No.	Key/LED Name	Function
[12]	[Energy Saver] key	Press to put the machine into sleep mode. The key lights up green when the machine is in sleep mode. Press the key again to exit sleep mode.
[13]	[Quiet Mode] key	Press to put the machine into quiet mode. While in quiet mode this key is lit in green. Press the key again to exit quiet mode.
[14]	[Processing/Data] indicator	Blinks while operations such as sending or printing are being performed. Lights up when there are documents waiting to be processed.
[15]	Wi-Fi indicator	Lights up when the machine is connected to wireless LAN.
[16]	[Error] indicator	Blinks or lights up when an error such as a paper jam occurs

T-1-18

No.	Key/LED Name	Function
[1]	[HOME] key	Press to display the <Home> Screen.
[2]	[Status Monitor] key	Press to check the status of printing or faxing, to view the usage history, or to view the network settings such as the IP address of the machine. You can also check the status of the machine, such as the remaining amounts of paper and toner, or whether any errors occurred.
[3]	[Back] key	Press to return to the previous screen. If you press this key when specifying settings, for example, the settings are not applied and the display returns to the previous screen.
[4]	Touch Panel	You can view the progress of copy, fax, and other jobs and error statuses. The display is a touch panel, allowing you to operate the screen by touch to specify settings.
[5]	[Reset] key	Press to cancel the settings and restore the previously specified settings.
[6]	[Clear] key	Press to delete the entered numbers and text.
[7]	Numeric keys ([0]-[9] keys)	Press to enter numbers and text.
[8]	[Stop] key	Press to cancel copying, faxing, and other operations.
[9]	[Symbols] key ([#] key)	Press to enter symbols such as "@" or "/".
[10]	[Stop] key	Press to cancel copying, faxing, and other operations.
[11]	[Start] key	Press to scan or copy documents.

LCD Panel

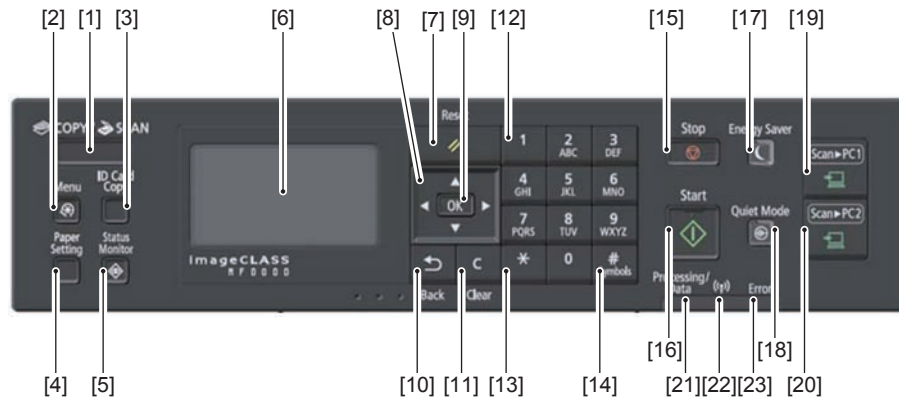

F-1-19

No.	Key/LED Name	Function
[1]	[COPY/SCAN] key	Press to switch the mode to copy or scan.
[2]	[Menu] key	Press to start specifying many of the settings for the machine, such as <Timer Settings> or <Preferences>.
[3]	[ID Card Copy] key	Press to enter a mode for copying the front and back sides of a driver's license or other ID card onto the same side of a page at actual size.
[4]	[Paper Setting] key	Press to select the paper you want to use, or to set the size and type of paper loaded in the paper source.
[5]	[Status Monitor] key	Press to check the status of printing or copy to view the usage history. You can also check the status of the machine, such as the remaining amounts of paper and toner, or whether any errors occurred.
[6]	Display	Displays the operation and status screens for copying and other functions, as well as the status of the machine and error information. Also, view the screen when specifying the settings of the machine.
[7]	[Reset] key	Press to cancel the settings and restore the previously specified settings.

No.	Key/LED Name	Function
[8]	[UP]/[Down]/[Left]/[Right] key	<p>[Left] key</p> <ul style="list-style-type: none"> When specifying settings, press to return to the previous screen. When entering text, press to move the cursor to the left. Press to decrease a setting value such as density for scanning, copying, etc. <p>[Right] key</p> <ul style="list-style-type: none"> When specifying settings, press to proceed to the next screen. When entering text, press to move the cursor to the right. Press to increase the sound volume or a setting value such as density for scanning, copying, etc. <p>[UP] key</p> <ul style="list-style-type: none"> When specifying settings, press to select the item above the currently selected item. When changing setting values, press to increase a value. <p>[Down] key</p> <ul style="list-style-type: none"> When specifying settings, press to select the item below the currently selected item. When changing setting values, press to decrease a value.
[9]	[OK] key	Press to apply settings or specified details.
[10]	[Back] key	Press to return to the previous screen. If you press this key when specifying settings, for example, the settings are not applied and the display returns to the previous screen.
[11]	[Clear] key	Press to delete the entered numbers and text.
[12]	Numeric keys ([0]-[9] keys)	Press to enter numbers and text.
[13]	[Tone] Key ([*] key)	Press to switch the type of text that is entered.
[14]	[Symbols] Key [#] key	Press to enter symbols such as "@" or "/".
[15]	[Stop] key	Press to cancel copying, scanning, and other operations.
[16]	[Start] key	Press to scan or copy documents.
[17]	[Energy Saver] key	Press to put the machine into sleep mode. The key lights up green when the machine is in sleep mode. Press the key again to exit sleep mode.
[18]	[Quiet Mode] key	Press to put the machine into quiet mode. While in quiet mode this key is lit in green. Press the key again to exit quiet mode.
[19]	[Scan -> PC1] Key	Press to send the scanned documents to the registered computer for each key.
[20]	[Scan -> PC2] Key	Press to send the scanned documents to the registered computer for each key.
	[Paper Save Copy] Key	2in1 Simplex -> Duplex, 4in1 Simplex -> Duplex, 2in1 Simplex -> Simplex, 4in1 Simplex -> When I set Simplex, I push it
[21]	[Processing/Data] indicator	Blinks while operations such as sending or printing are being performed. Lights up when there are documents waiting to be processed.
[22]	Wi-Fi indicator	Lights up when the machine is connected to wireless LAN.
[23]	[Error] indicator	Blinks or lights up when an error such as a paper jam occurs

T-1-19

2

Technical Overview

- Basic Configuration
- Controller System
- Document Exposure/Feeder System
- Laser Exposure System
- Image Formation System
- Fixing System
- Pickup And Feeding System
- External And Controls System

Basic Configuration

Configuration function

The machine may be broadly divided into the following 7 functional blocks: engine control system, document exposure/feeding system, laser exposure system, image formation system, pickup/transport/delivery system, fixing system, and externals/auxiliary control system.

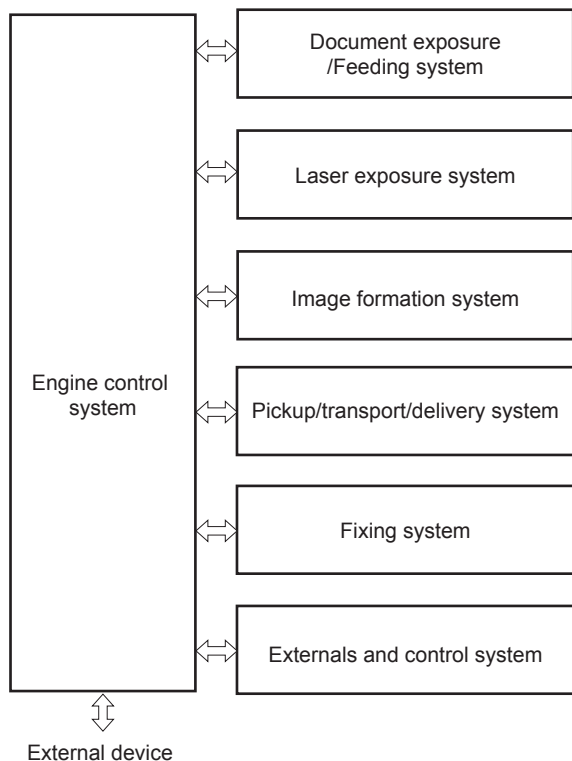

F-2-1

Basic Sequence

Basic Sequence of Operation

The engine controller controls the operation sequence. The following table provides an outline of machine operation occurring from when the power switch is turned on to when printing ends and motors stop, indicating the purposes of intervals and engine operation. For details of various loads, see the timing chart.

	Interval	Purpose	Remarks
WAIT (Wait)	From power-ON until initial drive for main motor is completed.	To clear potential from the drum surface and to clean the transfer roller. Also to bring the heater temperature up to the targeted temperature.	Detect whether the Toner cartridge is installed or not.
STBY (Standby)	From the end of the WAIT period or the LSTR period until the print command is sent from the main controller. Or, from the end of the LSTR period until power switch is turned OFF.	To keep the printer ready to print.	
INTR (initial rotation)	From the input of the print command from the main controller until the pick-up solenoid is turned ON.	To stabilize the photosensitive drum sensitivity in preparation for printing. Also to clean the transfer roller.	
PRINT (print)	From the end of the INTR period until the top of page sensor detects the trailing edge of paper.	To form image on the photosensitive drum based on the VIDEO (/VD01, /VD02, VD01, VD02) signals input from the main controller, and to transfer the toner image onto paper.	
LSTR (last rotation)	From the end of PRINT period until the Main motor stops.	To deliver the last paper completely out of the printer.	Return to the INTR period as soon as another print command is sent from the main controller.

T-2-1

Print Sequence

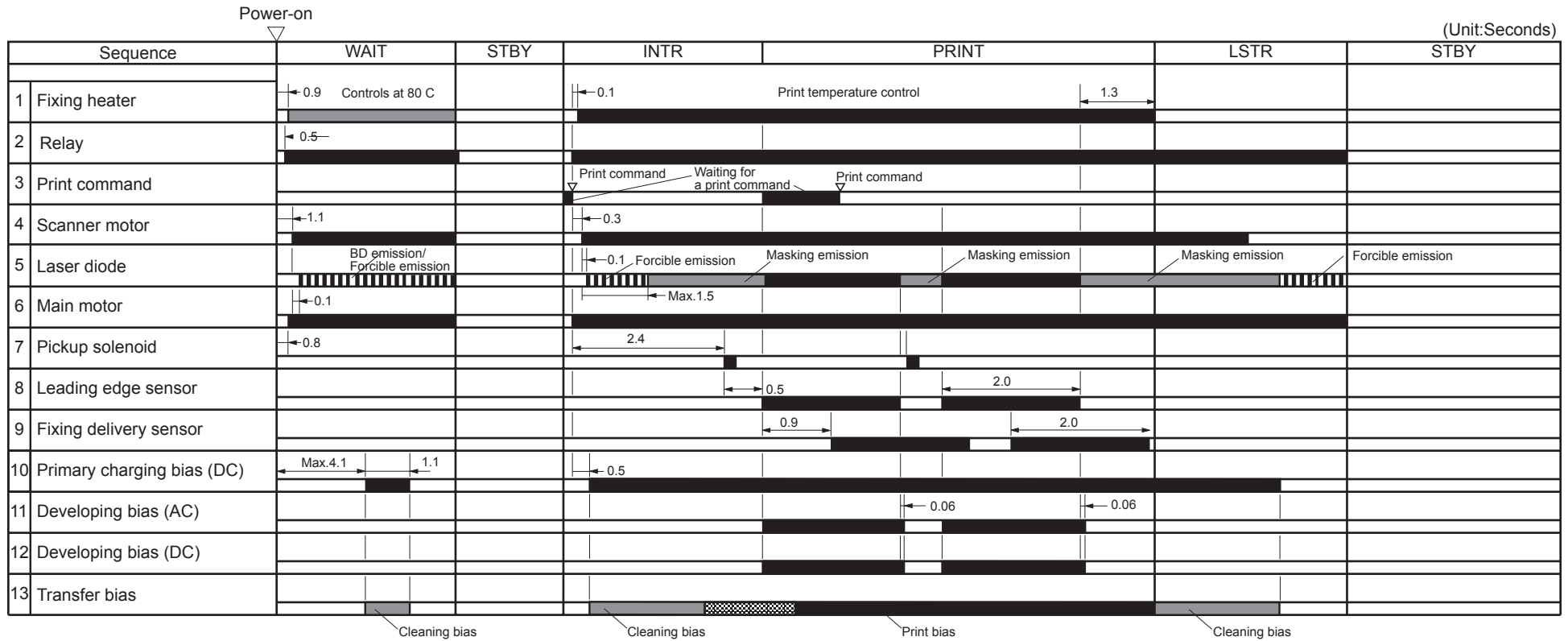

F-2-2

Controller System

Main Controller

General description

The Main Controller receives print information from the Reader and ADF, Fax, and network. Video data is created from the received print information and is sent to the Engine Controller.

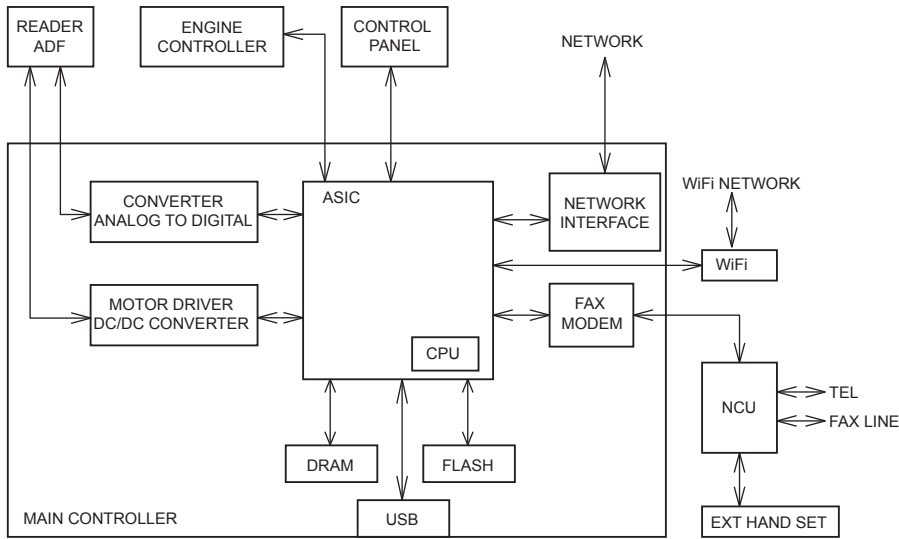

F-2-3

Engine Controller

General description

Engine controller is the circuit to control the operation sequence of the host machine and it is controlled by the CPU inside the engine controller.

When the power is turned ON and DC power is supplied through the low voltage power inside engine controller, CPU starts the printer operation control.

Then, CPU drives the loads such as laser diode, motors and solenoids etc. according to the image data that is input by the main controller when status becomes stand-by mode.

The following is the block diagram of this circuit.

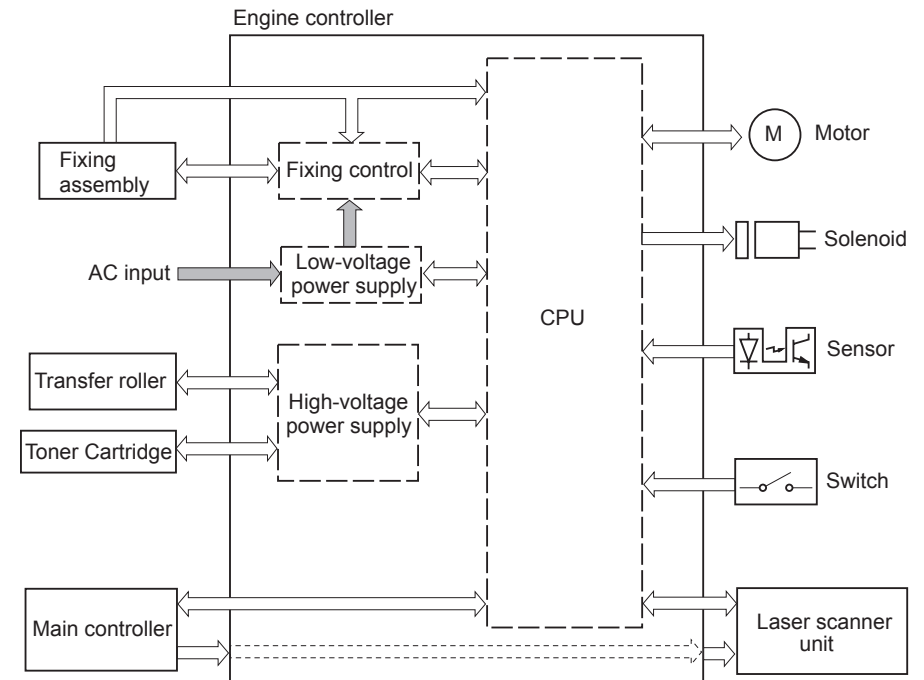

F-2-4

Service Works

■ At parts replacement

No work is required for this product at parts replacement.

■ Maintenance

No periodically replaced parts, durable parts or periodical service is set for this product.

■ Notes on service works

None.

Document Exposure/Feeder System

Document Exposure System

Overview

item	function / method
document exposure	LED
document scan	Book mode: scan by the shift of the contact sensor (CS) SADF/DADF: document stream reading by fixed contact sensor (CS)
Copey Board Scanning resolution	600 dpi X 600 dpi
ADF scanning resolution	300 dpi X 300 dpi
number of gradations	256 gradations
magnification	50% to 400% horizontal: image processing by Main controller PCB vertical: change of carriage shift speed, image processing by Main controller PCB
lens	rod lens array
CMOS sensor	number of lines: 1 line number of pixels: 5184 pixels as total pixels (5126 pixels as effective pixels) maximum document scanning width: 216 mm
CS drive control	drive control by Reader motor
document size detection	none

T-2-2

Major Components

Followings are the major components for Document Exposure System.

- The contact sensor to scan document
- The Reader motor, the drive pulley, the drive belt, to shift the contact sensor

In image scanning control, the contact sensor is shifted by rotating the Reader motor based on the drive signal from the SCNT PCB and scan the original on the copyboard glass. When ADF is in use, image is scanned by feeding the originals by ADF instead of shifting the contact sensor.

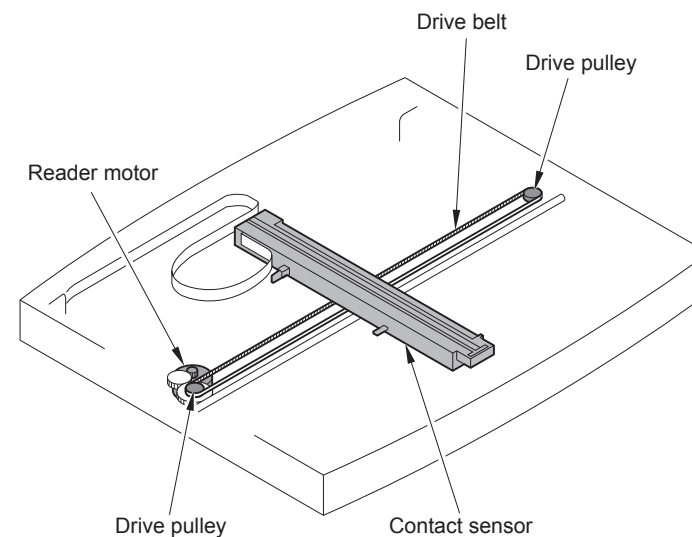

F-2-5

Document Feeder System

Overview

SADF

The Single-side Auto Document Feeder (SADF) mounted onto this host machine is dedicated to stream-reading.

1 motor (SADF motor) is engaged in pickup/feeding/delivery.

At the start of copy/fax/scan, the SADF motor is driven by the drive command from the Main controller to pickup/feed the originals set face up on the original tray one by one in order from the top. The original is scanned by the contact sensor when moving through the copyboard glass, and then delivered face down to the original delivery assembly.

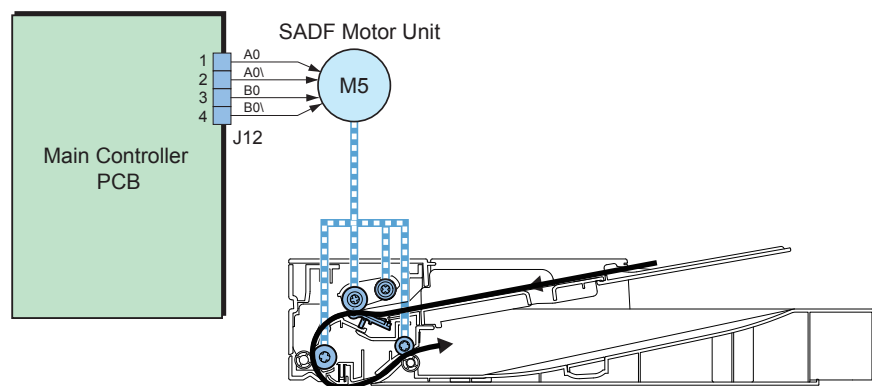

F-2-6

DADF

Pickup/Feed/Delivery Operation

The Double-side Auto Document Feeder (DADF) mounted onto this host machine is dedicated to stream-reading.

1 motor (DADF motor) is engaged in pickup/feeding/delivery.

At the start of copy/fax/scan, the DADF motor is driven by the drive command from the Main controller to pickup/feed the originals set face up on the original tray one by one in order from the top. The original is scanned by the contact sensor when moving through the copyboard glass, and then delivered face down to the original delivery assembly.

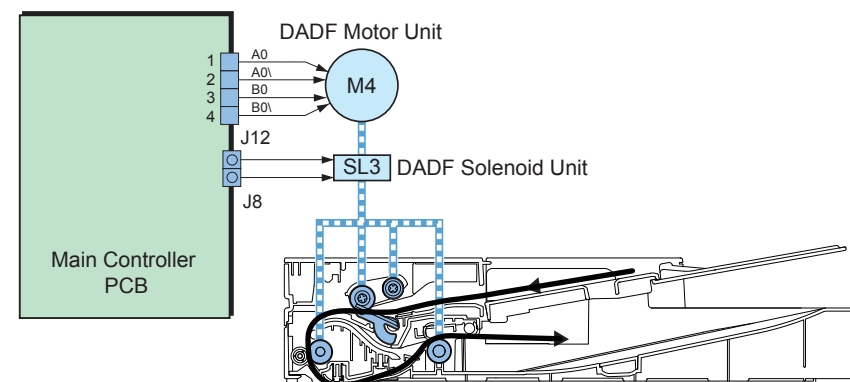

F-2-7

Operation at duplex reading

- Pickup to Reading of the 1st side

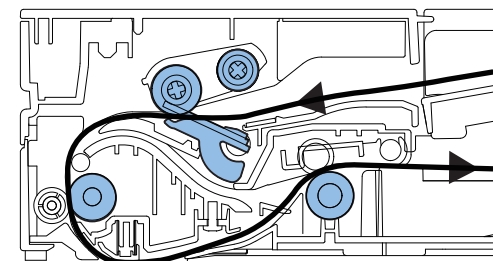

F-2-8

- Reverse to Reading of the 2nd side

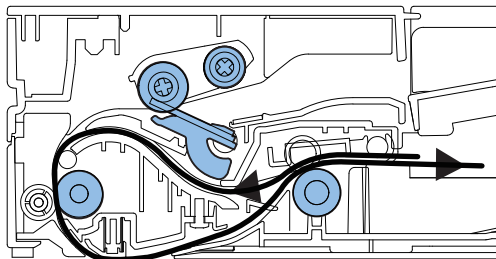

F-2-9

- Delivery

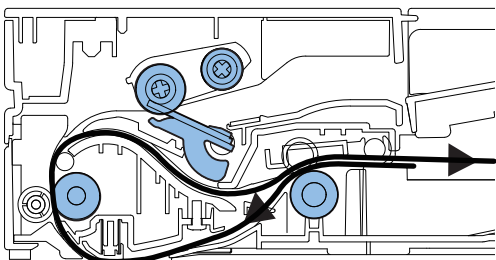

F-2-10

■ Various Control

● Original Detection

There are two types of original detection in this equipment.

1. Original Presence / Absence Detection

Detected by DS (Document Sensor)

As the actuator is pushed up by placing an original on the Original Tray, DS of SADP is turned ON (light is blocked => light is transmitted) and DS of DADF is turned OFF (light is transmitted => light is blocked) so that presence of an original is detected.

2. Detection of the End of the Original

Detected by the DES (Document End Sensor)

The leading edge of the original that is fed pushes up the actuator, activating the DES (light shielded => light transmitted) and resulting in detection of the reach of the leading edge of original. Furthermore, when the trailing edge of the original passes the actuator position, the actuator returns to the original position, inactivating the DES (light transmitted => light shielded). The trailing edge of the original is detected by this mechanism. The original length that can be scanned with this equipment is less than 400 mm. Passing of the original longer than this results in jam stop. The original length is calculated by the time it takes from detection of the leading edge of the original to detection of the trailing edge of the original.

Note:

There is no function to detect the original size (original width, length) in this equipment.

In the case of SADP

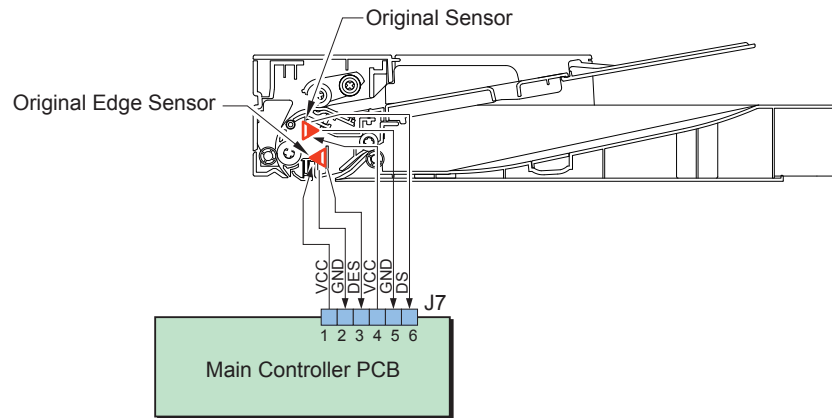

F-2-11

In the case of DADF

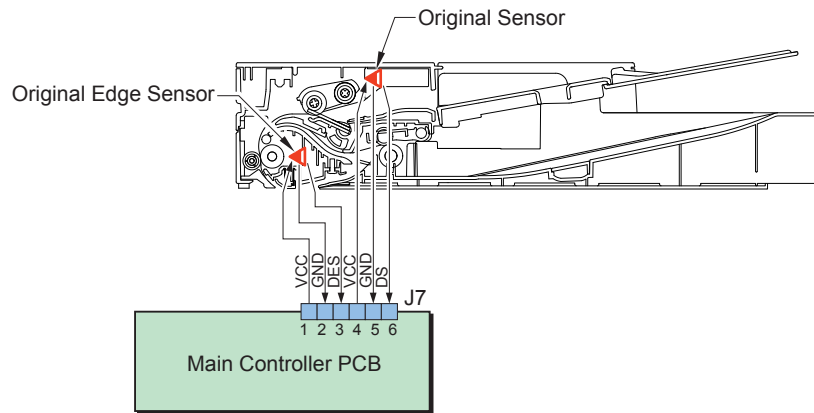

F-2-12

● Jam Detection

The following cases are judged as jam.

1. In case of delay in reaching DS/DES or stationary during scanning of original
2. In case DS/DES is detected as ON at power-on (residual paper jam)
3. In case of detecting original of which length is 400 mm or longer

• Operation after Detection of Jam

The host machine stops scanning operation and displays "CHECK DOCUMENT" on the control panel. No jam code is displayed. In case of the model equipped with fax function (with built-in speaker), the warning beep occurs at the detection of jam.

• How to release Jam

Remove the jammed paper and open / close the SADP/DADF upper cover

Service Works

■ At parts replacement

No work is required for this product at parts replacement.

■ Maintenance

No periodically replaced parts, durable parts or periodical service is set for this product.

■ Notes on service works

None.

Laser Exposure System

Overview

Overview

The laser exposure system forms static latent images on the photosensitive drum according to the VIDEO signals sent from the main controller, and is comprised of the laser driver and scanner motor, etc. These are controlled by the engine controller. The following is the outline.

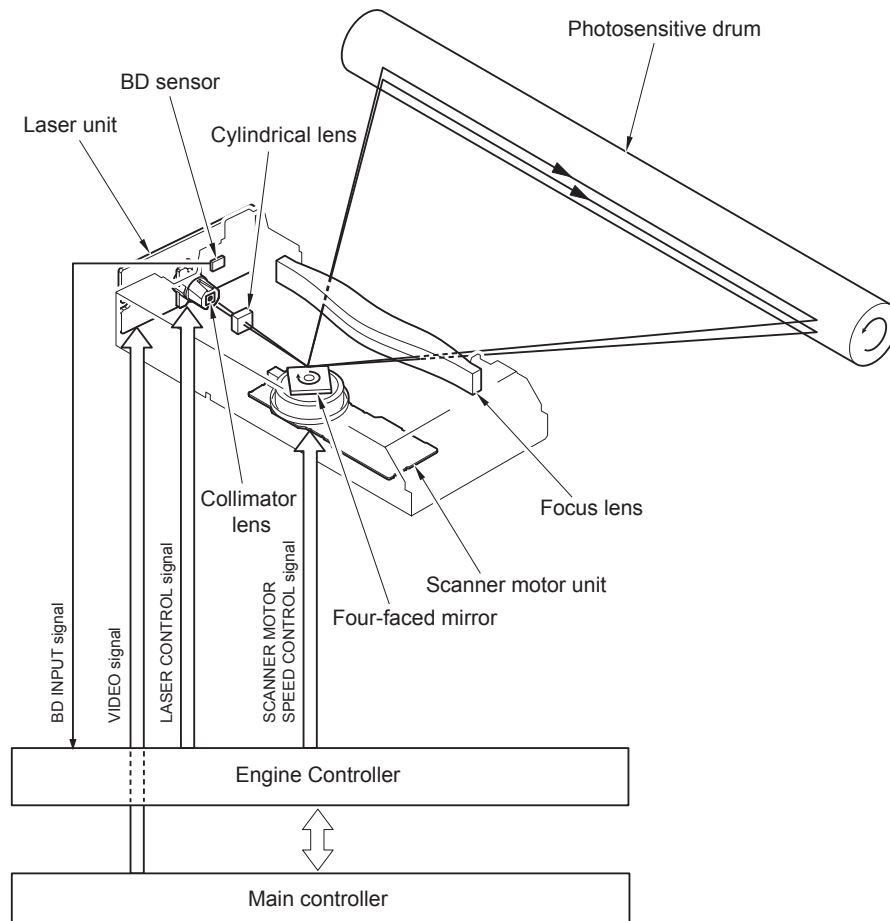

F-2-13

The operational sequence of the laser scanner unit is described below.

- 1) When the Main controller sends print instruction command, the Engine controller rotates the Four-faced mirror, causing the Scanner motor to rotate.
- 2) When the Scanner motor starts to rotate, the Engine controller emits the laser forcibly using the Laser control signal, causing the Engine controller to start rotation control for the Scanner motor.
- 3) The Engine controller controls to keep a constant speed of rotation of the Scanner motor using the Scanner motor speed control signal.
- 4) After the rotation speed of the Scanner motor reaches its target, the Main controller sends VIDEO signals to the Laser driver PCB.
- 5) The Laser driver emits laser diode according to these signals.
- 6) The laser beam passes through the collimator lens and the cylindrical lens and enters the Four-faced mirror rotating at a constant speed.
- 7) The laser beam reflected by the Four-faced mirror is focused on the Photosensitive drum via the image-forming lens at the front of the Four-faced mirror.
- 8) When the Four-faced mirror rotates at a constant speed, the laser beam on the Photosensitive drum is scanned on the Photosensitive drum at a constant speed.
- 9) When the Photosensitive drum rotates at a constant speed and the laser beam is scanned on the Photosensitive drum at a constant speed, latent images are formed on the Photosensitive drum.

Controlling the Laser Activation Timing

Laser ON/OFF Control

In this control, the laser driver turns on/off the 2 laser diodes (LD1, LD2) according to the laser control signal sent from the engine controller.

The following is the circuit diagram of the laser control.

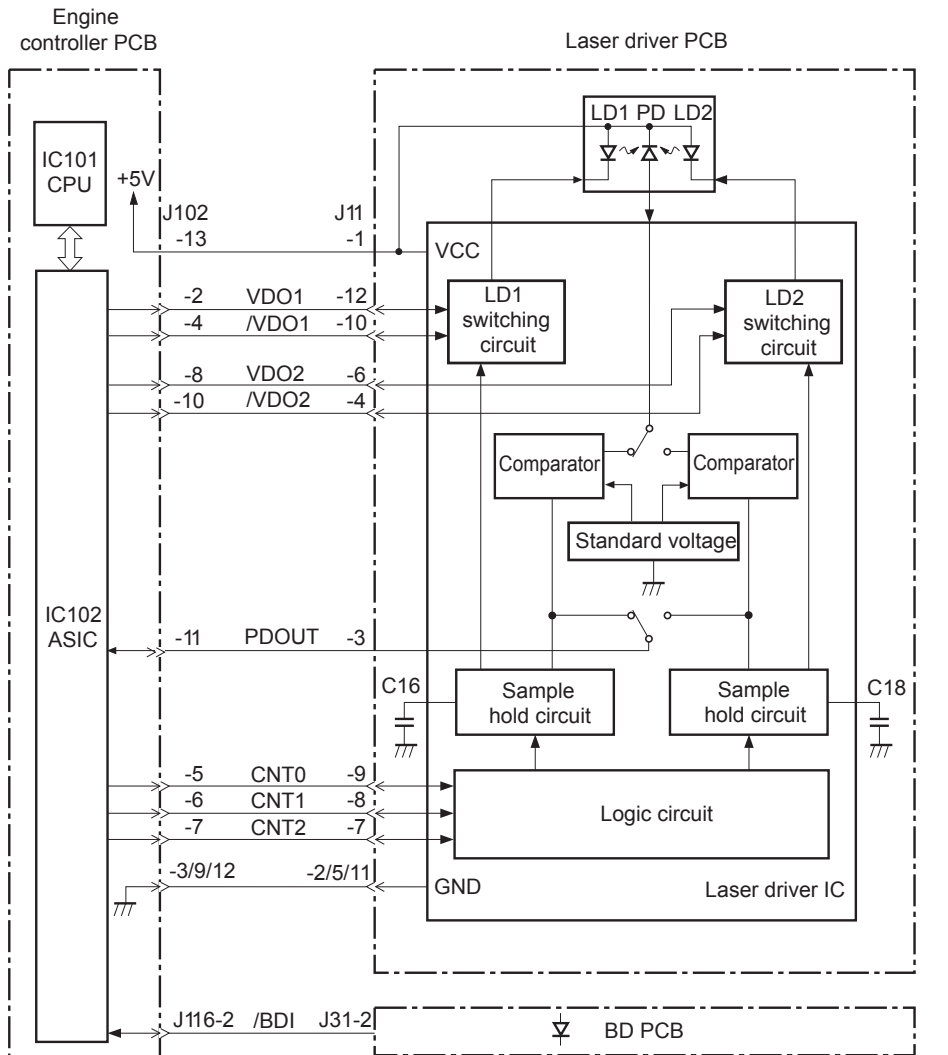

F-2-14

The engine controller sends the laser control signals (CNT0, CNT1, CNT2) for changing the operation mode of the laser to the logic circuit in the laser driver IC, as well as the video signals (VDO1, /VDO1, VDO2, /VDO2) for image formation.

The laser driver IC executes laser control according to the combination of the CNT0, CNT1, CNT2 signals.

The following is the combination of the laser control signal (CNT0, CNT1, CNT2).

Operation mode	CNT0	CNT1	CNT2	Details
Standby	L	L	L	Laser control OFF
Print	H	H	H	Can emit the laser according to the video signal
LD1 forced ON	L	H	L	LD1 forcibly turned ON
LD2 forced ON	H	L	L	LD2 forcibly turned ON
LD forced OFF	H	H	L	LD1, LD2 forcibly turned OFF

T-2-3

Horizontal Sync Control

This is the control to adjust the writing position in the image horizontal direction.

The following is the details of control procedure.

- 1) The engine controller controls the laser control signal during unblanking (*) to emit the laser diode (LD) forcibly.
- 2) The BD PCB exists on the scanning route of the laser beam, which is sent to the BD PCB.
- 3) The BD PCB detects this laser beam, creates BD input signal (/BDI) and sends it to the engine controller.
- 4) The engine controller creates horizontal sync signals (/BD) based on /BDI signal and sends the /BD signal to the main controller.
- 5) When /BD signal is input, the main controller outputs the video signal (VD0, /VD0) to the engine controller to adjust the writing position in image horizontal direction.

*: Unblanking period

The period during which the laser diode is emitted in non-image area.

■ Scanner Motor Fault Detection

This is the detection of faults in the laser scanner unit.

When the laser scanner unit falls into either of the following status, the engine controller judges it as a fault in the laser scanner unit system and notices the status of fault to the main controller.

The operations of the host machine are stopped.

1. Fault in BD input

At startup of the scanner, /BDI signal cannot be detected within 0.1 sec from the completion of forced acceleration of the scanner motor.

2. Fault in startup

During activating the scanner motor at startup of the scanner, the motor rotation exceeds the specified range (98.3 to 101.7%).

3. Fault in control

After startup of the scanner completes correctly, /BDI signal exceeds the specified value of cycle 2000 msec consecutive times.

Service Works

■ At parts replacement

No work is required for this product at parts replacement.

■ Maintenance

No periodically replaced parts, durable parts or periodical service is set for this product.

■ Notes on service works

None.

Image Formation System

Overview/Configuration

Overview

The image formation system is the core of this equipment; it forms toner images on papers. The image formation system is comprised of the following components. The engine controller controls the laser scanner unit and high-voltage power supply circuit and forms images based on the video signals on papers. The following are the details of print process for this equipment and the functions of image formation.

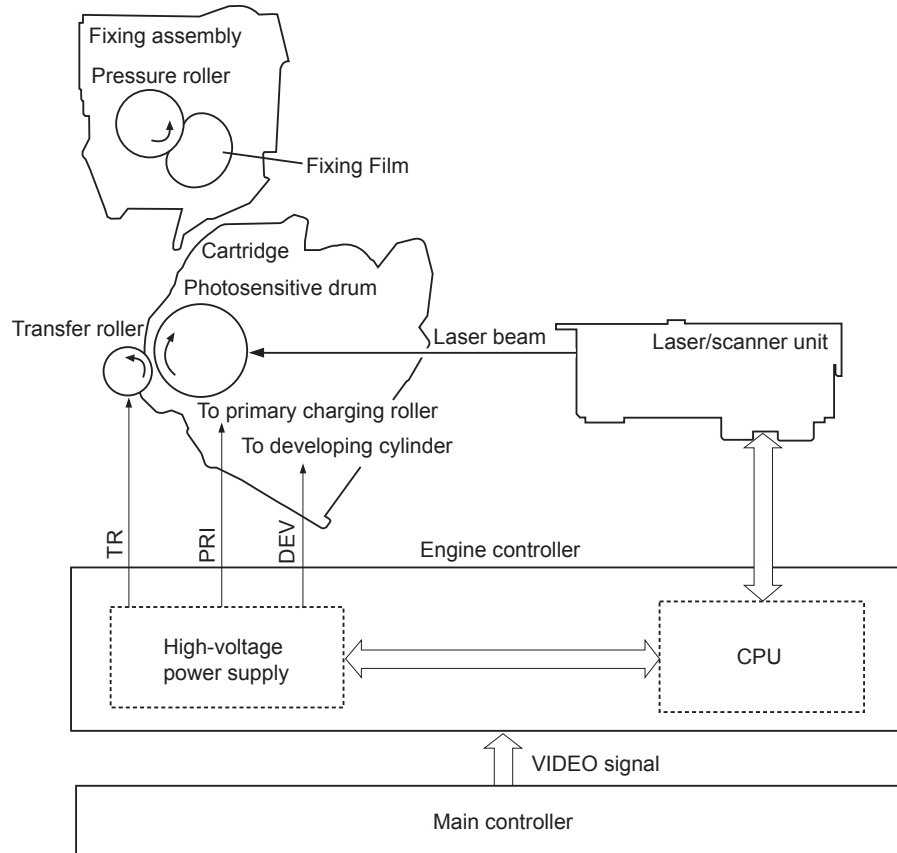

F-2-16

Print Process

This explains the basic process of the operations that a printer executes for image formation. The print process of this equipment is divided largely into 5 blocks, 7 steps. Toner images are formed on papers by executing the steps of each block in order. The following are the blocks of print process and the steps.

1. Static latent image formation block
 - Step 1: Primary charging
 - Step 2: Laser beam exposure
2. Development block
 - Step 3: Development
3. Transfer block
 - Step 4: Transfer
 - Step 5: Separation
4. Fixing block
 - Step 6: Fixing
5. Drum cleaning block
 - Step 7: Drum cleaning

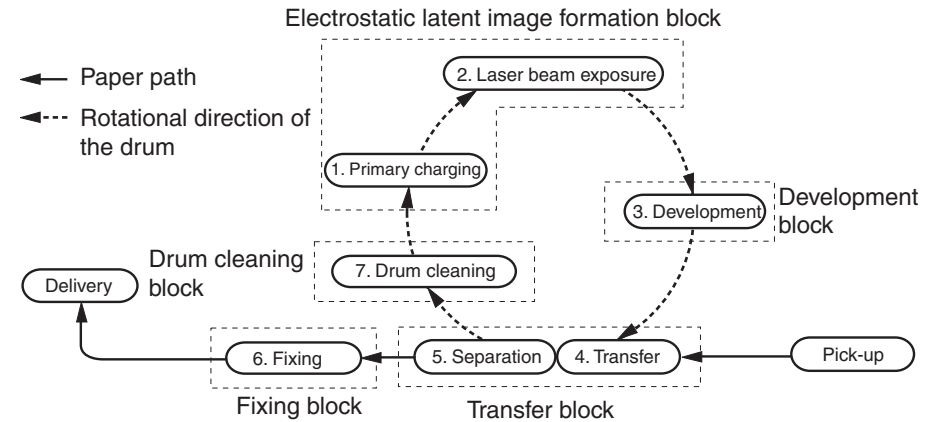

F-2-17

Static Latent Image Formation Block

This block is comprised of two steps and forms static latent images on the photosensitive drum.

When the final step of this block completes, negative charge remains at dark areas on the drum surface where laser beam has not been exposed, and negative charge is eliminated from bright areas on the drum surface with laser beam exposed. The images on the drum with negative charge are called static latent images because human eyes cannot detect them.

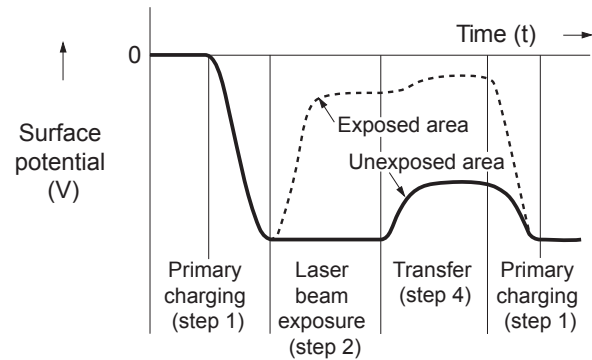

F-2-18

Step 2: Laser beam exposure

In this step, static latent images are formed on the photosensitive drum with laser beam. When laser beams are scanned on the photosensitive drum negatively charged, bright areas lose their charges, eliminating negative potential on the surface of the photosensitive drum; on those portions, static latent images are formed.

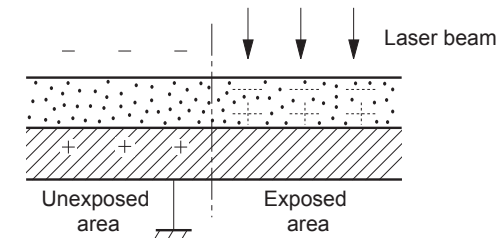

F-2-20

Step 1: Primary charging

For preparation of latent image formation, the surface of photosensitive drum is charged with even negative potential. In this primary charging, the charge is applied from the primary charging roller directly to the photosensitive drum.

DC bias is applied to the primary charging roller to maintain an even potential on the surface of the photosensitive drum.

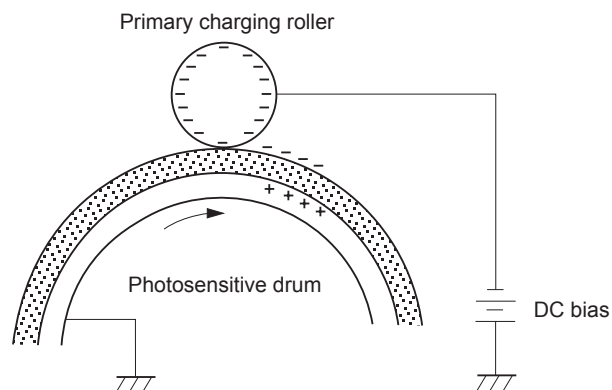

F-2-19

Development Block

This block is comprised of one step; it puts toners to the static latent images on the surface of the photosensitive drum and visualizes the images using toner projection development. The toner projection development makes the toner jump on the surface of the photosensitive drum and develops the images.

The toner (developer) used for this equipment is a one-component toner that comprises magnetic body and resin, etc.

Step 3: Development

Toner is affixed to static latent images on the surface of the photosensitive drum.

The toner is charged negatively by friction between the developing cylinder and the surface of the developing blade.

An area on the photosensitive drum exposed with laser beam has higher potential than the developing cylinder; the potential difference between the drum surface and the cylinder enables the toner to jump on the drum surface and makes them visible images.

AC bias superimposed with the development DC negative bias is applied to the developing cylinder.

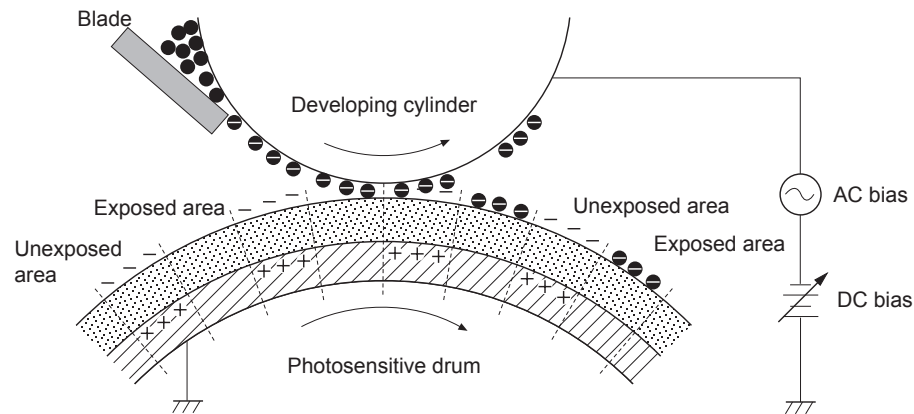

F-2-21

Transfer Block

This block is comprised of two steps; it transfers toner images on the surface of the photosensitive drum to papers.

Step 4: Transfer

In this step, toner images on the photosensitive drum are transferred to papers.

This equipment applies DC positive bias to the transfer roller facing the photosensitive drum and charges papers positively. This enables toner negatively charged on the surface of the photosensitive drum to be transferred to papers.

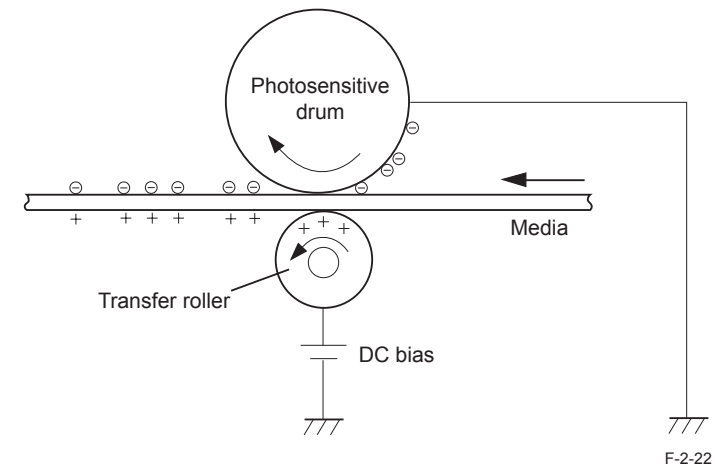

F-2-22

Step 5: Separation

In this step, DC negative bias is applied to the static eliminator according to the elasticity of papers to separate the papers from the photosensitive drum. The static eliminator is used to stabilize the paper feed system (prevention of toner stray that appears as polka-dots on print images in a low-temperature, low-humidity environment), and neutralizes the electric charge at the back of papers.

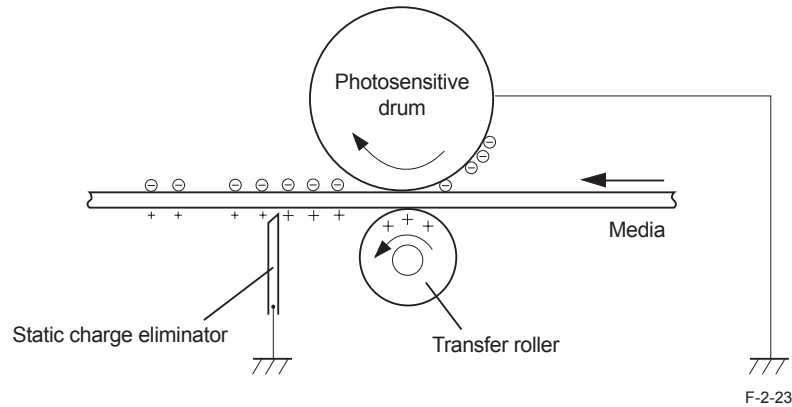

Fixing Block

This block applies pressure and heat to papers and the toner on them to fix toner images to the papers.

Step 6: Fixing

This step employs on-demand fixing that fixes toner images transferred to papers on the papers.

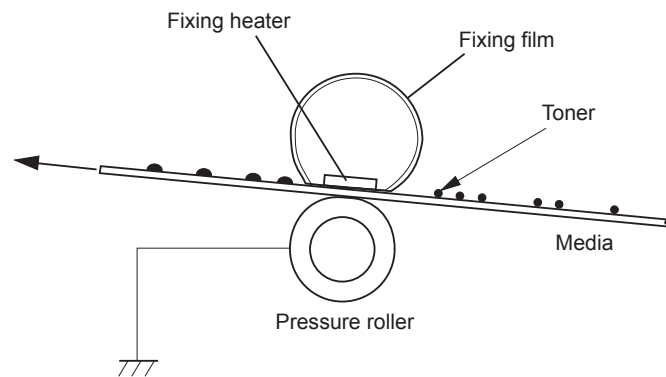

Drum Cleaning Block

The drum cleaning block removes the toner remained on the photosensitive drum.

Step 7: Drum cleaning

In this step, toner remained on the photosensitive drum is removed.

The cleaning blade scrapes the leftover toner on the surface of the photosensitive drum; the toner is collected into the cleaner container.

By implementing the above step, the surface of the photosensitive drum is cleaned.

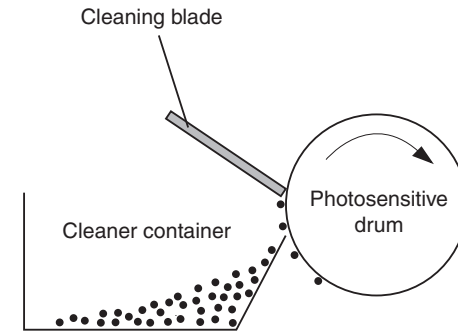

High-Voltage Control

Overview

This circuit is comprised of the circuits that apply biases to the primary charging roller, developing cylinder, transfer roller, and the fixing control circuit. The CPU of the engine controller controls the high-voltage power supply circuit to generate these biases. The fixing control circuit executes heater control of the fixing assembly according to the instruction by the CPU of the engine controller.

The following is the block diagram of this circuit.

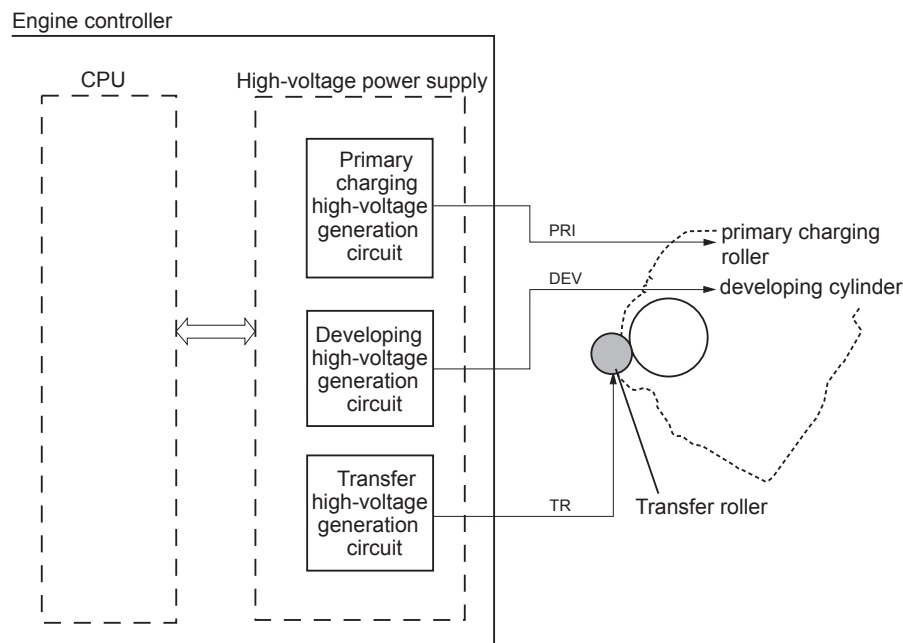

F-2-26

Generating Primary Charging Bias

The primary charging bias (PRI) is a DC negative bias that is output to apply an even negative potential to the surface of the photosensitive drum. The primary charging high-voltage generating circuit in the high-voltage power supply circuit generates this bias. The high-voltage power supply circuit applies the generated primary charging bias to the primary charging roller at a specified timing.

The primary charging bias varies in conjunction with the developing bias according to the information of image density sent from the main controller.

Generating Developing Bias

The developing bias is a DC negative bias that is output to affix toner to the static latent images formed on the photosensitive drum. This bias is a development DC and AC superimposed bias and generated by the development high-voltage generating circuit in the high-voltage power supply circuit.

The high-voltage power supply circuit applies the generated developing bias to the developing cylinder at a specified timing.

The developing bias varies in conjunction with the primary charging bias according to the information of image density sent from the main controller.

Generating Transfer Bias

Transfer bias (TR) is a bias that is output to transfer toner to papers. There are two types of bias; DC positive bias and DC negative bias, and generated by the transfer high-voltage generating circuit in the high-voltage power supply circuit. The DC positive bias is output at the time of toner transfer, and the DC negative bias at the time of cleaning the photosensitive drum.

The high-voltage power supply circuit applies the generated transfer bias to the transfer roller according to each print sequence.

Each print sequence is described below.

- **Cleaning bias:**
The bias to move (clean) the toner attached to the transfer roller to the photosensitive drum at the time of warming up or last rotation sequence.
The transfer negative bias is applied to the transfer roller.
- **Paper intervals bias:**
The bias to prevent the toner remained on the photosensitive drum from attaching to the transfer roller at paper intervals during continuous printing. A minor transfer positive bias is applied to the transfer roller.
- **Print bias:**
The bias to transfer the toner on the surface of the photosensitive drum to papers at the time of print sequence. The transfer positive bias is applied to the transfer roller.

Toner Cartridge

Toner Level Detection

4in1Model

Toner level is detected by the Toner Sensor (Magnetic Sensor). When a Toner Cartridge is installed, the Toner Sensor contacts with the lower side of the cartridge and it converts the magnetic changes in the cartridge into voltage.

Then, CPU of engine controller PCB compares the output voltage of the Toner Sensor with the reference value to detect the toner level.

Toner level detection is performed at startup of the Main Motor.

The toner level detection sequence starts after the Main Motor is started up and stabilization time (200msec) has passed. The toner level detection sequence continues until the Main Motor stops. There are following 2 types of toner level detection sequence: sequence at warm-up rotation when opening door or turning ON the power, and sequence at normal rotation.

1) Sequence at normal rotation

From the start of detection, detection value of magnetic toner is sampled for every 5 msec. Remaining toner level is judged based on the average value and ripple value (V Peak to Peak) of the Magnetic Sensor output while the Stirring Stick makes a full turn.

Time the Stirring Stick makes a full turn and number of samples

In case the process speed is 150mm/sec, time is 1.9 sec (380 samples).

In case the process speed is 75mm/sec, time is 3.8 sec (760 samples).

2) Sequence at warm-up rotation

Conditions of sampling and remaining toner level judgment are the same as those mentioned above.

However, in the case that toner Low is detected even at once during warm-up rotation sequence, toner Low is remained to be displayed.

3In1 Model

This equipment has no function of toner level detection.

Specification of Toner level display

Toner level can be checked by pressing Status Monitor/Cancel key and selecting toner level. The display of toner level is just a rough indication.

In the case of 4-in-1 models, the toner level is corrected depending on the usage conditions. In the case of 3-in-1 models, a predicted value is displayed because they do not have the function to correct the level.

In the following cases, status of toner level is considered as unidentified, and OK (100%) is displayed on the panel.

- After power-on
- Right after recovery from engine sleep mode
- During opening/closing the door
- When the cartridge is not installed

4in1 Model

Display	Handling	Complement
<Prepare a cartridge.>	This message notifies you that a toner cartridge needs to be replaced soon. Shake the toner cartridge to evenly distribute the toner inside the cartridge. Replace the toner cartridge if you see this message before you start to print a large job.	
<The amount remaining in the cartridge is very low.>	The toner cartridge is about to reach the end of its lifetime. Shake the toner cartridge to evenly distribute the toner inside the cartridge. If this does not improve the print quality, replace the toner cartridge.	<ul style="list-style-type: none"> • If this message is displayed, the incoming fax will be stored in the memory without being printed. Also, reports are not printed, even if they are set to be printed automatically. • You can continue printing when this message is displayed, but the print quality may deteriorate. <p>When a message is displayed</p> <ul style="list-style-type: none"> • If the message is displayed when the machine is receiving a fax or automatic report output is set, received faxes and reports will be stored in the machine so that they do not appear faded after they are printed. • To continue printing even if the toner is running low, set <Continue Print. When Near Cart. Life End> to <On>.

T-2-4

3in1 Model

Display	Handling
<Preparing a cartridge is recommended.>	This message notifies you that a toner cartridge needs to be replaced soon. Shake the toner cartridge to evenly distribute the toner inside the cartridge. Replace the toner cartridge if you see this message before you start to print a large job. You can continue printing when this message is displayed, but the print quality may deteriorate.

T-2-5

Operation when toner level is Low/Nearly Out

Operation when toner level is Low or Nearly Out is as follow. If another job which can be processed is introduced while there is a job which is stopped due to "Nearly Out", the job is output by overtaking the preceding job.

List of stop processing according to toner level

Copy		PDL		Receive print		Manual report		Auto report	
Low	Nearly Out	Low	Nearly Out	Low	Nearly Out	Low	Nearly Out	Low	Nearly Out
Yes	Yes	Yes	Yes	Yes	No	Yes	Yes	Yes	No

Yes: Continues

No: Page output is stopped immediately after detection, but it can be continued by user mode.

T-2-6

Toner Cartridge Absence/Presence Detection

The engine controller detects the position of the Toner cartridge detection flag to judge the absence/presence of the Toner cartridge.

At the time of turning on the power or closing the upper cover, the engine controller judges the position of the Toner cartridge flag based on the output result of the leading edge sensor (PS751).

When the output result of the leading edge sensor (PS751) is L, it is judged that the Toner cartridge is absent; If being H, it is judged that the Toner cartridge is present.

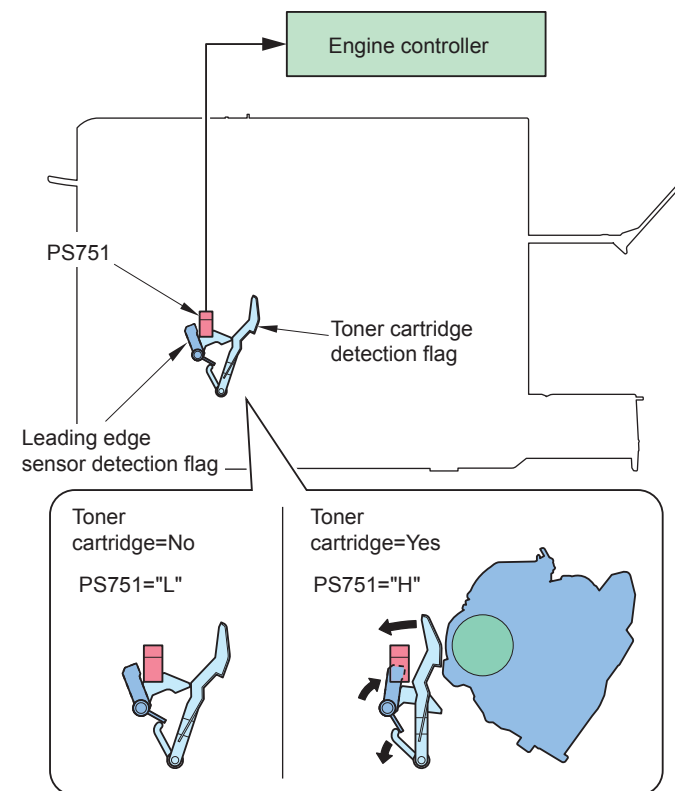

F-2-27

The leading edge sensor performs both this detection and paper feed detection. Therefore, the engine controller cannot make a judgment of 'Toner cartridge absent' or 'jam occurrence' when jam occurs.

The engine controller judges this case as 'Toner cartridge absent' and notices it to the main controller.

If jam occurs when 'Toner cartridge absent' is detected, check if there is a fault in the leading edge sensor and the detection flag.

Service Works

■ At parts replacement

No work is required for this product at parts replacement.

■ Maintenance

No periodically replaced parts, durable parts or periodical service is set for this product.

■ Notes on service works

None.

Fixing System

Overview/Configuration

Overview

Fixing/delivery system consists of the fixing film unit, pressure roller and delivery roller etc. These rollers are driven by the main motor (M1). The paper that toner is transferred to are heated by the fixing heater of the fixing film unit and pressured by the pressure roller. The paper that toner is fused on is delivered from the fixing assembly, detected by the fixing delivery sensor (PS701) and the paper width sensor (PS702), and then delivered to the delivery tray by the delivery roller.

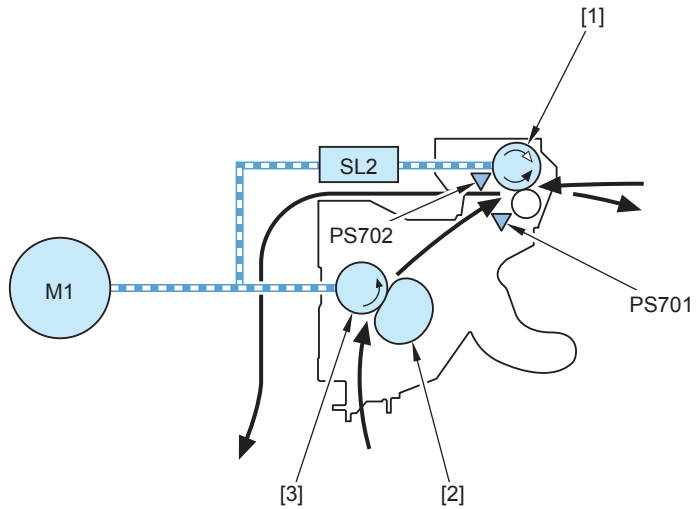

- [1] Delivery Roller
- [2] Fixing Film Unit
- [3] Fixing Pressure Roller
- PS701 Fixing delivery sensor
- PS702 Paper width sensor
- M1 Main motor

T-2-7

Main Parts of Fixing assembly

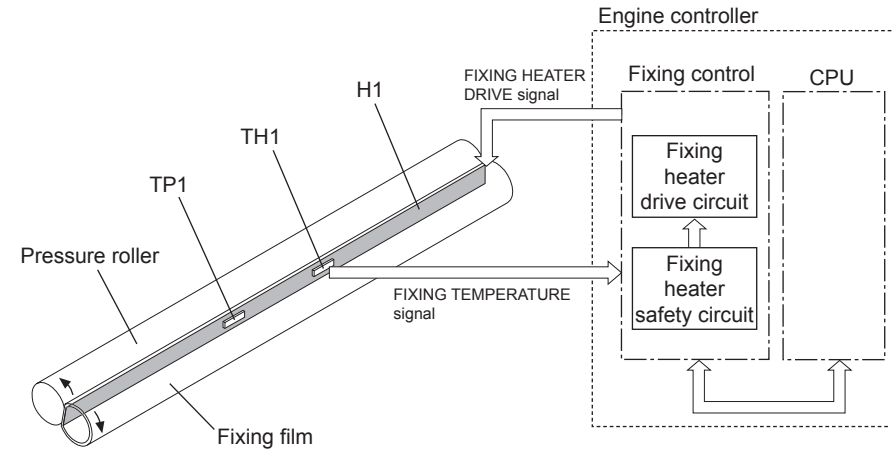

F-2-29

H1	: Fixing heater	For heating the fixing film (ceramic heater)	1 pc
TH1	: Main thermistor	For controlling the fixing heater temperature (contact type thermistor)	1 pc
TP1	: Temperature fuse	For detecting the fixing heater overheat (non-contact type fuse) When the heater overheats, the fuse melts to cut the power supply to the heater.	1 pc

T-2-8

Various Control Mechanisms

Fixing Temperature Control

Heater Temperature Control

The heater temperature control is to keep the fixing heater in the fixing film unit to the specified temperature.

The engine controller monitors the fixing heater temperature detection signal (FSRTH) and outputs the fixing heater drive signal (FSRD) according to the detected temperature.

The fixing heater drive PCB controls the fixing heater according to this signal to keep the fixing heater temperature within the target values.

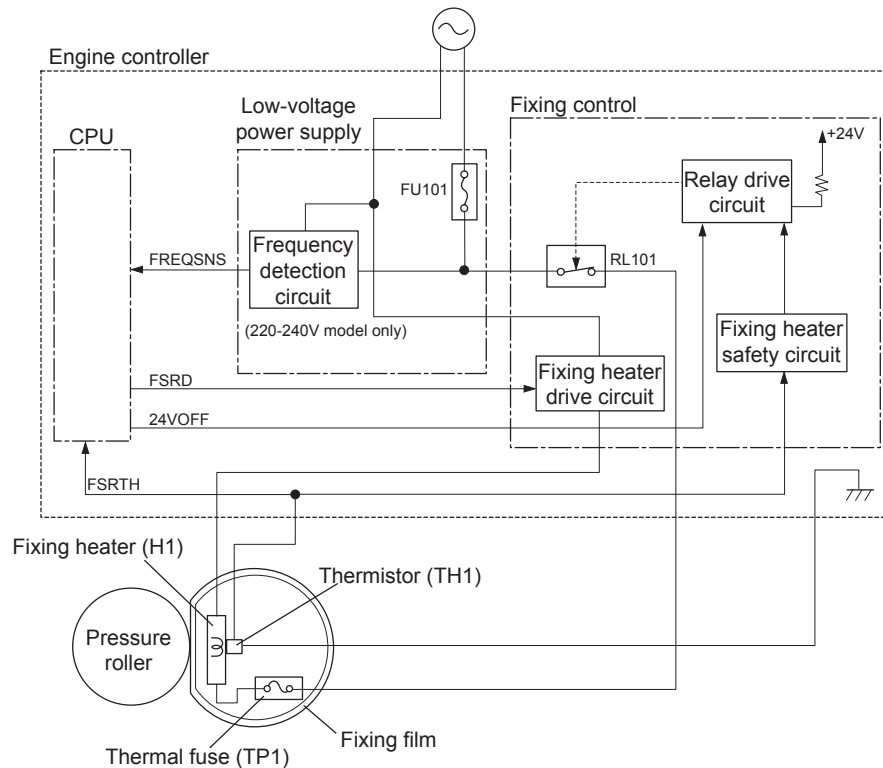

F-2-30

There are 11 types of target fixing temperature depending on the fixing mode. These types are according to the paper type settings and resolution settings on a driver.

Protective Functions

Protective Function of fixing assembly

Host machine carries the following 3 functions to prevent the fixing heater from overheating.

1) Protective function by CPU

CPU of engine controller monitors the thermistor (TH1) temperature consistently. When TH1 reaches approx 220 deg C, CPU determines that the fixing heater is overheating and stops the fixing heater drive signal (FSRD) output and also turns OFF relays to shut the power supply to fixing heater.

2) Protection function by fixing heater safety circuit

Fixing heater safety circuit monitors the thermistor (TH1) temperature consistently. When TH1 reaches approx 235 deg C, it determines that the fixing heater is overheating and the fixing heater safety circuit turns OFF the relay drive circuit to shut the power supply to the fixing heater.

3) Protection function by temperature fuse (TP1)

When the fixing heater temperature rises abnormally and temperature fuse (TP1) temperature reaches approx 226 deg C, TP1 opens to shut the power supply to the fixing heater.

Failure detection

With this machine, 8 types of failure detection are available.

1) Initial startup failure detection

When temperature of the Fixing Assembly does not exceed 50 deg C within 1.48 sec after the start of temperature control performed at initial rotation, it is judged as initial startup failure.

2) Initial Thermistor open detection

When temperature of the Fixing Assembly does not exceed 35 deg C within 1.48 sec after the start of temperature control at warm-up rotation temperature control or at cleaning mode, it is judged as Thermistor open failure.

3) Short circuit of Thermistor/abnormal high temperature detection

When temperature of the Fixing Assembly is 220 deg C or higher for 30 consecutive times by monitoring the temperature for every 5 msec, it is judged as Thermistor short circuit failure. In addition, this function also doubles as abnormal high temperature detection function of the Fixing Assembly.

4) Abnormal low temperature detection

After temperature of the Fixing Assembly exceeds 50 deg C at least once, monitor temperature of the Thermistor for every 5 msec. It is judged as heater abnormal low temperature when the following condition is detected 240 consecutive times: the temperature is 100 deg C or lower while paper is at fixing nip, or it is 55 deg C or lower during paper interval temperature control or at cleaning mode.

5) Thermistor open detection

After temperature of the Fixing Assembly exceeds 50 deg C, monitor temperature of the Thermistor for every 5 msec. When it is detected that the temperature is lower than 20 deg C for 6 consecutive times, it is judged as Thermistor open failure.

6) Startup failure detection

If temperature of the Fixing Assembly is 100 deg C or higher when the machine becomes in pickup enabled state after entering fixing low voltage inlet sequence, it is judged as startup failure.

7) Thermistor low temperature detection 2)

Temperature of the Thermistor is monitored for every 200 msec when paper is at fixing nip during the Fixing Assembly control. When the temperature is lower than 135 deg C (120 deg C), increase the value of low temperature detection counter by 1 (+1). When it is 135 deg C (120 deg C) or higher, decrease the value by 1 (-1). When the value of low temperature counter becomes +150, it is judged as Thermistor low temperature failure. The default and minimum value of low temperature detection counter is 0.

8) Frequency detection circuit error (230V models only)

When frequency measurement is not completed within 3255 msec after the completion of previous frequency measurement, it is judged as frequency detection circuit error.

● Processing after failure detection

If the Main Motor is in driving state when Fixing Assembly failure is detected, rotation of the motor is maintained for 300 msec after the machine moves in Fixing Assembly failure state. Then, drive systems (Main Motor system, Laser/Scanner system, high voltage system, and fixing system) are stopped immediately and the machine moves in failure state.

If the Main Motor is not in driving state, drive systems are stopped immediately and the machine moves in failure state.

● Other Functions

■ Throughput Down Control

This machine performs the throughput down control that extends the paper interval and lower the printing speed to prevent the edge of the fixing heater from overheating at continuous printing of small paper (the paper with narrow width) and to prevent the fixing heater unit from overheating at high-volume continuous printing.

An extended paper interval lowers the fixing heater temperature between the papers, preventing the edge of the roller of fixing assembly and the delivery unit from overheating. This control has the following 6 modes and the operation sequence differs depending on each modes.

Paper Type	Paper Size				
	Large-sized	Small-sized or Narrow	Long and Narrow		16K
	Length: 271 mm or more Width: 190 mm or more	Length: less than 271 mm (Width: less than 190 mm)	Length: less than 313 mm Width: less than 190 mm	Length: 313 mm or more Width: less than 190 mm	Length: 270 +/- 15 mm
Plain Paper	25 (Full speed) -> 12 (Half speed) *1	(2)	3 ppm (half speed)	1 ppm (half speed) *2	(5)
Plain Paper L	25 (Full speed) -> 12 (Half speed) *1	(2)	3 ppm (half speed)	1 ppm (half speed) *2	(5)
Heavy Paper	-	(1)	3 ppm (half speed)	1 ppm (half speed) *2	(6)
Rough Paper 1	-	(1)	3 ppm (half speed)	1 ppm (half speed) *2	(6)
Rough Paper 2	-	(1)	3 ppm (half speed)	1 ppm (half speed) *2	(6)
Label Paper	-	-	-	-	-
Transparency	-	-	-	-	-
Postcard	(4)	(4)	-	-	-
Envelope	-	(1)	-	-	-

T-2-9

*1 : When the number of fed paper reaches 270 after starting from Cold state, the speed changes from full speed to half speed, and the throughput changes from 25ppm to 12ppm. The number of fed paper at which the throughput changes from full speed to half speed may vary according to temperature control of the Fixing Assembly.

*2 : Measures against wrinkle and curl.

Number of Fed Sheets	(1)	(2)	(3)	(4)
	Half speed	Half speed	Half speed	Half speed
1 to 2	11 ppm	12 ppm	-	7 ppm
3	9 ppm	12 ppm	-	7 ppm
4 to 5	9 ppm	12 ppm	-	5 ppm
6 to 10	8 ppm	11 ppm	-	4 ppm
11 to 15	6 ppm	11 ppm	-	4 ppm
16 to 20	6 ppm	8 ppm	-	4 ppm
21 to 30	6 ppm	8 ppm	-	4 ppm
31 to 40	4 ppm	7 ppm	-	4 ppm
41 to 75	4 ppm	6 ppm	-	4 ppm
From 76	4 ppm	6 ppm	-	4 ppm

T-2-10

Number of Fed Sheets	(5)	(6)
	Full speed	Half speed
1 to 55	20 ppm	-
56 to 110	16 ppm	-
111 to 120	13 ppm	-
121 to 150	11 ppm	12 ppm
151 to 250	10 ppm	10 ppm
From 251	8 ppm	8 ppm

T-2-11

Service Works

■ At parts replacement

No work is required for this product at parts replacement.

■ Maintenance

No periodically replaced parts, durable parts or periodical service is set for this product.

■ Notes on service works

None.

Pickup And Feeding System

Overview

Overview

Duplex Feed

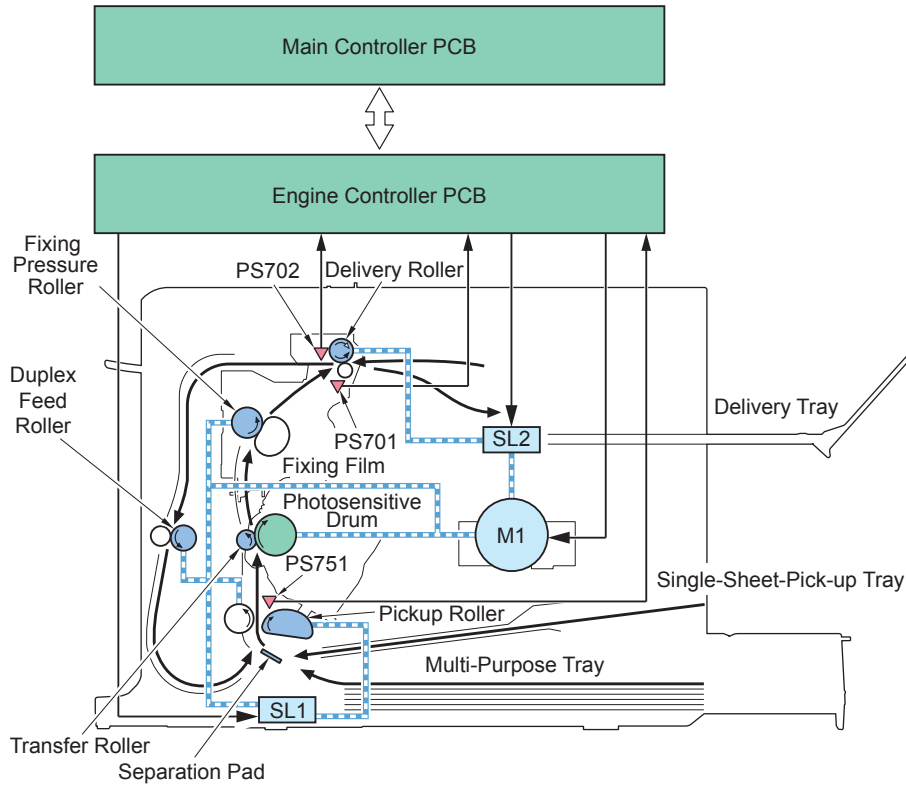

F-2-31

Single Feed

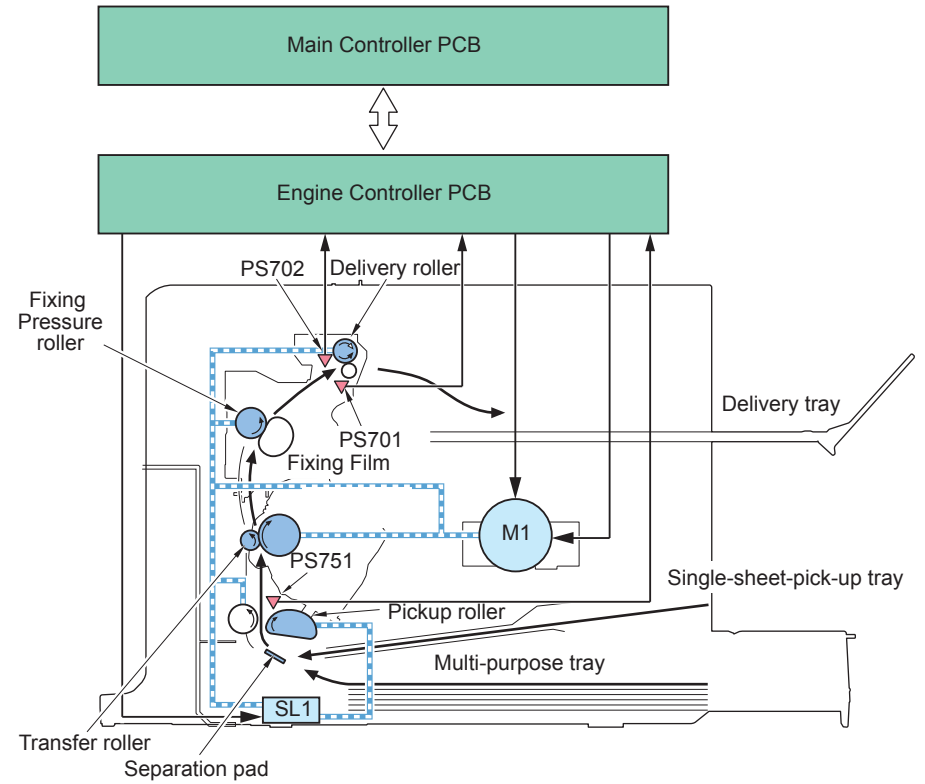

F-2-32

The pickup and feeding system executes pickup and feeding of papers and is composed of the main motor, solenoid, and rollers.

In this equipment, pickup from the pickup tray and manual feed tray is available. There is only a face-down delivery.

Papers set on the pickup tray and manual feed tray are fed by the same pickup roller. The papers are fed to the photosensitive drum, the transfer charging roller, the fixing sleeve unit, the pressure roller and then to delivery roller in this order; and then they are delivered to the delivery tray.

The feeding route of papers has three photointerrupters; the leading edge sensor (PS801), the fixing delivery sensor (PS701), the paper width sensor (PS702). They detect arrival and passing of papers.

If a paper does not reach or pass through each sensor within a specified time, the engine controller judges this status as jam and notices the jam occurrence to the main controller.

PS701: Fixing delivery sensor

PS702: Paper width sensor

PS801: Leading edge sensor

M1: Main motor

SL1: Pickup solenoid

SL2: Duplex Reverse solenoid

Detecting Jams

Jam Detection Outline

Overview

The following sensors are installed to detect absence/presence of papers and whether papers are correctly fed.

- Fixing delivery sensor (PS701)
- Paper width sensor (PS702)
- Leading edge sensor (PS751)

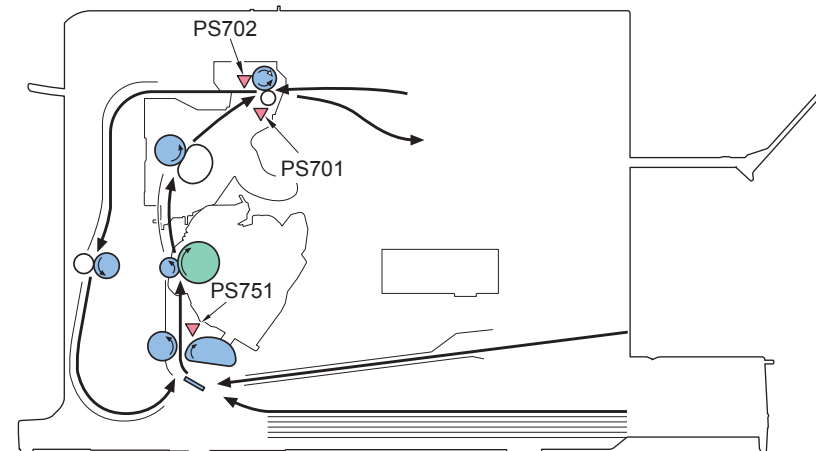

F-2-33

Whether jam occurs or not is judged according to whether a paper is absent/present on the sensor at the check timing that has been stored in the CPU of the engine controller.

When the engine controller judged that jam has occurred, print operation is stopped and jam occurrence is noticed to the main controller.

Delay Jams

Delivery Delay Jam

There are 3 types of delivery delay jam detections as follows:

- A. When there is no preceding paper
- B. When there is a preceding paper 1

In the case of narrow paper interval with the preceding paper

- C. When there is a preceding paper 2

In the case of wide paper interval with the preceding paper

A. When there is no preceding paper

If the delivery sensor (PS701) detects no paper from 700 (1400) ms to 1235 (2470) ms after detection by the TOP sensor (PS751), a delivery delay jam is determined.

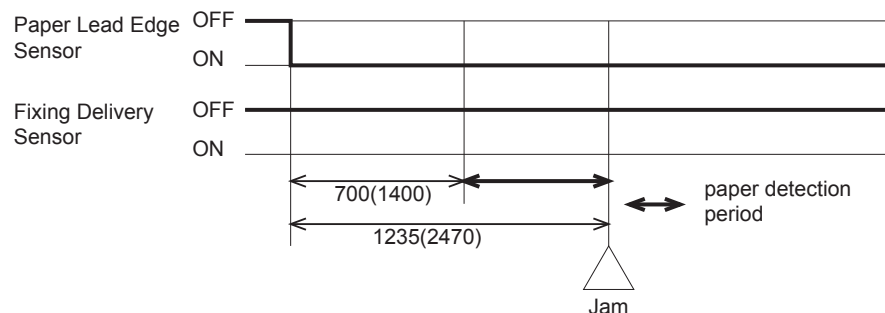

F-2-34

Note :

"700 (1400) ms" was calculated from the distance of 104.8 mm from the leading edge of the TOP sensor (PS751) to the fixing nip. "1235 (2470) ms" was calculated from the distance of 135.5 mm from the leading edge of the TOP sensor (PS751) to that of the delivery sensor (PS701) and the delivery delay jam margin of 50 mm. Since the distance from the fixing nip to the delivery sensor (PS701) is 30.7 mm, the length of wrapping from the leading edge will be 80.7 mm. Since one lap of the film is 18.2π (57.2) mm, the length of wrapping is more than one lap. Considering paper looping, sensor accuracy, and thick-paper delivery, however, the value cannot be made smaller.

B. When there is a preceding paper 1

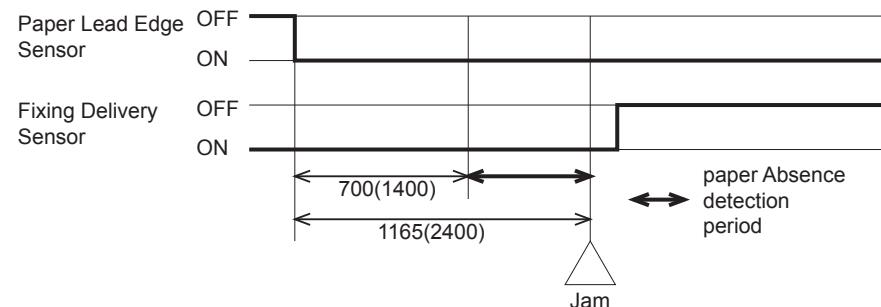

F-2-35

When there is preceding paper at the delivery sensor (PS701) 700 (1400) ms after paper detection by the TOP sensor (PS751) and the delivery sensor (PS701) does not detect the no-paper status until 1165 (2400) ms later, a delivery delay jam is determined.

C. When there is a preceding paper 2

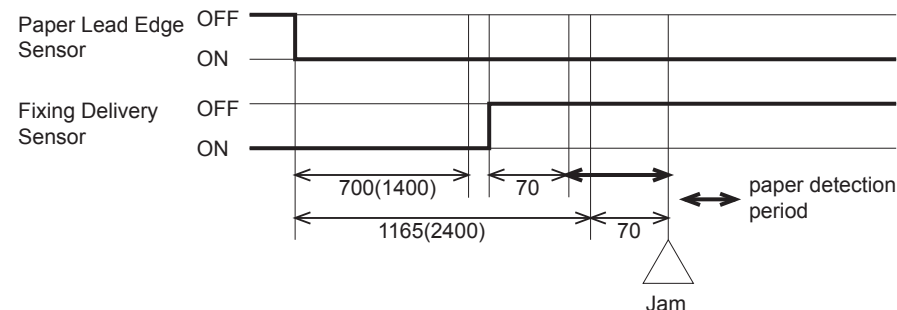

F-2-36

When there is preceding paper at the delivery sensor (PS701) 700 (1400) ms after paper detection by the TOP sensor (PS751) and the delivery sensor (PS701) detects the no-paper status by 1165 (2400) ms later, a delivery delay jam is determined only if the delivery sensor (PS701) does not detect paper in the period from 70 ms after no paper detection by the delivery sensor (PS701) until 1235 (2470) ms after paper detection by the TOP sensor (PS751).

Note :

"1165 (2400) ms" is the balance of subtracting a margin of 70 ms from the delivery delay jam detection end time of 1235 (2470) ms by considering chattering from the trailing edge of the preceding paper is at the delivery sensor until the leading edge of the next paper is detected.

Reversal Delay Jam

A reversal delay jam is determined when the Fixing Delivery Sensor (PS701) detects absence of paper at the time of 440 msec elapsed after the start of reversal operation.

Note :

The jam margin is 30 mm.

The sum of the distance from the reversing position to the leading edge detection position of the delivery sensor (PS701) plus the jam margin of 30 mm is equal to 520 ms at full speed and 1040 ms at half speed in terms of time. From the times, the delivery sensor (PS701) detection time of 30 ms is subtracted to calculate the jam judgment time.

Re-pickup Delay Jam

After the start of reversal, if the TOP sensor (PS751) does not detect paper within 2445 (4895) ms after paper detection by the delivery sensor (PS701), a re-pickup delay jam is determined.

Note :

The jam margin is 90 mm. This margin is set long because the paper path after reversal between paper detection by the delivery sensor (PS701) and that by the TOP sensor (PS751) is long, the paper path length depends on the paper quality, and the stop time at the registration shutter prepared on the path for skew correction depends on the delivered paper.

Delivery Delay Jam during auto delivery

A delivery delay jam is determined if the Paper Lead Edge Sensor (PS751) detects presence of paper and the Fixing Delivery Sensor (PS701) detects absence of paper at the time of 1115 msec elapsed after the start of auto delivery.

Note :

The auto delivery start timing is when the scanner stops.

Delivery Delay during cleaning

A delivery delay jam is determined if the Fixing Delivery Sensor (PS701) fails to detect presence of paper within 1235 msec since the Paper Lead Edge Sensor (PS751) detected presence of paper.

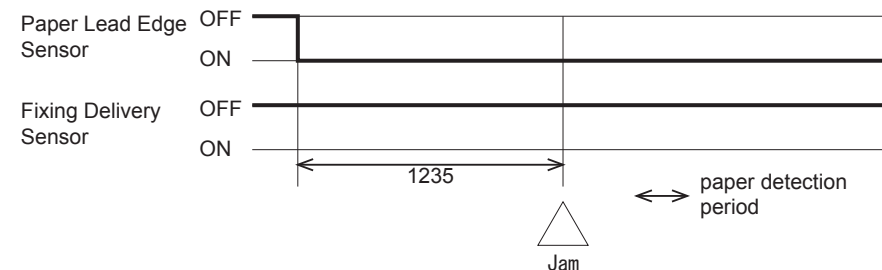

F-2-37

Multi-purpose tray pickup delay jam

When the multi-purpose tray (MPT) is specified as the paper source and paper is at the multi-purpose tray sensor, a feed delay jam is determined if the TOP sensor (PS751) does not detect fed paper with 1370 ms after the start of paper feed from the multi-purpose tray.

When the specified paper source is MPT, no jam status is output but the MPT no-paper status of the video interface.

■ Stationary Jams

● Pickup Stationary Jam

Without pre-feed, a feed stationary jam is determined if the TOP sensor (PS751) cannot detect the trailing edge of paper within 3960 (7920) ms after the leading edge is detected by the TOP sensor (PS751).

With pre-feed, a feed stationary jam is determined if the TOP sensor (PS751) cannot detect the trailing edge of paper within 4740 (9480) ms after the leading edge is detected by the TOP sensor (PS751).

Note :
"4740 ms" is the time equivalent of two LGL sheets. If LGL sheets are fed after A4-size standard continuous printing at pre-feed, the second LGL sheet may be fed as an A4-size standard sheet and therefore two LGL sheets may be fed almost with no break. To prevent this from stopping the machine by a jam, the feed stationary jam detection time during pre-feed is set to 4740 ms at full speed.

● Delivery Stationary Jam

The delivery sensor (PS701) is monitored for 265 (530) ms from 715 (1430) ms after no-paper detection by the TOP sensor (PS751), a delivery stationary jam is determined.

Note :
The margin is set to 20 mm because paper may spring up.

● Reversal Stationary Jam

After the start of reversal, if the delivery sensor (PS701) does not detect the no-paper status within 2570 (5140) ms after paper detection, a reverse stationary jam is determined.

Note :
This jam is determined if the delivery sensor (PS701) keeps detecting sensor for the time of delivering LEGAL + 30 mm.

● Pickup Stationary Jam during auto delivery

A pickup stationary jam is determined if the Paper Lead Edge Sensor (PS751) detects presence of paper at the time of 1115 msec elapsed after the start of auto delivery and then the Paper Lead Edge Sensor (PS751) detects presence of paper after the paper continued to be fed for 2730 msec.

● Delivery Stationary Jam during auto delivery

If there is no paper at the TOP sensor (PS751) 1235 (2470) ms after the start of auto delivery and there is paper at the delivery sensor (PS701) after further paper delivery of 980 (1965) ms, a delivery stationary jam is determined.

If there is paper at the TOP sensor (PS751) 1235 (2470) ms after the start of auto delivery and there is paper at the delivery sensor (PS701) after further paper delivery of 3075 (7410) ms, a delivery stationary jam is determined.

● Delivery Stationary Jam during cleaning

A delivery stationary jam is determined if the Fixing Delivery Sensor (PS701) fails to detect absence of paper within 2535 msec since the Main Motor started rotating after the cleaning step.

● Delivery Stationary Jam during warm-up rotation

If the delivery sensor (PS701) detects paper during warm-up rotation, a delivery stationary jam is determined.

Other Jams

Fixing Wrap Jam

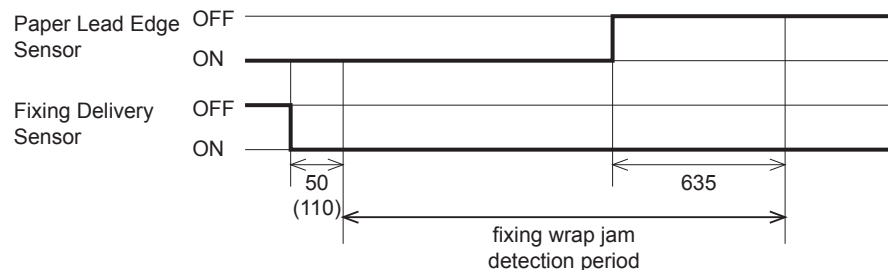

F-2-38

A fixing wrap jam is determined if the Fixing Delivery Sensor (PS701) detects absence of paper between the time of 50 msec after the Fixing Delivery Sensor (PS701) detected presence of paper and the time of 635 msec after the Paper Lead Edge Sensor (PS751) detected absence of paper.

Note :

The leading edge detection margin is 8 mm and the trailing edge detection margin is 20 mm. The leading edge margin is set to prevent the erroneous detection of a wrapping jam during chattering at paper entry. The trailing edge margin is set long because the detection time is not stable due to paper springing or other.

Initial Paper Jam during printing

An initial paper jam is determined if either the Fixing Delivery Sensor (PS701) or the Paper Width Sensor (PS702) detects presence of paper immediately before the Print Main Motor started its rotation.

Door Open Jam

A door open jam is determined when printing is interrupted due to the door open detection during printing while there is paper at the Paper Lead Edge Sensor (PS751) or the Fixing Delivery Sensor (PS702). The status value is retained if any jam has been already reported to the jam status.

Initial paper presence Jam during warm-up rotation

If either the delivery sensor (PS701) or the paper width sensor (PS702) detects paper at the start of warm-up rotation, an initial paper presence jam is determined.

No-paper detection during cleaning

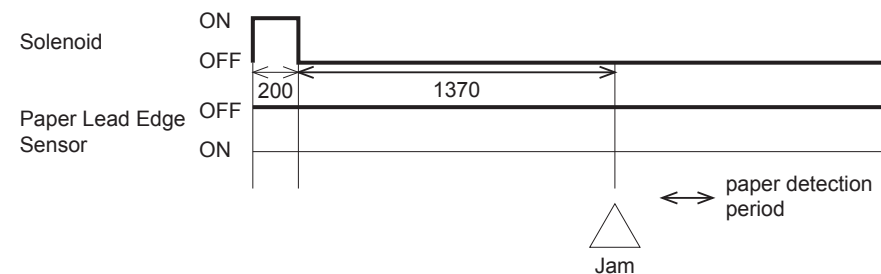

F-2-39

If the TOP sensor (PS751) does not detect paper for 1370 ms from 200 ms after the start of paper feed, the no-paper status is determined.

Service Works

■ At parts replacement

No work is required for this product at parts replacement.

■ Maintenance

No periodically replaced parts, durable parts or periodical service is set for this product.

■ Notes on service works

None.

External And Controls System

Power Supply

Power Supply

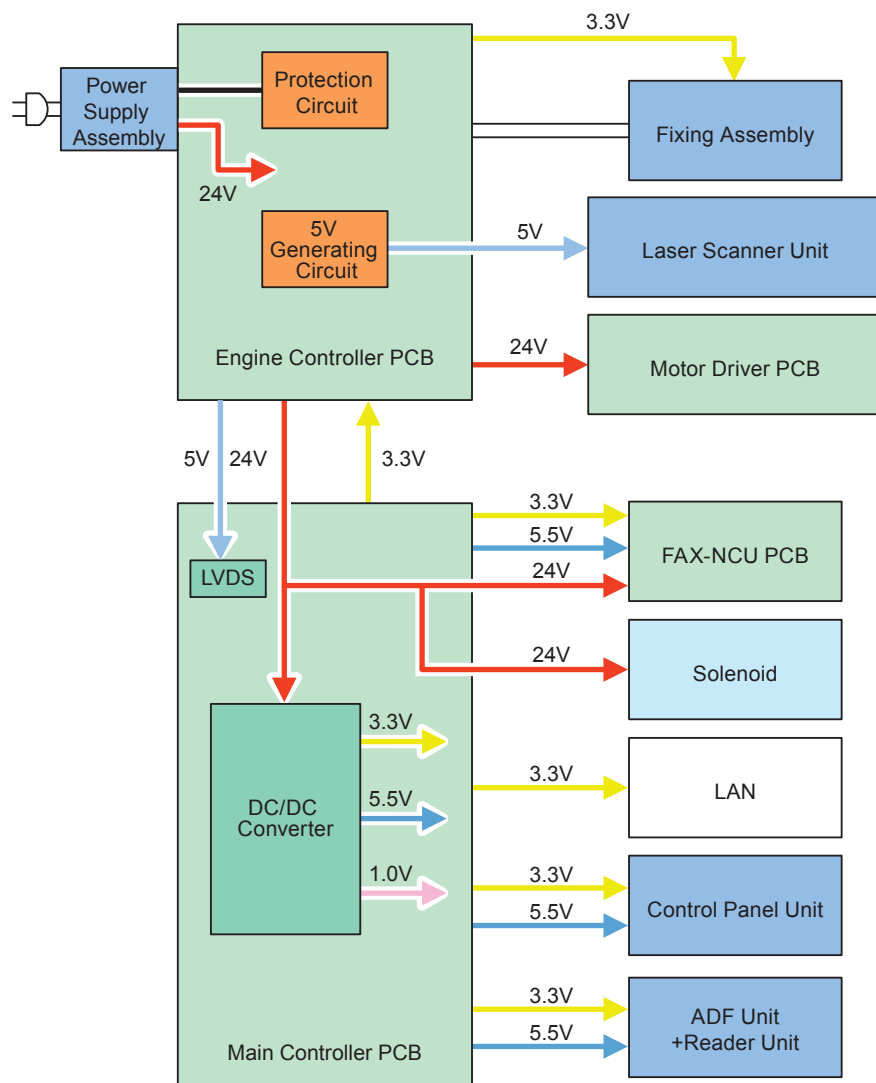

F-2-40

Protective Functions

Power protective function

Low voltage power circuit carries the overcurrent preventive function against and overvoltage preventive function that block the voltage output automatically to prevent the power circuit brokerage when the overcurrent or overvoltage occur due to load errors such as short circuit etc.

Thus, when the DC power cannot be output from the low voltage circuit, the protective function against overcurrent or overvoltage may be working. Since the secondary SW is used as the power SW, the power supply cord needs to be disconnected when fixing a trouble on the load side.

Also the circuit carries the 2 fuses (FU201, FU202) as a preventive function (see note 2). The fuses blow to block the power supply when overcurrent occurs in AC line.



When restoring the low voltage power after protective function is activated, leave it for 2 minutes plugging out before turning ON.

Safety function

The host machine equips the function of stopping 24V of fixing assembly and the high voltage power unit to avoid users and engineers from getting burned or electric shock.

When the cartridge door is opened, the interlock switch (SW501) is turned off and 24V supplied to fixing assembly and the high voltage power unit is shut.

Engine controller CPU determines the door open when each interlock switch is turned OFF.

Service Works

■ At parts replacement

No work is required for this product at parts replacement.

■ Maintenance

No periodically replaced parts, durable parts or periodical service is set for this product.

■ Notes on service works

None.



Periodical Services

- Periodically Replaced Parts
- Consumables
- Periodical Service

Periodically Replaced Parts

Periodically Replaced Parts

There is no periodically replaced part with this machine.

Consumables

Consumables

There is no consumable with this machine.

Periodical Service

Scheduled Servicing

There is no portion that requires schedule servicing in this equipment.

4

Disassembly/Assembly

- List of Parts
- Connectors Layout Drawing
- Original Exposure/Feed System (DADF Model)
- Original Exposure/Feed System (SADF Model)
- Original Exposure/Feed System (Copyboard Model)
- External Cover/Internal System (Duplex Model)
- Controller System (Duplex Model)
- Laser Exposure System (Duplex Model)
- Image Formation System (Duplex Model)
- Fixing System (Duplex Model)
- Pickup Feed System (Duplex Model)

4

Disassembly/Assembly

- External Cover/Internal System (Simplex Model)
- Controller System (Simplex Model)
- Laser Exposure System (Simplex Model)
- Image Formation System (Simplex Model)
- Fixing System (Simplex Model)
- Pickup Feed System (Simplex Model)

Outline

This chapter describes disassembling/assembling procedure of this equipment.

The service technician is to identify the cause of the failures according to "Chapter 6 Troubleshooting" and to replace the faulty parts by following the disassembling procedure. In addition, replace the consumable parts by following the same disassembling procedure.

Note the following precautions when working.

1. CAUTION: Be sure to disconnect the power plug before disassembling/assembling for safety.
2. When disassembling/assembling or transporting the machine, be sure to remove the cartridge beforehand as needed. However, when the cartridge is removed from the machine, be sure to put the Photosensitive Drum in a protective bag even in a short period of time to prevent the adverse effect of light.
3. When assembling, perform the disassembling procedure in reverse order unless otherwise specified.
4. When assembling, be sure to tighten the screws to their appropriate locations according to the screw types (length, diameter).
5. Do not run the machine with any parts removed as a general rule.
6. When handling the PCB, be sure to touch the metal part of the printer to ground yourself to prevent damaging the PCB by static electricity.
7. When replacing the part with the rating name plate, be sure to affix it to the new part.

List of Parts

External View

■ DADF Unit and Reader Unit

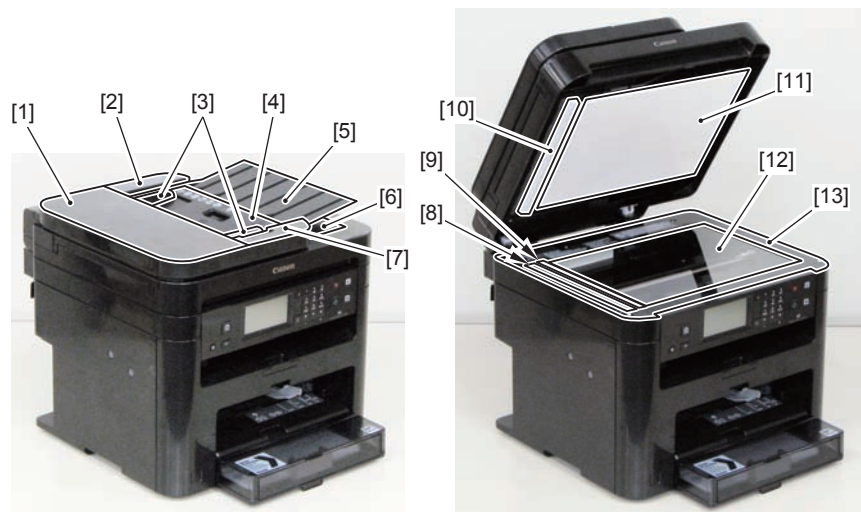

F-4-1

No.	Name	Reference	Remarks
[1]	DADF Upper Cover		-
[2]	DADF Rear Cover		-
[3]	Side Guide Plate		-
[4]	Original Feed Tray		-
[5]	Original Feed Auxiliary Tray		-
[6]	Original Delivery Tray		-
[7]	DADF Front Cover		-
[8]	Document Reading Glass		-
[9]	Copyboard Guide Holder		-
[10]	White Guide Plate		-
[11]	White Plate		-
[12]	Copyboard Glass	(Refer to page 4-44)	-
[13]	Copyboard Upper Cover		-

T-4-1

■ SADF Unit and Reader Unit

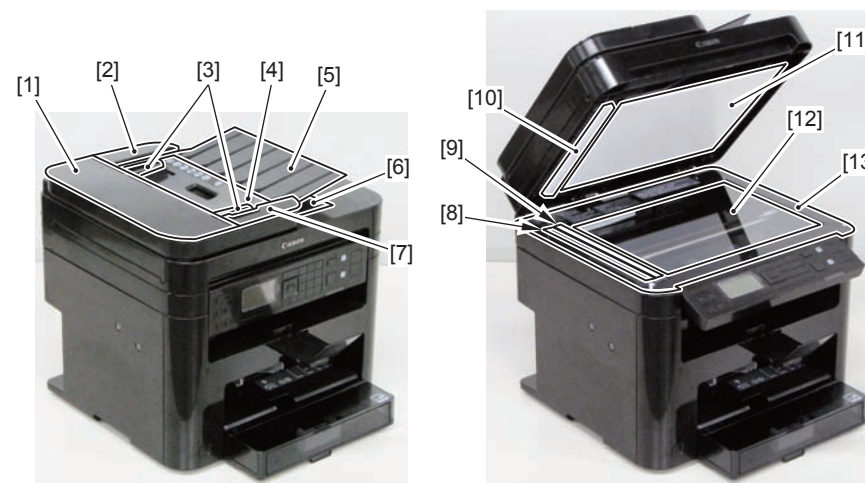

F-4-2

No.	Name	Reference	Remarks
[1]	SADF Upper Cover	(Refer to page 4-56)	-
[2]	SADF Rear Cover		-
[3]	Side Guide Plate		-
[4]	Original Feed Tray		-
[5]	Original Feed Auxiliary Tray		-
[6]	Original Delivery Tray		-
[7]	SADF Front Cover		-
[8]	Document Reading Glass		-
[9]	Copyboard Guide Holder		-
[10]	White Guide Plate		-
[11]	White Plate		-
[12]	Copyboard Glass	(Refer to page 4-68)	-
[13]	Copyboard Upper Cover		-

T-4-2

Copyboard Unit and Reader Unit



F-4-3

No.	Name	Reference	Remarks
[1]	Copyboard Cover	(Refer to page 4-75)	-
[2]	Copyboard Guide Holder		-
[3]	White Plate		-
[4]	Copyboard Glass	(Refer to page 4-78)	-
[5]	Copyboard Upper Cover		-

T-4-3

Duplex Printer Unit

Front Side

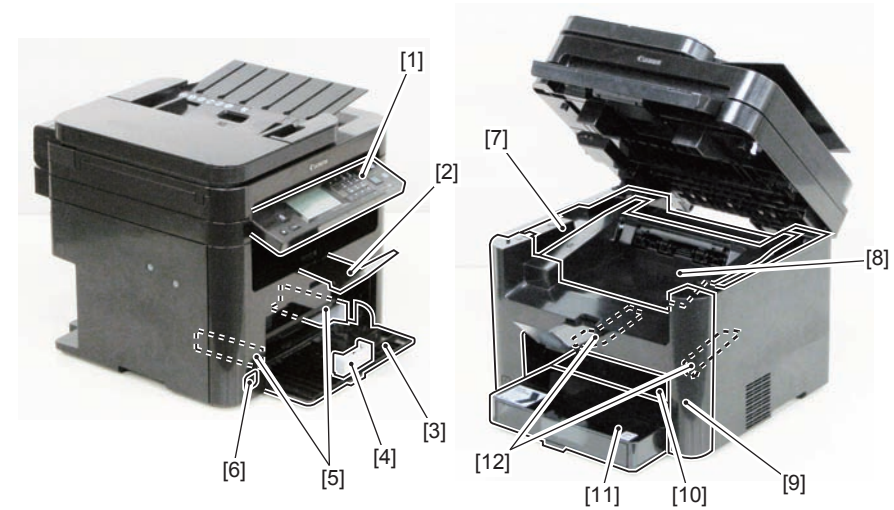

F-4-4

No.	Name	Reference	Remarks
[1]	Control Panel Unit	(Refer to page 4-93)	-
[2]	Delivery Auxiliary Tray		-
[3]	Pickup Tray		-
[4]	Trailing Edge Paper Guides		-
[5]	Pickup Tray Side Guide Plate		-
[6]	Power Switch		-
[7]	Upper Cover	(Refer to page 4-89)	-
[8]	Delivery Tray	(Refer to page 4-89)	-
[9]	Front Cover Unit	(Refer to page 4-89)	-
[10]	Multi-Purpose Tray		-
[11]	Tray Cover		-
[12]	Multi-Purpose Tray Side Guide Plate		-

T-4-4

Rear Side

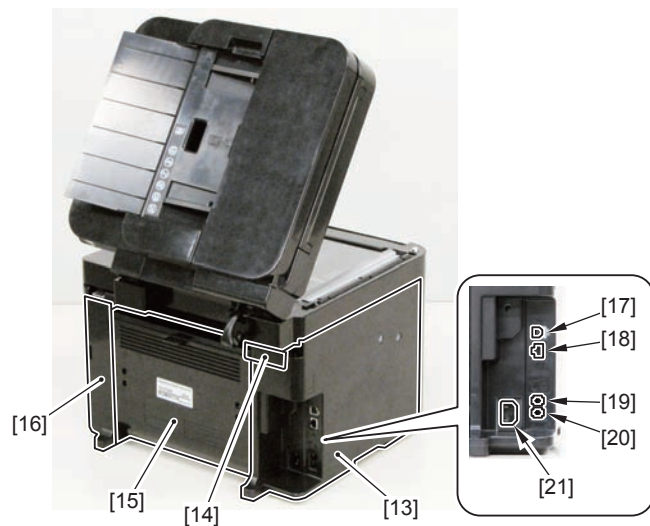

F-4-5

No.	Name	Reference	Remarks
[13]	Left Cover	(Refer to page 4-86)	-
[14]	Hinge Face Cover	-	-
[15]	Duplex Feed Guide Unit	(Refer to page 4-91)	-
[16]	Right Cover	(Refer to page 4-87)	-
[17]	USB Device Port	-	-
[18]	LAN Port	-	Model with NET
[19]	External Device Jack	-	Model with FAX
[20]	Telephone Line Jack	-	Model with FAX
[21]	Power Supply Cord Slot	-	-

T-4-5

Simplex Printer Unit

Front Side

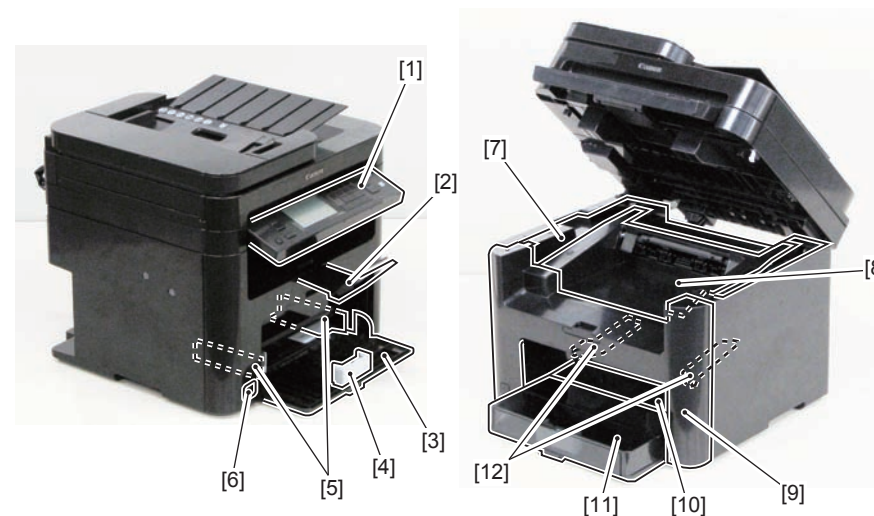

F-4-6

No.	Name	Reference	Remarks
[1]	Control Panel Unit	(Refer to page 4-151)	-
[2]	Delivery Auxiliary Tray	-	-
[3]	Pickup Tray	-	-
[4]	Trailing Edge Paper Guides	-	-
[5]	Pickup Tray Side Guide Plate	-	-
[6]	Power Switch	-	-
[7]	Upper Cover	(Refer to page 4-147)	-
[8]	Delivery Tray	(Refer to page 4-147)	-
[9]	Front Cover Unit	(Refer to page 4-147)	-
[10]	Multi-Purpose Tray	-	-
[11]	Tray Cover	-	-
[12]	Multi-Purpose Tray Side Guide Plate	-	-

T-4-6

Rear Side

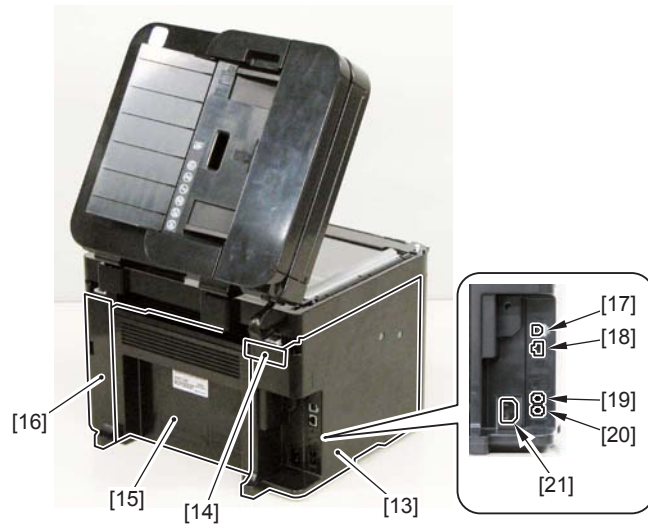

F-4-7

No.	Name	Reference	Remarks
[13]	Left Cover	(Refer to page 4-144)	-
[14]	Hinge Face Cover		-
[15]	Rear Cover	(Refer to page 4-149)	-
[16]	Right Cover	(Refer to page 4-145)	-
[17]	USB Device Port		-
[18]	LAN Port		Model with NET
[19]	External Device Jack		Model with FAX
[20]	Telephon Line Jack		Model with FAX
[21]	Power Supply Cord Slot		-

T-4-7

List of Main Unit

DADF Unit and Reader Unit

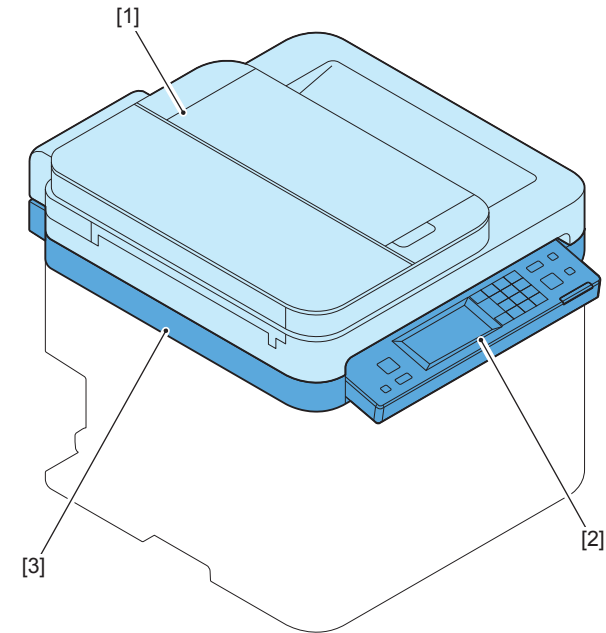

F-4-8

No.	Name	Reference	Remarks
[1]	DADF Unit	(Refer to page 4-30)	-
[2]	Control Panel Unit	(Refer to page 4-93)	-
[3]	Reader Unit	(Refer to page 4-30)	-

T-4-8

■ SADF Unit and Reader Unit

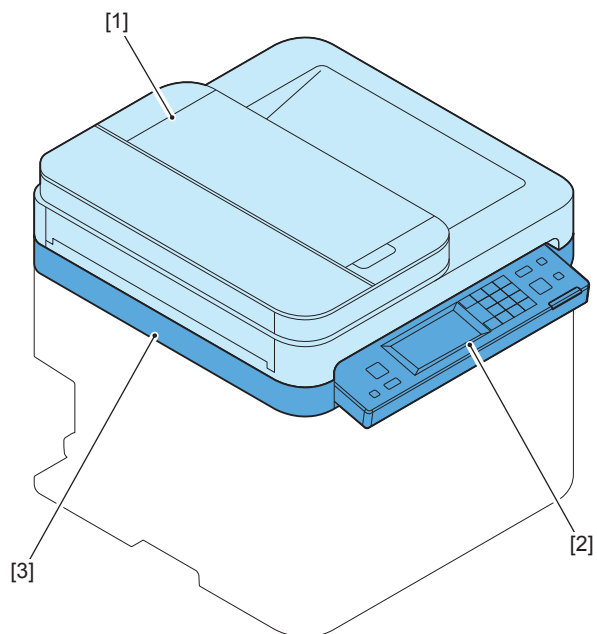

F-4-9

No.	Name	Reference	Remarks
[1]	SADF Unit	(Refer to page 4-54)	-
[2]	Control Panel Unit	(Refer to page 4-93)	Duplex Model
		(Refer to page 4-151)	Sinplex Model
[3]	Reader Unit	(Refer to page 4-54)	-

T-4-9

■ Copyboard Unit and Reader Unit

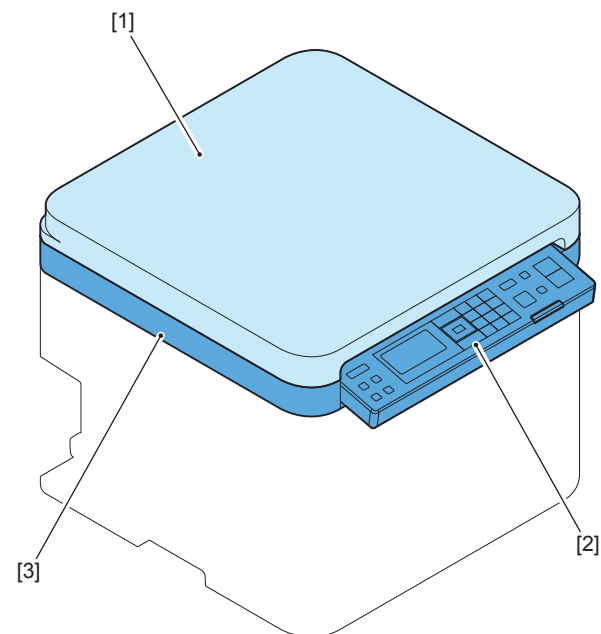

F-4-10

No.	Name	Reference	Remarks
[1]	Copyboard Cover	(Refer to page 4-75)	-
[2]	Control Panel Unit	(Refer to page 4-93)	Duplex Model
		(Refer to page 4-151)	Sinplex Model
[3]	Reader Unit	(Refer to page 4-76)	-

T-4-10

Duplex Printer Unit

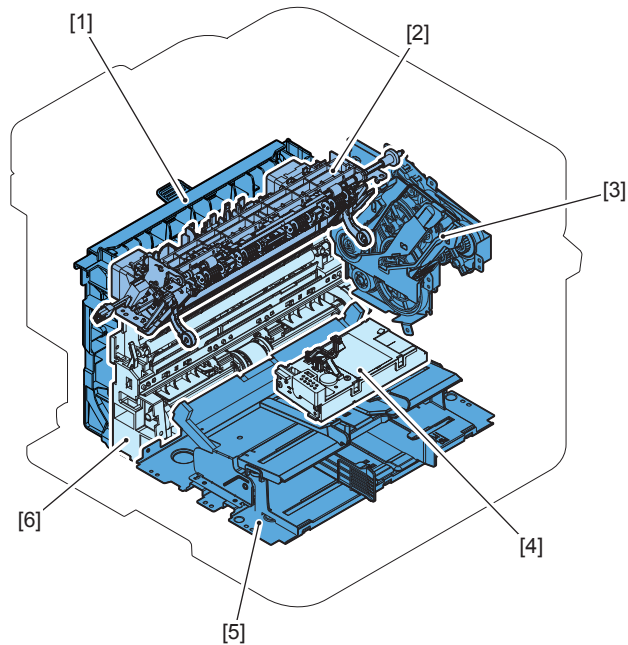

F-4-11

No.	Name	Reference	Remarks
[1]	Duplex Feed Guide Unit	(Refer to page 4-91)	-
[2]	Fixing Assembly	(Refer to page 4-122)	-
[3]	Main Drive Unit		-
[4]	Laser Scanner Unit	(Refer to page 4-118)	-
[5]	Pickup Tray Unit	(Refer to page 4-132)	-
[6]	Pickup Unit	(Refer to page 4-127)	-

T-4-11

Sinplex Printer Unit

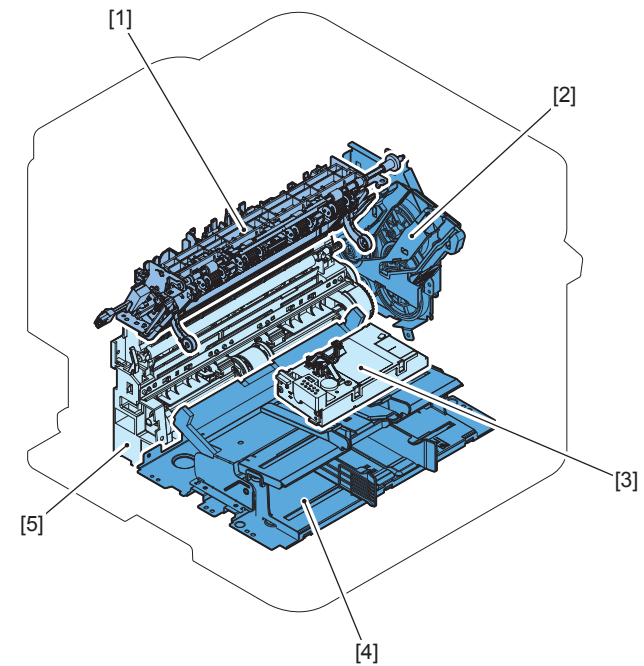

F-4-12

No.	Name	Reference	Remarks
[1]	Fixing Assembly	(Refer to page 4-122)	-
[2]	Main Drive Unit		-
[3]	Laser Scanner Unit	(Refer to page 4-171)	-
[4]	Pickup Tray Unit	(Refer to page 4-184)	-
[5]	Pickup Unit	(Refer to page 4-180)	-

T-4-12

Electrical Components

DADF Unit and Reader Unit

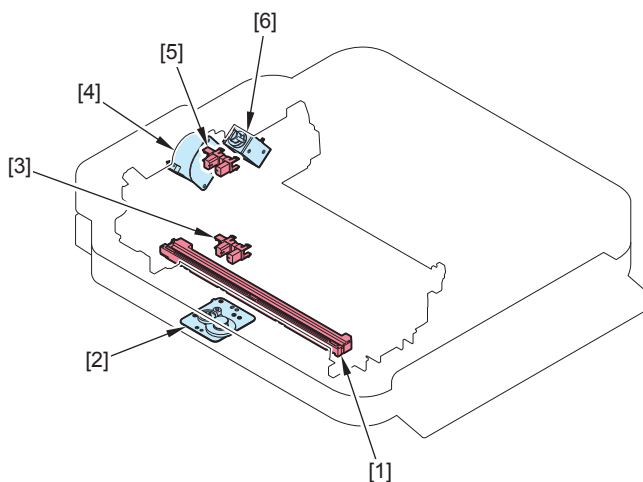

F-4-13

Key	E-No.	Name	Reference	Remarks
[1]	CIS	Contact Image Sensor	(Refer to page 4-46)	
[2]	M3	Flatbed Motor Unit	(Refer to page 4-48)	
[3]	PS2	DADF Original Sensor		
[4]	M4	DADF Motor Unit	(Refer to page 4-36)	
[5]	PS3	DADF Original Edge Sensor		
[6]	SL3	DADF Solenoid Unit	(Refer to page 4-38)	

T-4-13

SADF Unit and Reader Unit

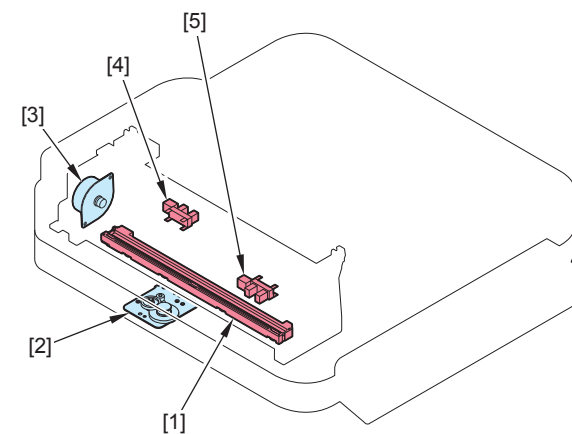

F-4-14

Key	E-No.	Name	Reference	Remarks
[1]	CIS	Contact Image Sensor	(Refer to page 4-70)	
[2]	M3	Flatbed Motor Unit	(Refer to page 4-72)	
[3]	M5	SADF Motor Unit	(Refer to page 4-61)	
[4]	PS5	SADF Original Edge Sensor		
[5]	PS4	SADF Original Sensor		

T-4-14

■ Copyboard Unit and Reader Unit

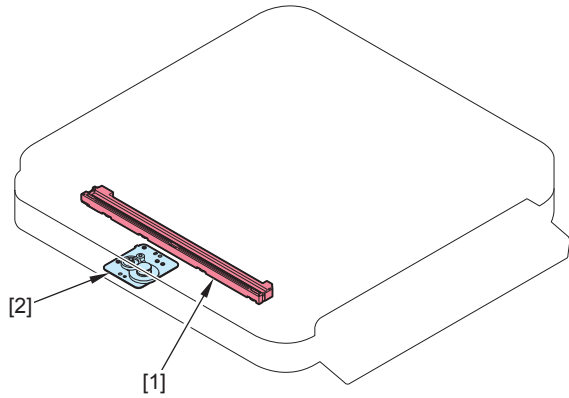

F-4-15

Key	E-No.	Name	Reference	Remarks
[1]	CIS	Contact Image Sensor	(Refer to page 4-80)	
[2]	M3	Flatbed Motor Unit	(Refer to page 4-82)	

T-4-15

■ Duplex Printer Unit

● Motor/Fan (Duplex Model)

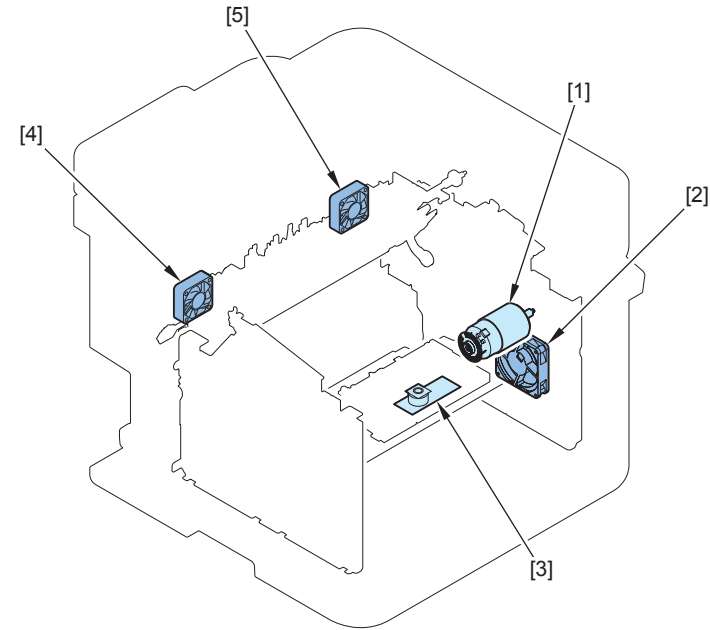

F-4-16

Key	E-No.	Name	Reference	Remarks
[1]	M1	Main Motor	(Refer to page 4-95)	
[2]	FM1	Main Fan	(Refer to page 4-97)	
[3]	M2	Laser Scanner Motor		
[4]	FM3	Edge Left Cooling Fan	(Refer to page 4-99)	
[5]	FM2	Edge Right Cooling Fan	(Refer to page 4-101)	

T-4-16

● Solenoid (Duplex Model)

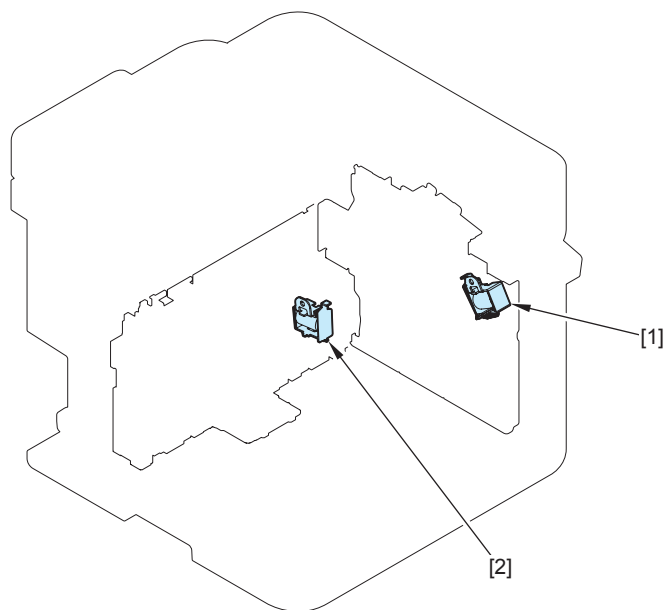

F-4-17

Key	E-No.	Name	Reference	Remarks
[1]	SL1	Duplex Solenoid	(Refer to page 4-141)	
[2]	SL2	Pickup Solenoid	(Refer to page 4-137)	

T-4-17

● Sensor (Duplex Model)

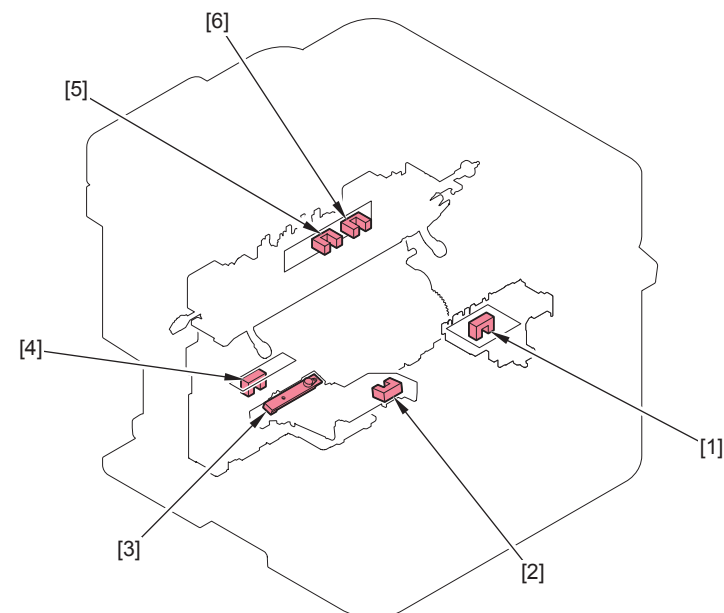

F-4-18

Key	E-No.	Name	Reference	Remarks
[1]	PS1151	Encoder Sensor		
[2]	PS1	Multi Pickup Sensor	(Refer to page 4-114)	
[3]	SR1	Toner Sensor	(Refer to page 4-114)	FAX Model
[4]	PS751	Paper Leading Edge Sensor	(Refer to page 4-108)	
[5]	PS702	Paper Width Sensor	(Refer to page 4-111)	
[6]	PS701	Fixing Delivery Sensor	(Refer to page 4-111)	

T-4-18

● Switch and Speaker (Duplex Model)

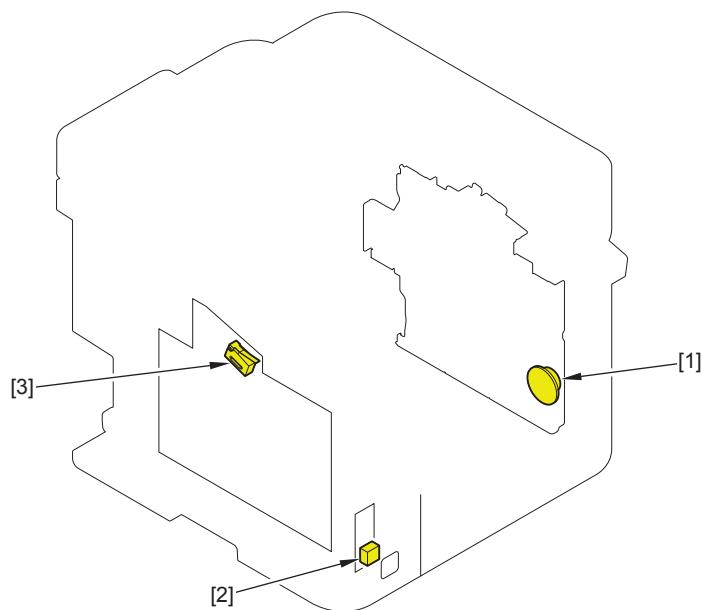

F-4-19

Key	E-No.	Name	Reference	Remarks
[1]	SP1	Speaker	(Refer to page 4-116)	FAX Model
[2]	UNIT3	Power Switch		
[3]	SW501	Door Switch		

T-4-19

● Heater/Thermoswitch/Thermistor (Duplex Model)

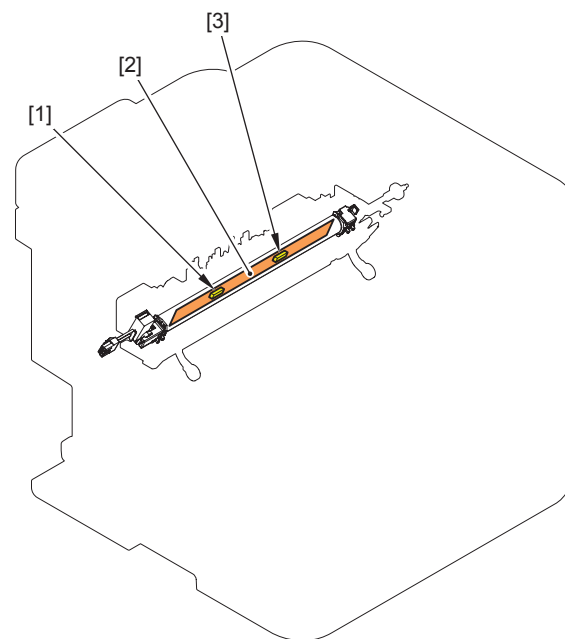

F-4-20

Key	E-No.	Name	Reference	Remarks
[1]	TP1	Thermoswitch		
[2]	H1	Fixing Heater		
[3]	TH1	Thermistor		

T-4-20

PCB (Duplex Model)

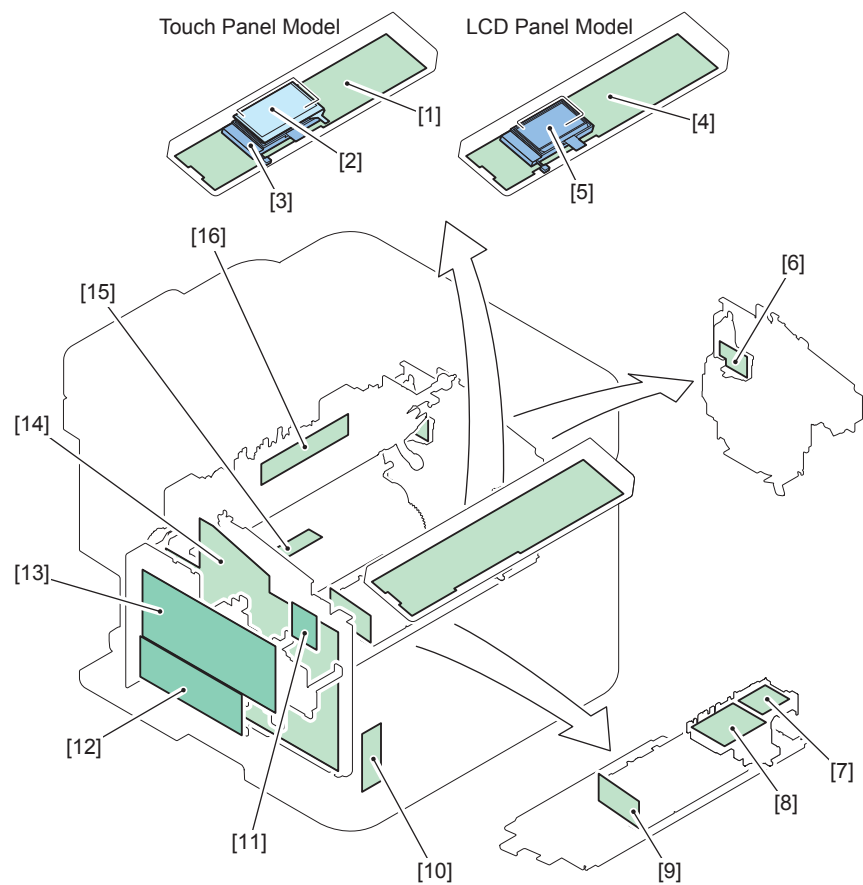

F-4-21

Key	E-No.	Name	Reference	Remarks
[1]	UNIT14	Control Panel PCB	(Refer to page 4-93)	Touch Panel Model
[2]	UNIT15	Touch Panel		Touch Panel Model
[3]	DSP1	Display		Touch Panel Model
[4]	UNIT13	Control Panel PCB		LCD Panel Model
[5]	DISP1	Display		LCD Panel Model
[6]	UNIT8	Bias		
[7]	UNIT5	Duplex Driver PCB		
[8]	UNIT4	Motor Driver PCB		
[9]	UNIT7	Laser Driver PCB		
[10]	UNIT3	Power Switch PCB		
[11]	UNIT13	Wireless LAN PCB	(Refer to page 4-108)	Wifi Model
[12]	UNIT16	FAX NCU PCB	(Refer to page 4-107)	FAX Model
[13]	UNIT11	Main controller PCB	(Refer to page 4-105)	
[14]	UNIT2	Engine Controller PCB	(Refer to page 4-102)	
[15]	UNIT10	Paper Leading Edge Sensor PCB	(Refer to page 4-108)	
[16]	UNIT9	Fixing Delivery/Paper Width Sensor PCB	(Refer to page 4-111)	

T-4-21

■ Sinplex Printer Unit

● Motor/Fan (Sinplex Model)

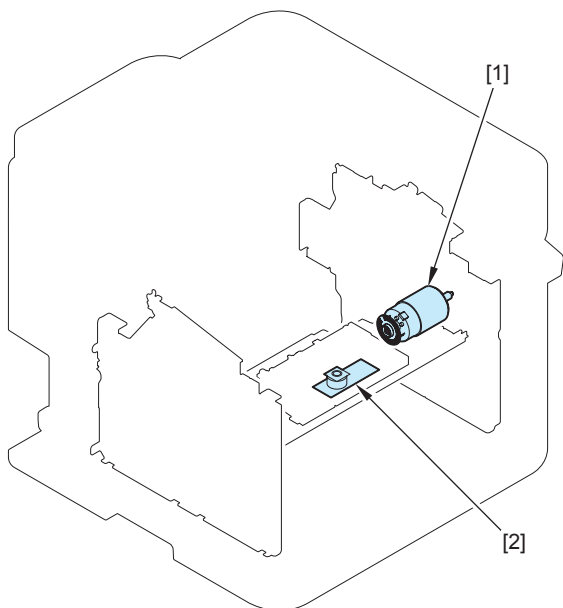

F-4-22

Key	E-No.	Name	Reference	Remarks
[1]	M1	Main Motor	(Refer to page 4-153)	
[2]	M2	Laser Scanner Motor		

T-4-22

● Solenoid (Sinplex Model)

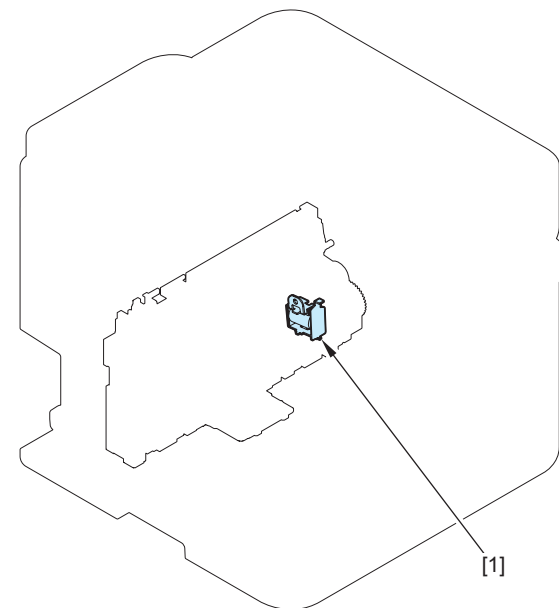

F-4-23

Key	E-No.	Name	Reference	Remarks
[1]	SL1	Pickup Solenoid	(Refer to page 4-190)	

T-4-23

● Sensor (Simplex Model)

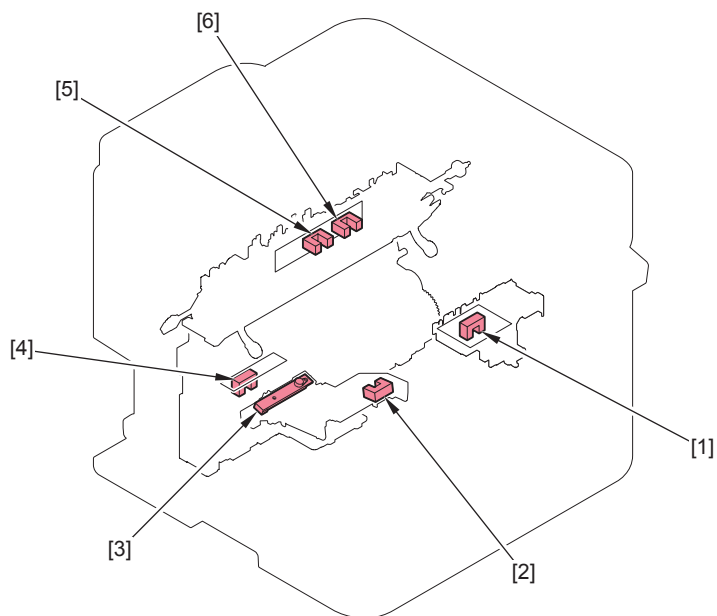

F-4-24

Key	E-No.	Name	Reference	Remarks
[1]	PS1151	Encoder Sensor		
[2]	PS1	Multi Pickup Sensor	(Refer to page 4-167)	
[3]	SR1	Toner Sensor	(Refer to page 4-167)	FAX Model
[4]	PS751	Paper Leading Edge Sensor	(Refer to page 4-162)	
[5]	PS702	Paper Width Sensor	(Refer to page 4-164)	
[6]	PS701	Fixing Delivery Sensor	(Refer to page 4-164)	

T-4-24

● Switch and Speaker (Simplex Model)

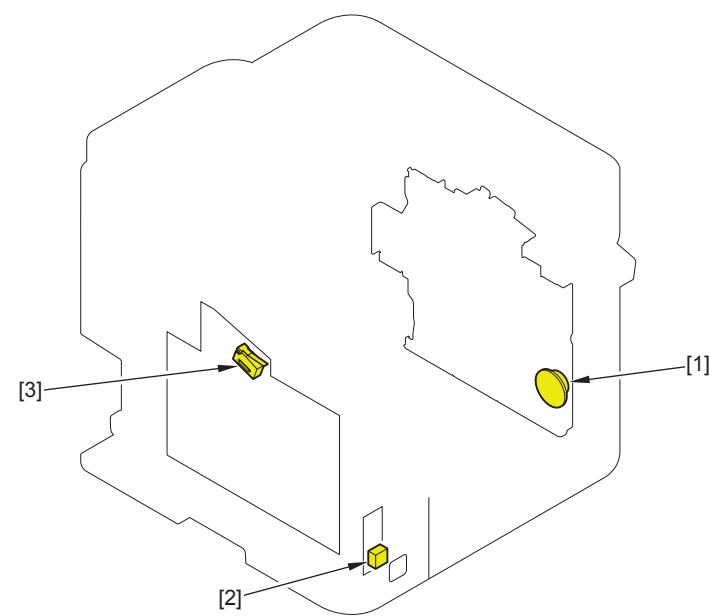

F-4-25

Key	E-No.	Name	Reference	Remarks
[1]	SP1	Speaker	(Refer to page 4-169)	FAX Model
[2]	UNIT3	Power Switch		
[3]	SW501	Door Switch		

T-4-25

● Heater/Thermoswitch/Thermistor (Sinplex Model)

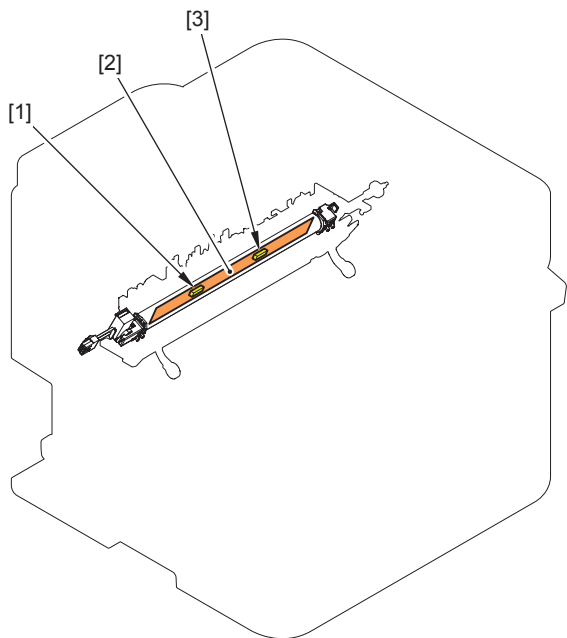

F-4-26

Key	E-No.	Name	Reference	Remarks
[1]	TP1	Thermoswitch		
[2]	H1	Fixing Heater		
[3]	TH1	Thermistor		

T-4-26

● PCB (Sinplex Model)

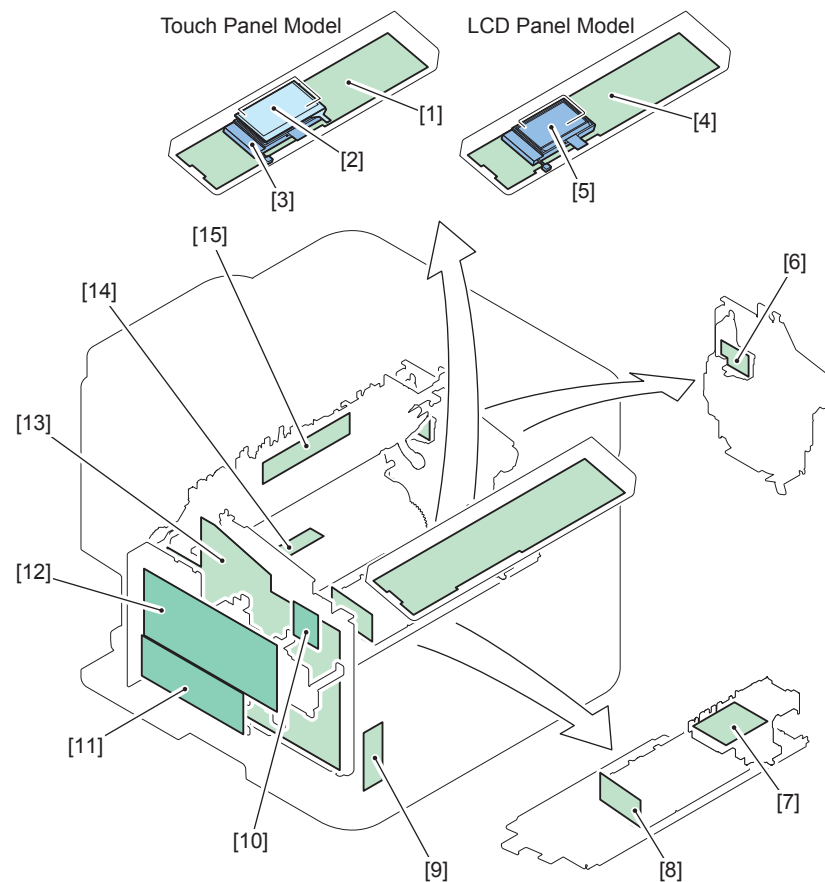

F-4-27

Key	E-No.	Name	Reference	Remarks
[1]	UNIT13	Control Panel PCB	(Refer to page 4-151)	Touch Panel Model
[2]	UNIT14	Touch Panel		Touch Panel Model
[3]	DSP1	Display		Touch Panel Model
[4]	UNIT13	Control Panel PCB		LCD Panel Model
[5]	DISP1	Display		LCD Panel Model
[6]	UNIT7	Bias		
[7]	UNIT4	Motor Driver PCB		
[8]	UNIT6	Laser Driver PCB		
[9]	UNIT3	Power Switch PCB		
[10]	UNIT12	WiFi Module PCB	(Refer to page 4-161)	Wifi Model
[11]	UNIT15	FAX-NCU PCB	(Refer to page 4-161)	FAX Model

Key	E-No.	Name	Reference	Remarks
[12]	UNIT10	Main Controller PCB	(Refer to page 4-159)	
[13]	UNIT2	Engine Controller PCB	(Refer to page 4-155)	
[14]	UNIT9	Paper Leading Edge Sensor PCB	(Refer to page 4-162)	
[15]	UNIT8	Fixing Delivery/Paper Width Sensor PCB	(Refer to page 4-164)	

T-4-27

Connectors Layout Drawing

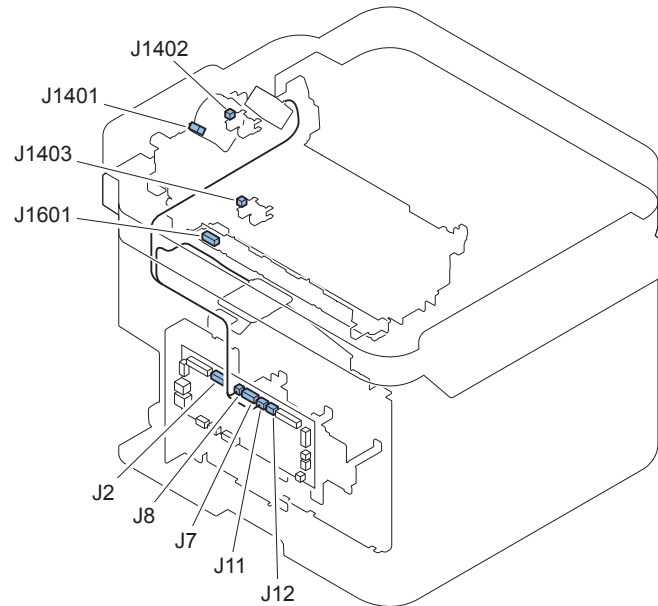
 DADF Unit and Reader Unit

F-4-28

J No.	Symbol	Name	Relay connector	J No.	Symbol	Name	Remarks
J2	UNIT11	Main controller PCB		J1601	CIS	CIS Sensor	
J7	UNIT11	Main controller PCB		J1402	PS2	Original Sensor	
J7	UNIT11	Main controller PCB		J1403	PS3	Original Edge Sensor	
J8	UNIT11	Main controller PCB		-	SL3	DADF Solenoid Unit	
J11	UNIT11	Main controller PCB		-	M3	Flatbed Motor Unit	
J12	UNIT11	Main controller PCB		J1401	M4	DADF Motor Unit	

T-4-28

SADF Unit and Reader Unit

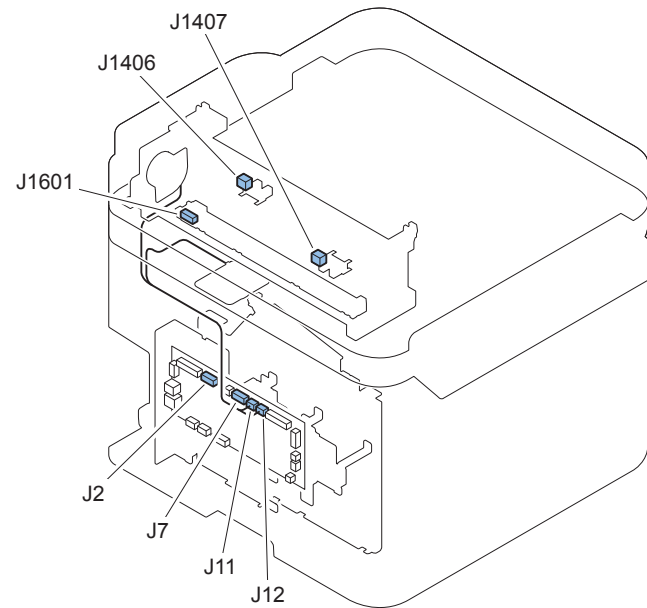

F-4-29

J No.	Symbol	Name	Relay connector	J No.	Symbol	Name	Remarks
J2	UNIT11	Main controller PCB		J1601	CIS	CIS Sensor	
J7	UNIT11	Main controller PCB		J1406	PS4	Original Sensor	
J7	UNIT11	Main controller PCB		J1407	PS5	Original Edge Sensor	
J11	UNIT11	Main controller PCB		-	M3	Flatbed Motor Unit	
J12	UNIT11	Main controller PCB		-	M5	SADF Motor Unit	

T-4-29

Copyboard Unit and Reader Unit

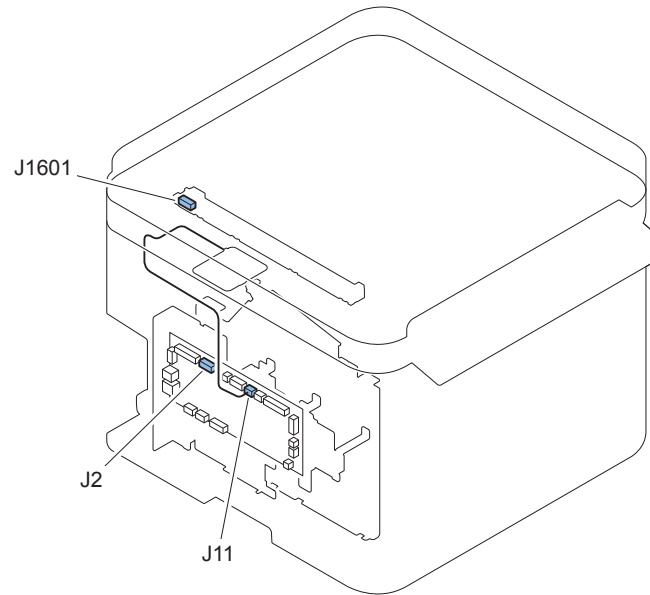

F-4-30

J No.	Symbol	Name	Relay connector	J No.	Symbol	Name	Remarks
J2	UNIT11	Main controller PCB		J1601	CIS	CIS Sensor	
J11	UNIT11	Main controller PCB		-	M3	Flatbed Motor Unit	

T-4-30

Duplex Printer Unit

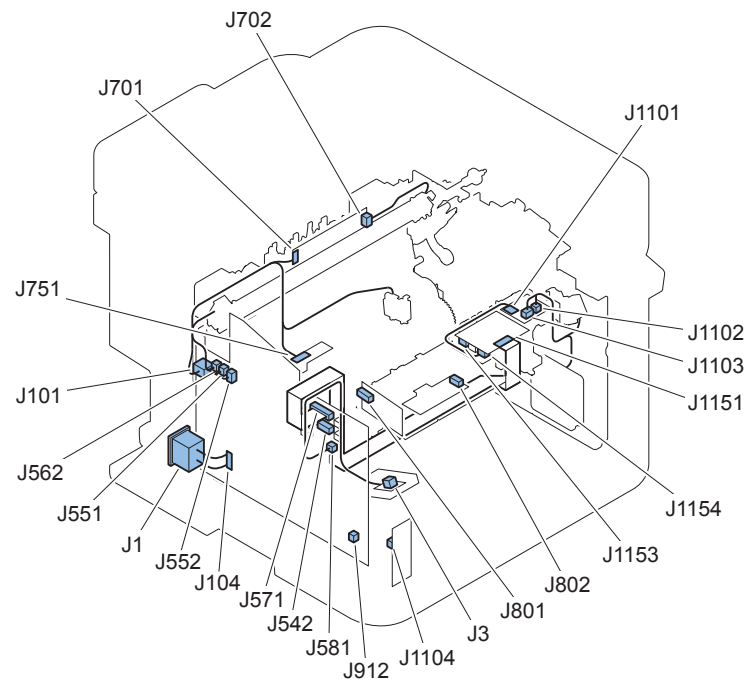

F-4-31

J No.	Symbol	Name	Relay connector	J No.	Symbol	Name	Remarks
J101	UNIT2	Engine Controller PCB		-	TP1	Thermoswitch	
J542	UNIT2	Engine Controller PCB		J801	UNIT7	Laser Driver PCB	
J551	UNIT2	Engine Controller PCB		-	UNIT10	Paper Leading Edge Sensor PCB	PS751
J552	UNIT2	Engine Controller PCB		-	UNIT9	Fixing Delivery/Paper Width Sensor PCB	PS701,PS702
J562	UNIT2	Engine Controller PCB		-	SL2	Pickup Solenoid	
J571	UNIT2	Engine Controller PCB		-	UNIT4	Motor Driver PCB	
J581	UNIT2	Engine Controller PCB		J3	-	TAG	
J912	UNIT2	Engine Controller PCB		J1104	UNIT3	Power Switch PCB	
-	UNIT2	Engine Controller PCB		J1	-	INLET	
J1153	UNIT4	Motor Driver PCB		J802	M2	Laser Scanner Unit	
J1154	UNIT4	Motor Driver PCB		-	UNIT5	Duplex Driver PCB	
J1102	UNIT5	Duplex Driver PCB		-	SL1	Duplex Solenoid	
J1103	UNIT5	Duplex Driver PCB		-	FM1	Main Fan	
-	TH1	Thermistor		J702	UNIT9	Fixing Delivery/Paper Width Sensor PCB	PS701,PS702

T-4-31

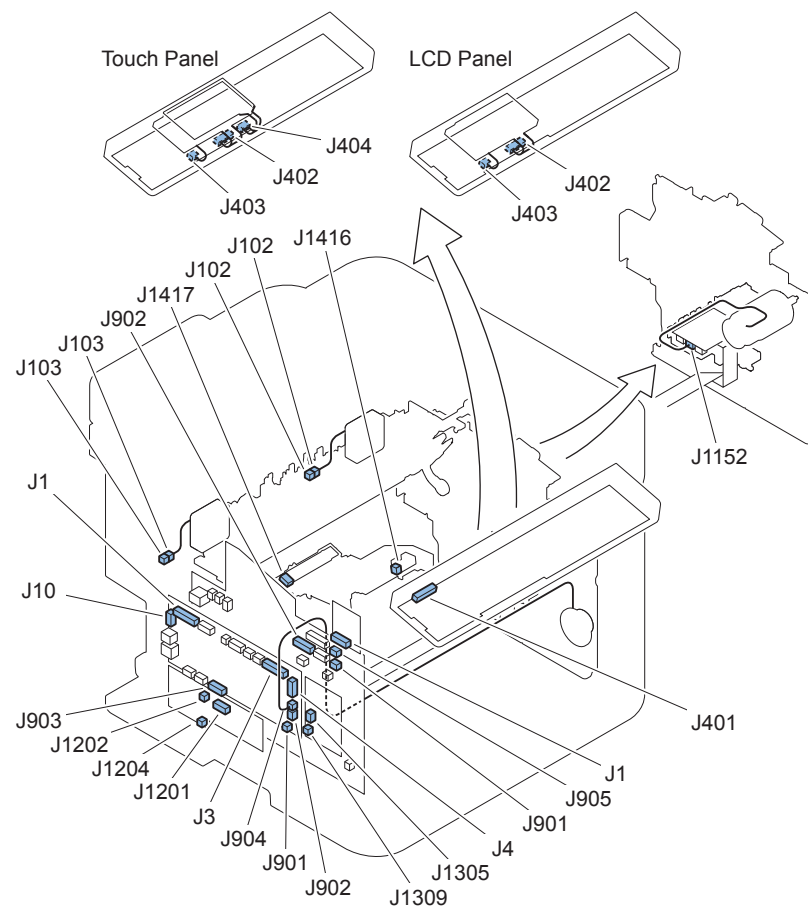

F-4-32

J No.	Symbol	Name	Relay connector	J No.	Symbol	Name	Remarks
J901	UNIT2	Engine Controller PCB		J1417	SR1	Toner Sensor	FAX Model
J905	UNIT2	Engine Controller PCB		J1416	PS1	Multi Pickup Sensor	
J1	UNIT11	Main controller PCB		J401	UNIT14	Control Panel PCB	
J3	UNIT11	Main controller PCB		J902	UNIT2	Engine Controller PCB	
J4	UNIT11	Main controller PCB		J1	UNIT13	Wireless LAN PCB	Wifi Model
J10	UNIT11	Main controller PCB	J103	J103	FM3	Edge Front Cooling Fan	
J10	UNIT11	Main controller PCB	J102	J102	FM2	Edge Rear Cooling Fan	
J901	UNIT11	Main controller PCB		J1204	UNIT16	FAX NCU PCB	FAX Model
J903	UNIT11	Main controller PCB		J1201	UNIT16	FAX NCU PCB	FAX Model
J904	UNIT11	Main controller PCB		-	SP1	Speaker	FAX Model
J1152	UNIT4	Motor Driver PCB		-	M1	Main Motor	
J402	UNIT14	Control Panel PCB		-	DISP1	Display	

J No.	Symbol	Name	Relay connector	J No.	Symbol	Name	Remarks
J403	UNIT14	Control Panel PCB		-	DISP1	Display	
J404	UNIT14	Control Panel PCB		-	UNIT15	Touch Panel	Touch Panel Model

T-4-32

Simplex Printer Unit

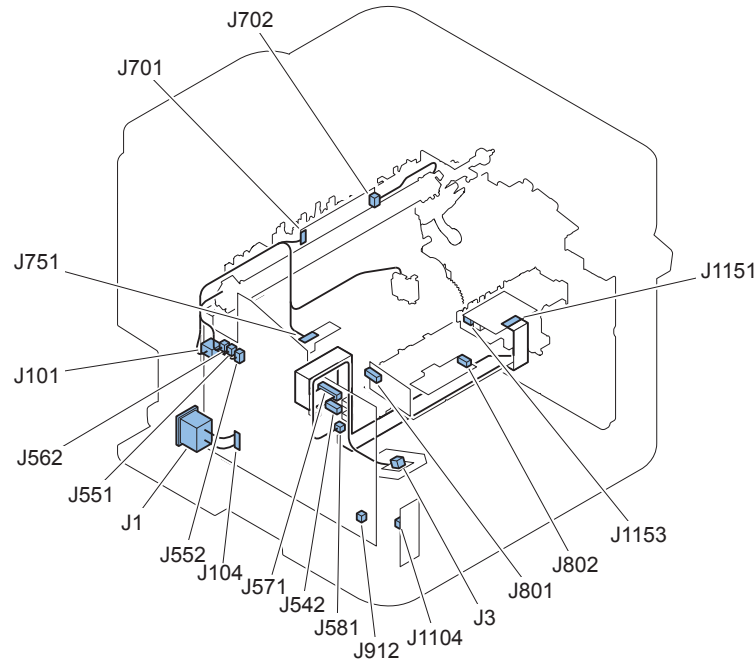

F-4-33

J No.	Symbol	Name	Relay connector	J No.	Symbol	Name	Remarks
J101	UNIT2	Engine Controller PCB		-	TP1	Thermoswitch	
J542	UNIT2	Engine Controller PCB		J801	UNIT7	Laser Driver PCB	
J551	UNIT2	Engine Controller PCB		J751	UNIT10	Paper Leading Edge Sensor PCB	PS751
J552	UNIT2	Engine Controller PCB		J701	UNIT9	Fixing Delivery/Paper Width Sensor PCB	PS701,PS702
J562	UNIT2	Engine Controller PCB		-	SL2	Pickup Solenoid	
J571	UNIT2	Engine Controller PCB		J1151	UNIT4	Motor Driver PCB	
J581	UNIT2	Engine Controller PCB		J3	-	TAG	
J912	UNIT2	Engine Controller PCB		J1104	UNIT3	Power Switch PCB	
J104	UNIT2	Engine Controller PCB		J1	-	INLET	
J1153	UNIT4	Motor Driver PCB		J802	M2	Laser Scanner Unit	
-	TH1	Thermistor		J702	UNIT9	Fixing Delivery/Paper Width Sensor PCB	PS701,PS702

T-4-33

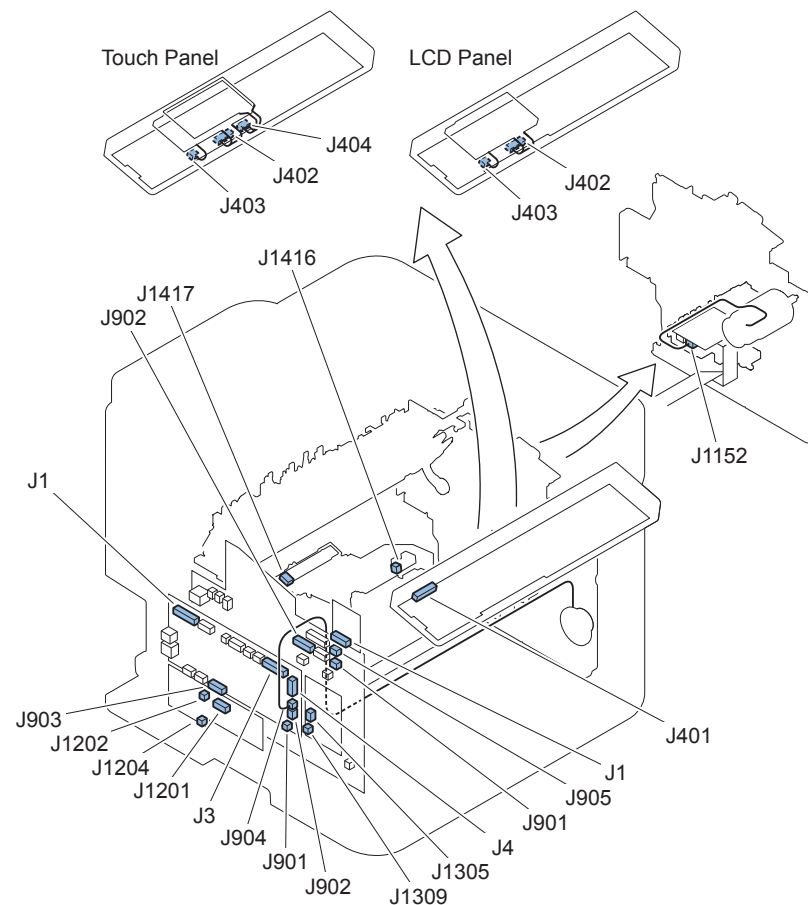

F-4-34

J No.	Symbol	Name	Relay connector	J No.	Symbol	Name	Remarks
J901	UNIT2	Engine Controller PCB		J1417	SR1	Toner Sensor	FAX Model
J905	UNIT2	Engine Controller PCB		J1416	PS1	Multi Pickup Sensor	
J1	UNIT10	Main controller PCB		J401	UNIT13	Control Panel PCB	
J3	UNIT10	Main controller PCB		J902	UNIT2	Engine Controller PCB	
J4	UNIT10	Main controller PCB		J1	UNIT12	Wireless LAN PCB	Wifi Model
J901	UNIT10	Main controller PCB		J1204	UNIT15	FAX NCU PCB	FAX Model
J903	UNIT10	Main controller PCB		J1201	UNIT15	FAX NCU PCB	FAX Model
J904	UNIT10	Main controller PCB		-	SP1	Speaker	FAX Model
J1152	UNIT4	Motor Driver PCB		-	M1	Main Motor	
J402	UNIT13	Control Panel PCB		-	DISP1	Display	
J403	UNIT13	Control Panel PCB		-	DISP1	Display	
J404	UNIT13	Control Panel PCB		-	UNIT13	Touch Panel	Touch Panel Model

T-4-34

Original Exposure/Feed System (DADF Model)

Layout Drawing

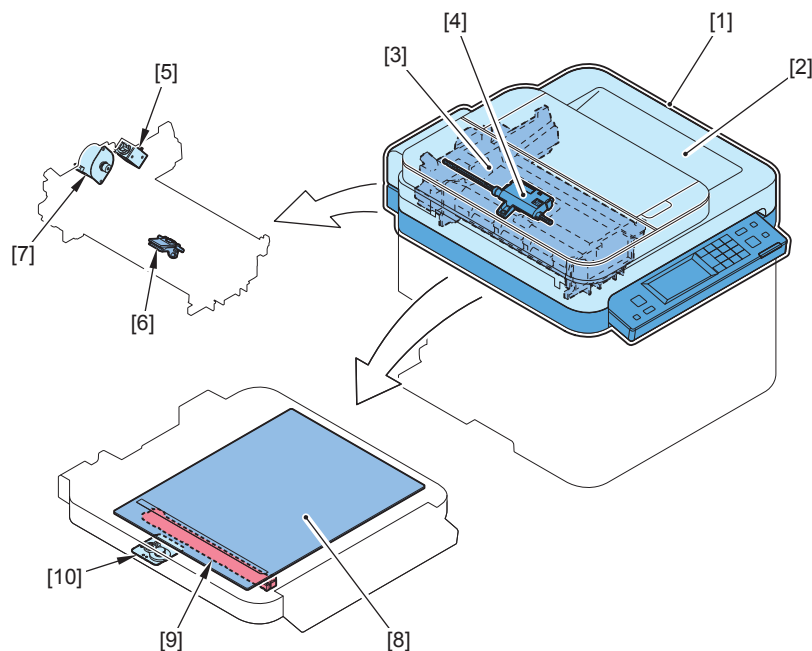

F-4-35

No.	Name	Reference	Remarks
[1]	DADF Unit and Reader Unit	(Refer to page 4-27)	
[2]	DADF Unit	(Refer to page 4-30)	
[3]	DADF Pickup Unit	(Refer to page 4-32)	
[4]	DADF Pickup Roller Unit	(Refer to page 4-39)	
[5]	DADF Solenoid Unit	(Refer to page 4-38)	
[6]	DADF Separation Pad	(Refer to page 4-41)	
[7]	DADF Motor Unit	(Refer to page 4-36)	
[8]	Copyboard Glass	(Refer to page 4-44)	
[9]	Contact Image Sensor	(Refer to page 4-46)	
[10]	Flatbed Motor Unit	(Refer to page 4-48)	

T-4-35

Removing the DADF Unit + Reader Unit



F-4-36

Preparation

1) Remove the Left Cover (Duplex Model) (Refer to page 4-86).

Procedure

- 1) Close the DADF Unit + Reader Unit [1].
- 2) Remove the Reader Harness Cover [2].
 - 2 Shafts [3]

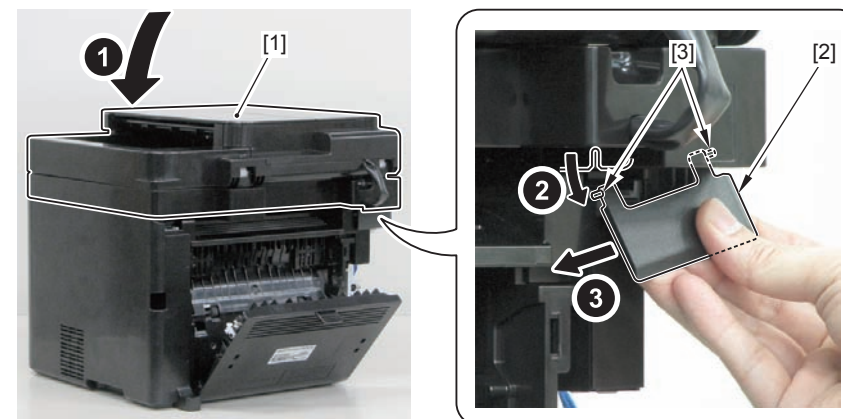

F-4-37

3) Disconnect the 2 terminals [1] and the 4 connectors [4] of the Grounding Wire, and free the Grounding Wire and the harness [5] from the Harness Guide [A].

- 1 Screw (black TP) [2]
- 1 Wire Saddle [3]

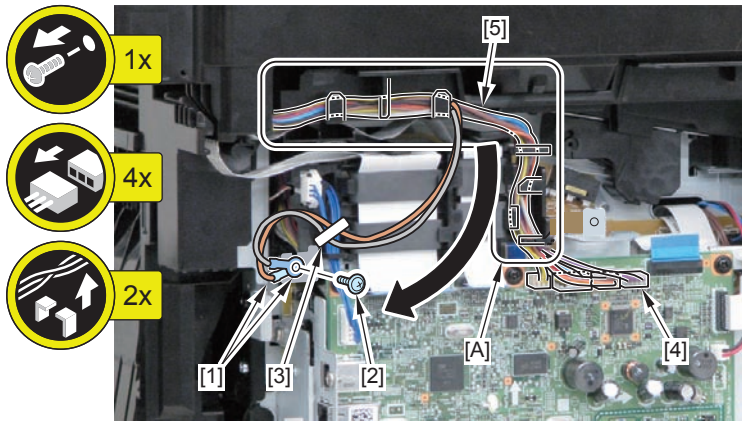

F-4-38

4) Free the 2 Flat Cables [1] from the Harness Guide [A].

- 4 Ferrite Cores [2]
- 4 Claws [3]

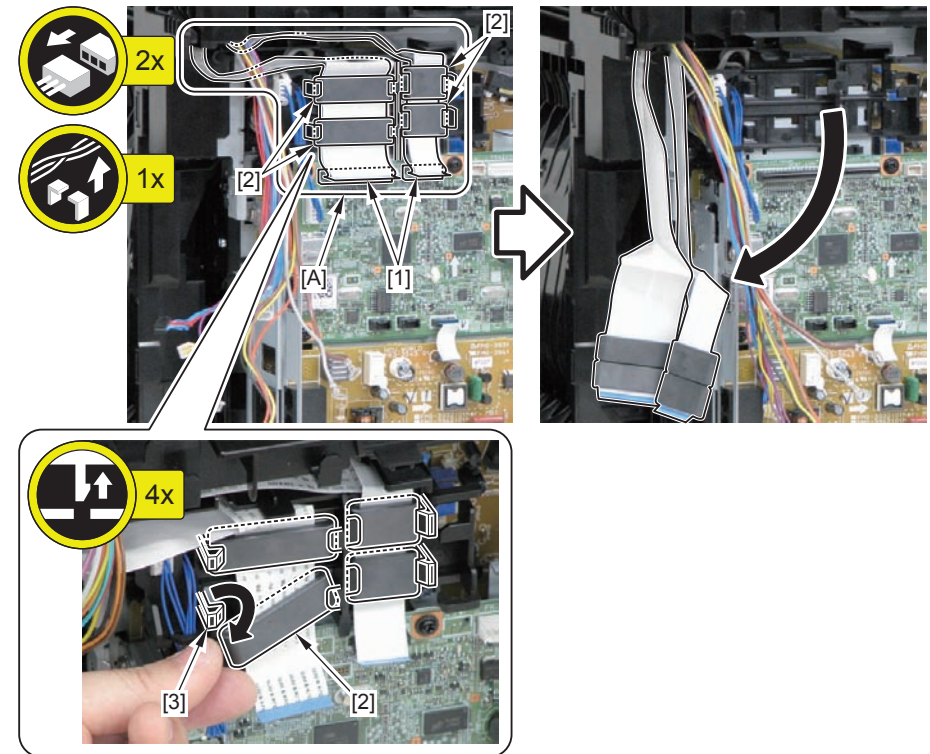

F-4-39

- 5) Open the DADF Unit + Reader Unit [1].
- 6) Remove the DADF Unit + Reader Unit [1].
 - 2 Claws [2]

CAUTION:

- Be sure to install/remove the unit carefully so as not to damage the Flat Cable [3] and harness [4] with the [A] part.

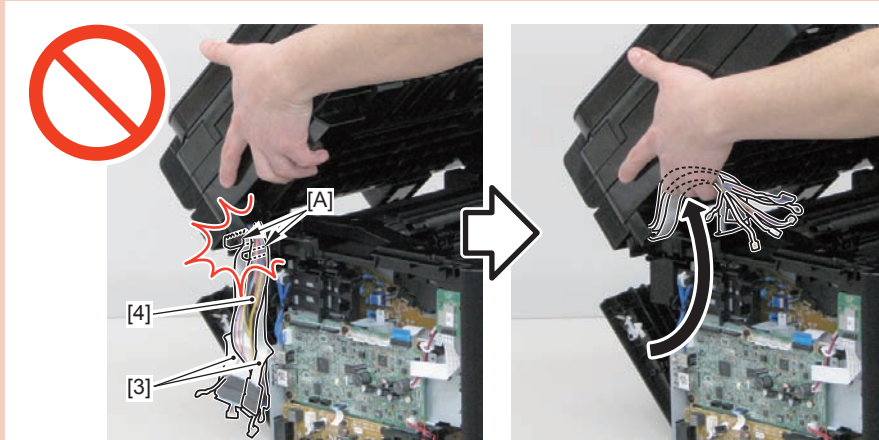

F-4-40

- Be sure to place the unit so as not to damage the Flat Cable [3] and harness [4].

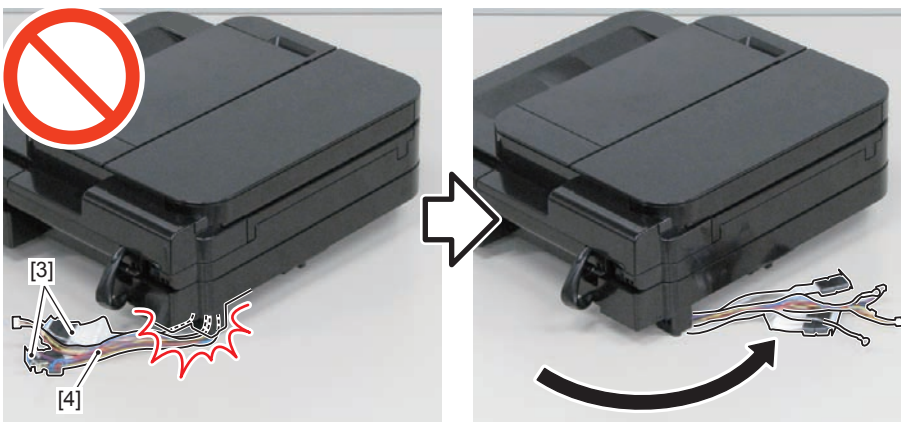

F-4-41

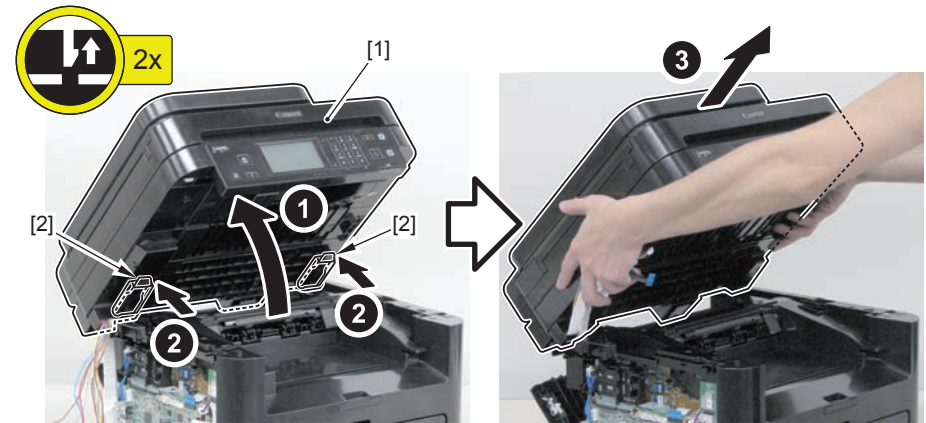

F-4-42

NOTE: How to assemble the DADF Unit + Reader Unit

Be sure to secure the 2 claws [1] of the Hinge Arm to the 2 hooks [2] of the Reader Unit.

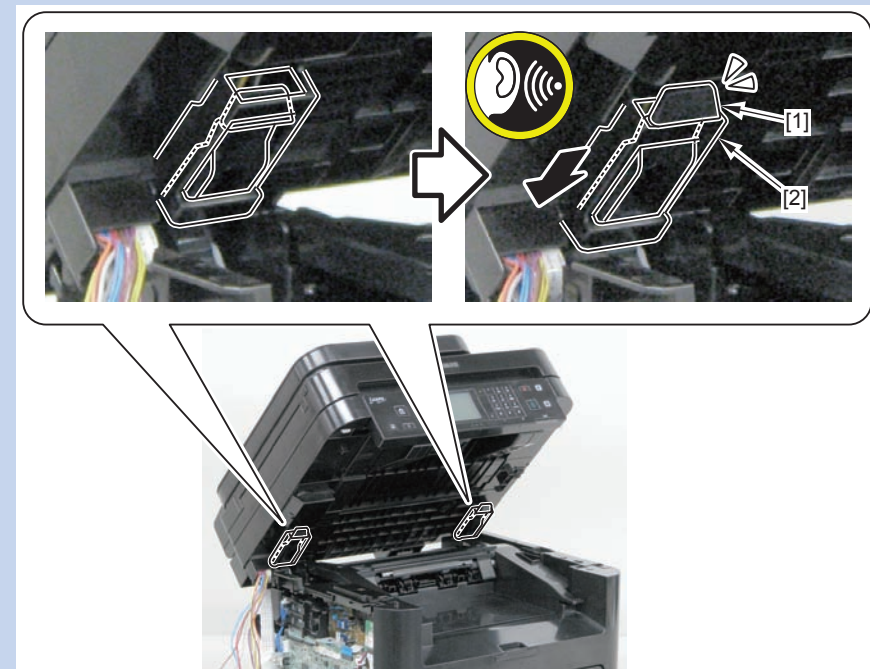

F-4-43

NOTE:

The following shows how to route the harness.

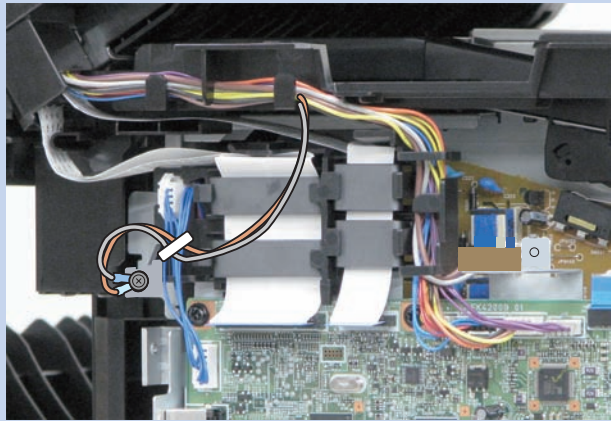

F-4-44

Disconnecting the DADF Unit + Reader Unit



F-4-45

Preparation

- 1) Remove the Left Cover (Duplex Model) (Refer to page 4-86).
- 2) Remove the DADF Unit + Reader Unit (Refer to page 4-27).

Procedure

CAUTION:

Do not damage the White Sheet [1] and White Guide Plate [2].

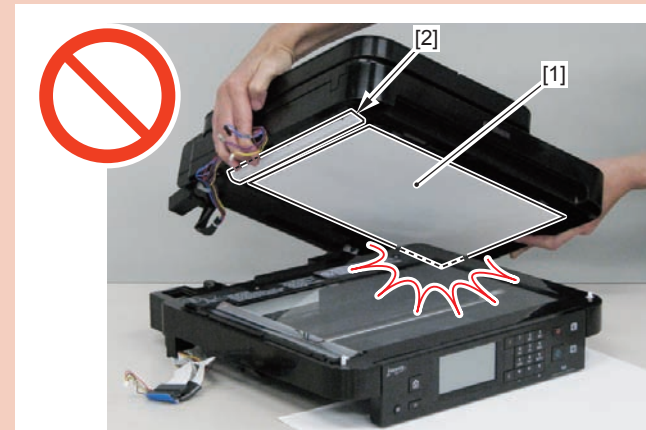

F-4-46

1) Change the orientation of the Control Panel Unit [1] so that it is facing down.

CAUTION:

Be sure to put a piece of paper [2] and place the Control Panel Unit [1] on it carefully so as not to damage it.

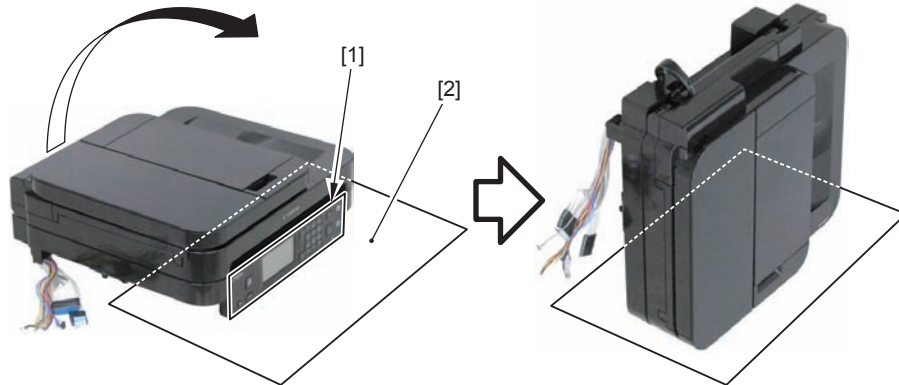

F-4-47

2) Remove the Harness Cover [1].

- 4 Claws [2]

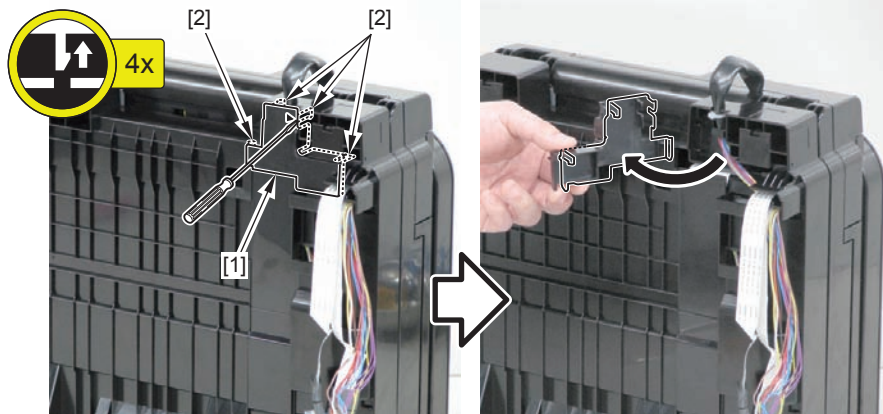

F-4-48

3) Free the harness [1] from the guide [A].

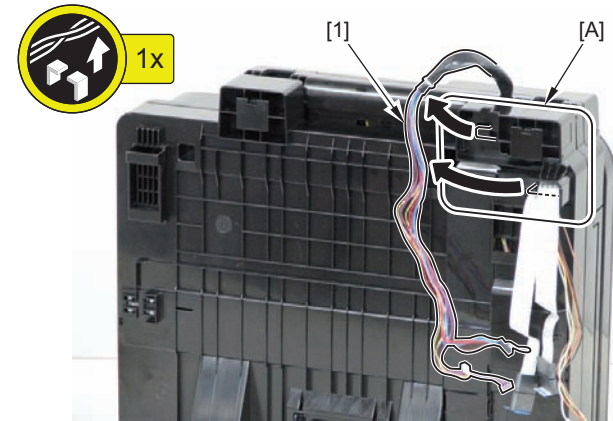

F-4-49

NOTE: How to Assemble the Harness Cover

As for the guide [A], be sure to install the Harness Cover after routing the harness [2] on the back side of the Flat Cable [1].

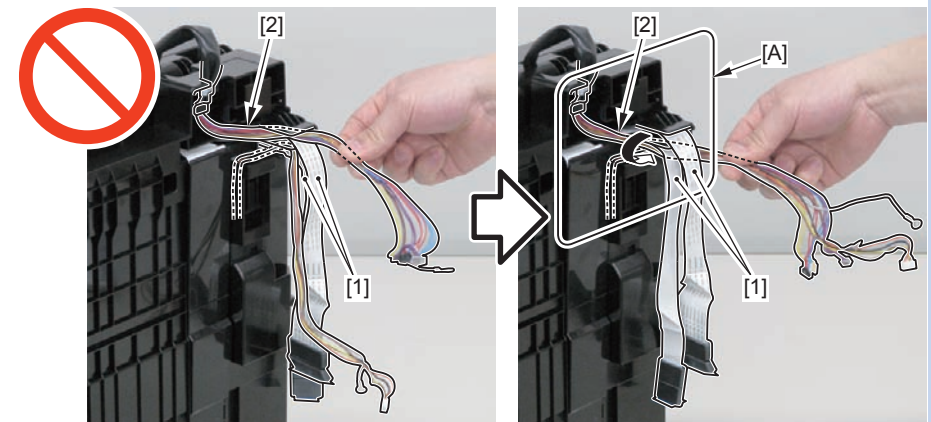

F-4-50

- 4) Change the orientation of the Reader Unit so that its bottom surface [1] is facing down.
 5) Release the lock [2] on the lower left front side of the Reader Unit, and open the DADF Unit [3].

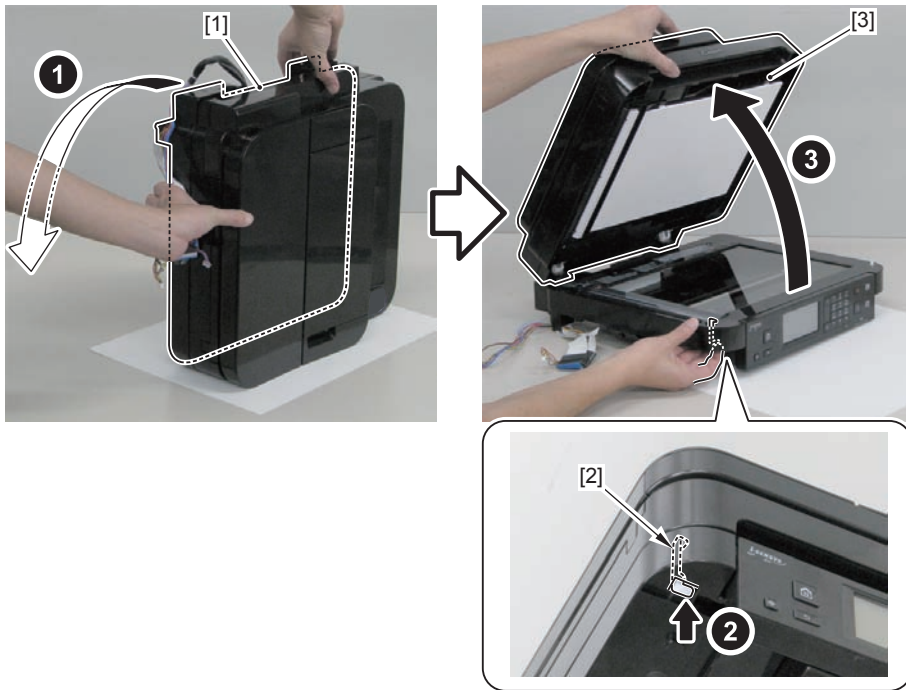

F-4-51

- 6) Separate the DADF Unit [1] and the Reader Unit [2].



F-4-52

Removing the DADF Pickup Unit

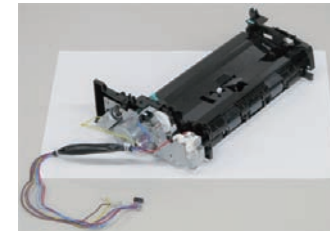

F-4-53

Preparation

- 1) Remove the Left Cover (Duplex Model) (Refer to page 4-86).
- 2) Remove the DADF Unit + Reader Unit (Refer to page 4-27).
- 3) Disconnecting the DADF Unit + Reader Unit (Refer to page 4-30).

Procedure

CAUTION:

Do not damage the White Guide Plate [1].

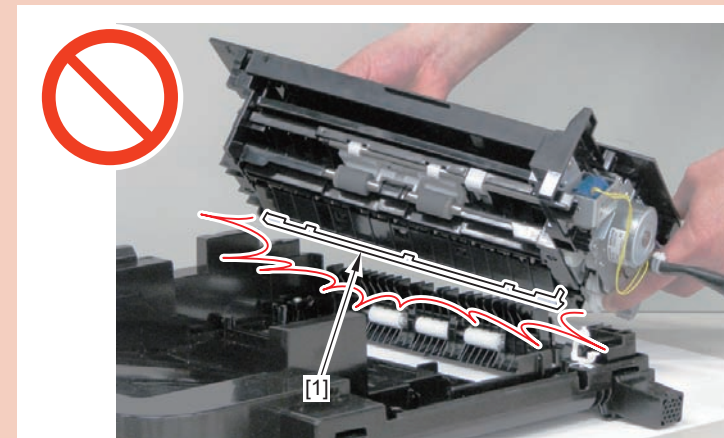

F-4-54

1) Open the DADF Pickup Auxiliary Tray [1] and DADF Upper Cover Unit [2].

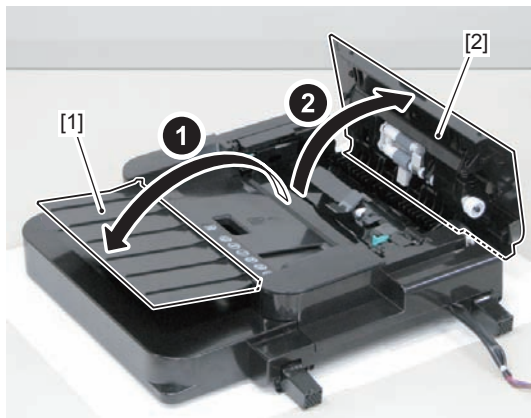

F-4-55

2) Close the DADF Pickup Auxiliary Tray, and remove the DADF Pickup Tray Unit [1].

- 1 Claw [2]

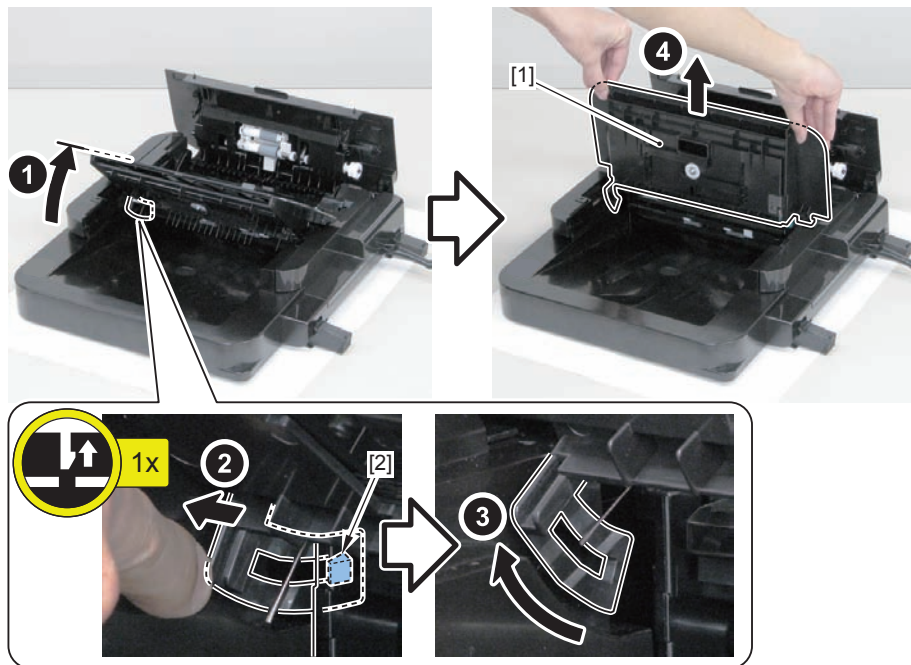

F-4-56

3) Remove the DADF Rear Cover [1].

- 1 Boss [2]
- 3 Hooks [3]

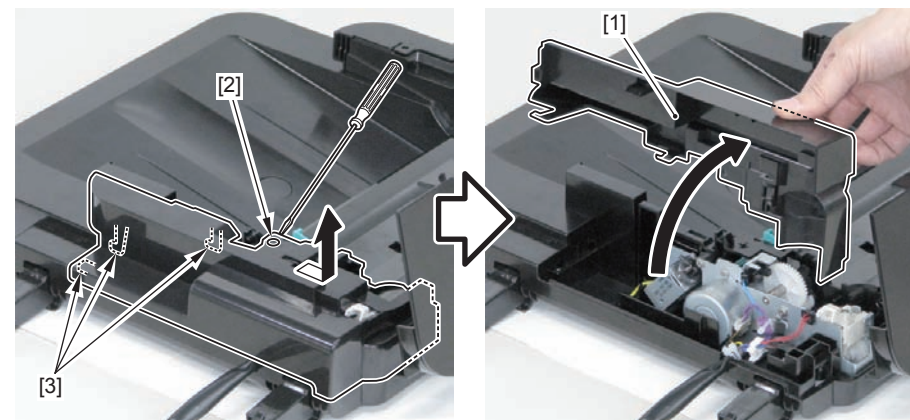

F-4-57

4) Remove the DADF Front Cover [1].

- 1 Boss [2]
- 4 Claws [3]

NOTE:

The locations of the 4 claws [3] of the DADF Front Cover are shown here.

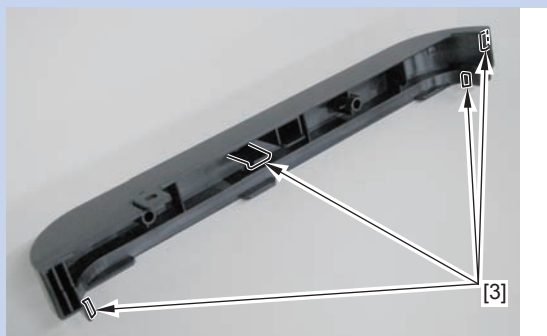

F-4-58

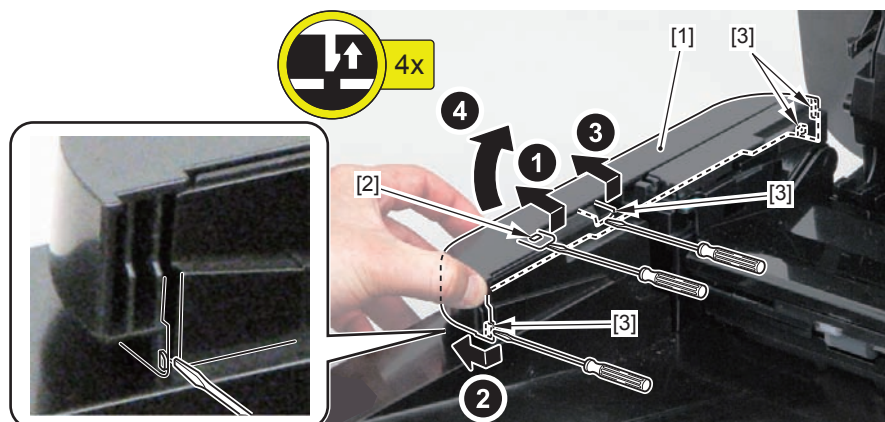

F-4-59

NOTE: How to assemble the DADF Front Cover

Be sure to align the 2 claws [3] on the left side with the holes [A] of the DADF Front Cover to install the cover.



F-4-60

5) Remove the DADF Pickup Front Cover [1].

- 1 Claw [2]
- 3 Hooks [3]

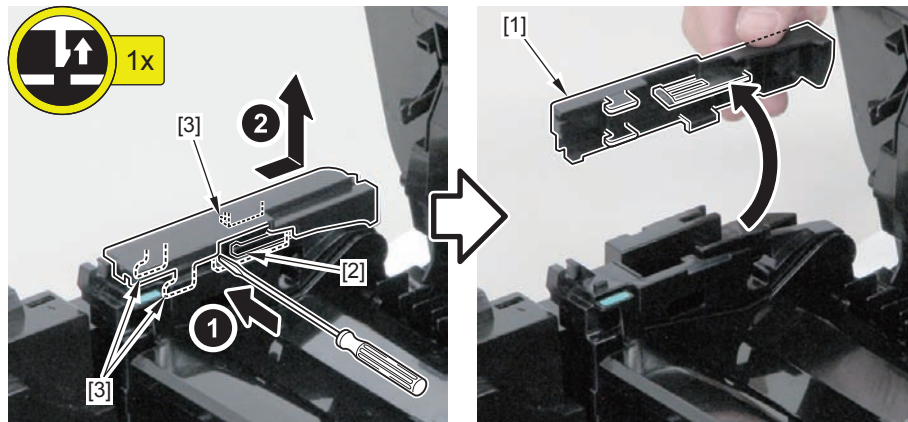

F-4-61

6) Remove the Wire Saddle [1], the Harness Guide [2], and the 4 screws [3].

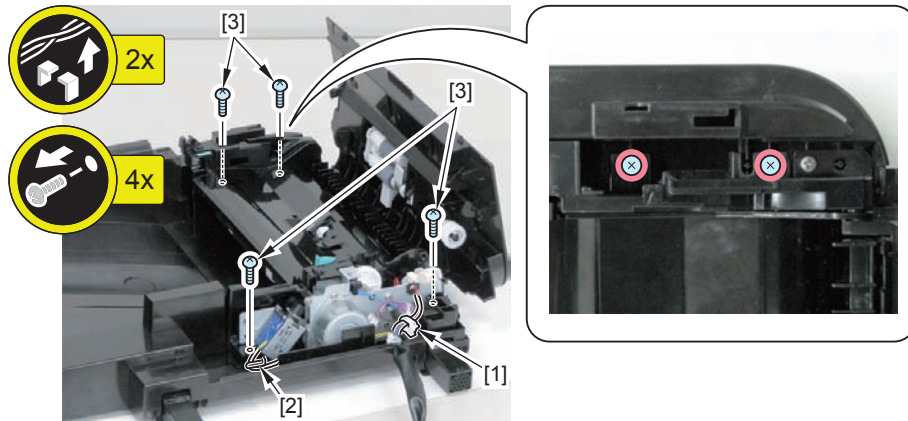

F-4-62

7) Close the DADF Upper Cover Unit [1], and remove the DADF Pickup Unit [2].

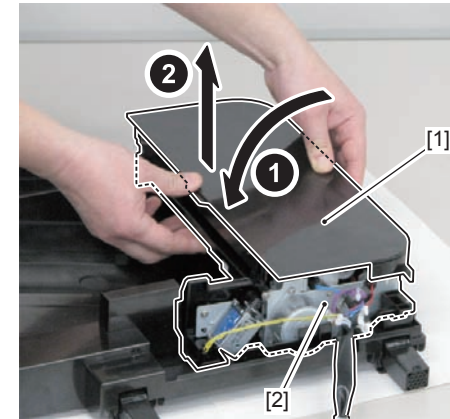

F-4-63

8) Remove the DADF Upper Cover Unit [1].

- 2 Shafts [2]

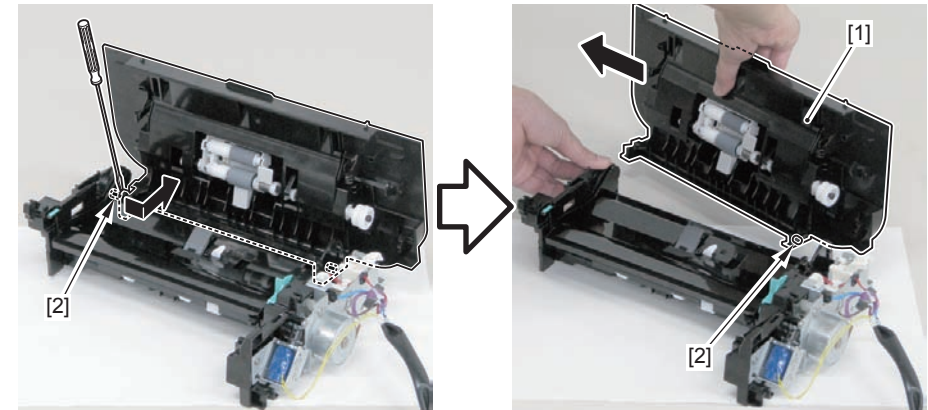

F-4-64

Removing the DADF Motor Unit

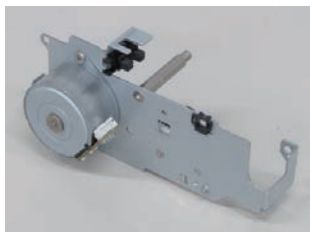

F-4-65

2) Remove the DADF Motor Unit [1].

- 3 Screws [2]

CAUTION:

Be sure to perform work carefully so as to displace the gear phase.

Preparation

- 1) Remove the Left Cover (Duplex Model) (Refer to page 4-86).
- 2) Remove the DADF Unit + Reader Unit (Refer to page 4-27).
- 3) Disconnecting the DADF Unit + Reader Unit (Refer to page 4-30).
- 4) Removing the DADF Pickup Unit (Refer to page 4-32).

Procedure

1) Remove the 2 connectors [1] and the Grounding Terminal [2] of the DADF Communication Cable.

- 1 Screw [3]
- 1 Edge Saddle [4]
- 1 Harness Guide [A].

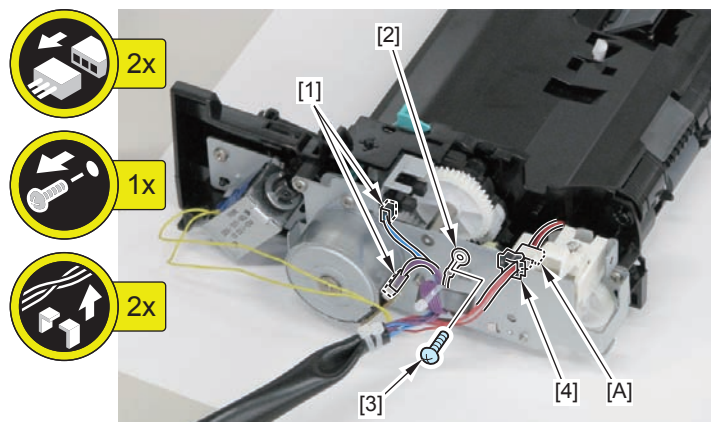

F-4-66

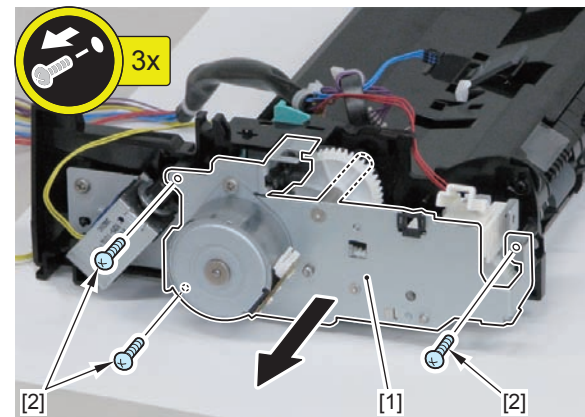

F-4-67

NOTE: How to assemble the DADF Motor Unit

1) Assemble it in the following order.

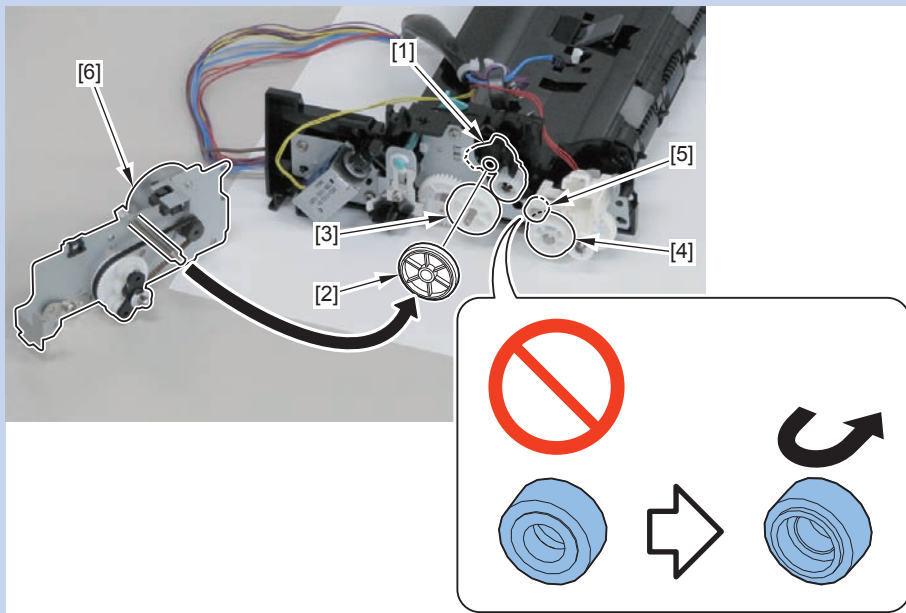

F-4-68

- [1] Separation Swing Arm
- [2] Separation Gear 21T/42T
- [3] Gear 17T/51T
- [4] Gear 23T/46T
- [5] Gear 20T
- [6] DADF Motor Unit

NOTE: How to assemble the DADF Motor Unit

2) Ensure that the 2 points [A] in the DADF Pickup Unit and DADF Motor Unit are in contact with the 2 edges of the shafts.

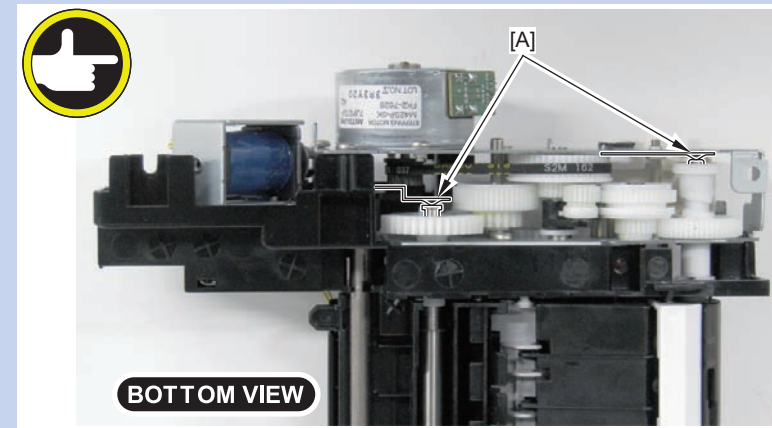

F-4-69

Removing the DADF Solenoid Unit



F-4-70

Preparation

- 1) Remove the Left Cover (Duplex Model) (Refer to page 4-86).
- 2) Remove the DADF Unit + Reader Unit (Refer to page 4-27).
- 3) Disconnecting the DADF Unit + Reader Unit (Refer to page 4-30).
- 4) Removing the DADF Pickup Unit (Refer to page 4-32).
- 5) Remove the DADF Motor Unit (Refer to page 4-36).

Procedure

CAUTION:

Be sure to perform work carefully so as to displace the gear phase.

- 1) Remove the DADF Solenoid Unit [1].

- 1 E-ring [2]
- 2 Screws [3]
- 3 Harness Bands [4]

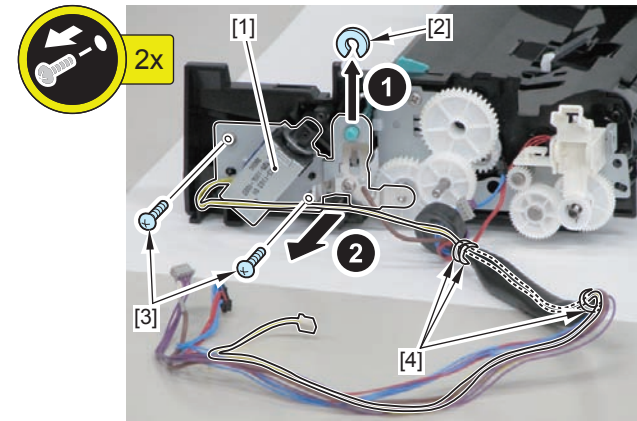

F-4-71

NOTE: How to assemble the DADF Solenoid Unit

- Pass the Solenoid Shaft [1] through the hole [A] of the Solenoid Arm.
- Ensure that the 2 points on the DADF Pickup Unit Shaft [2] and the 2 contact points [B] on the DADF Solenoid Unit are in contact with each other.

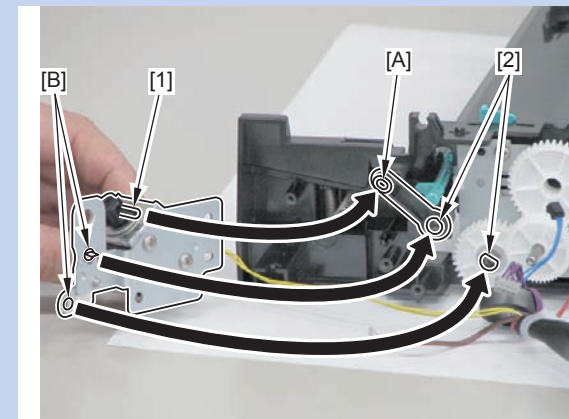

F-4-72

Removing the DADF Pickup Roller Unit

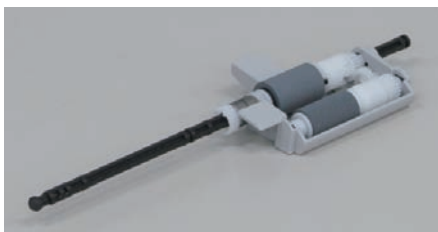

F-4-73

Procedure

CAUTION:

Do not touch the surface of the Pickup Roller.

1) Open the Original Feed Auxiliary Tray [1] and DADF Upper Cover Unit [2].

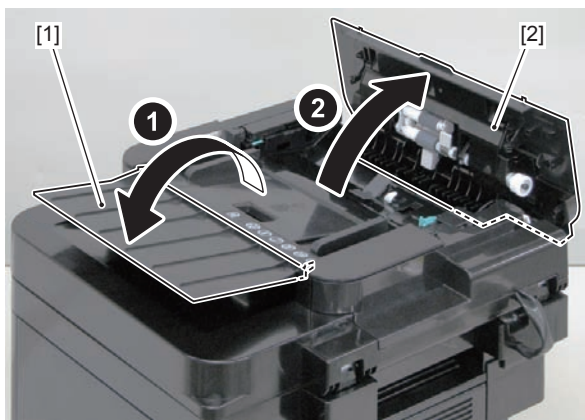

F-4-74

2) Remove the DADF Upper Cover Unit [1].

- 2 Bosses [2]
- 7 Hooks [3]

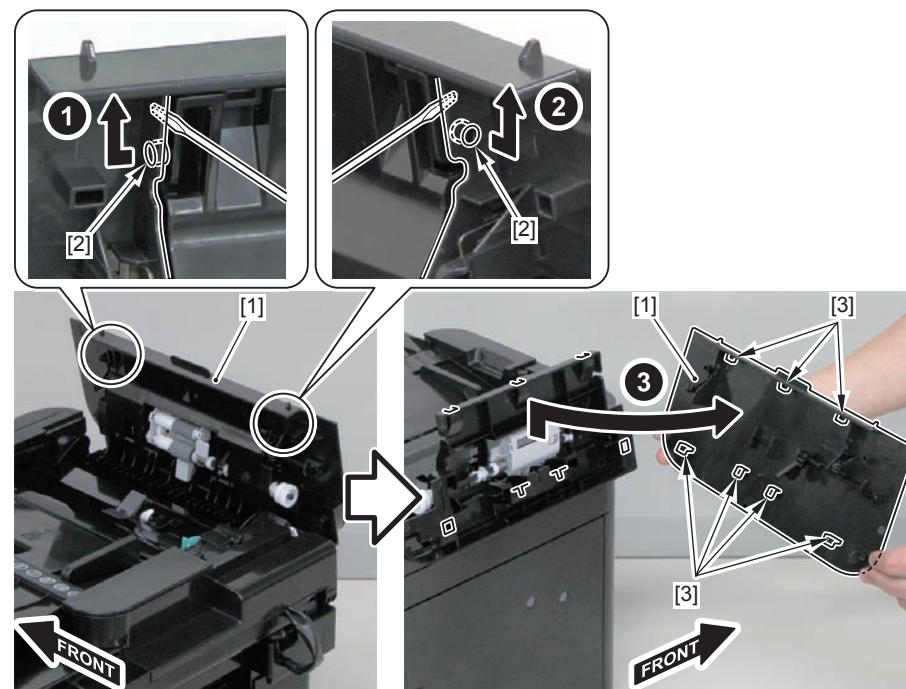

F-4-75

3) Remove the gear [1].

- 1 Claw [2]

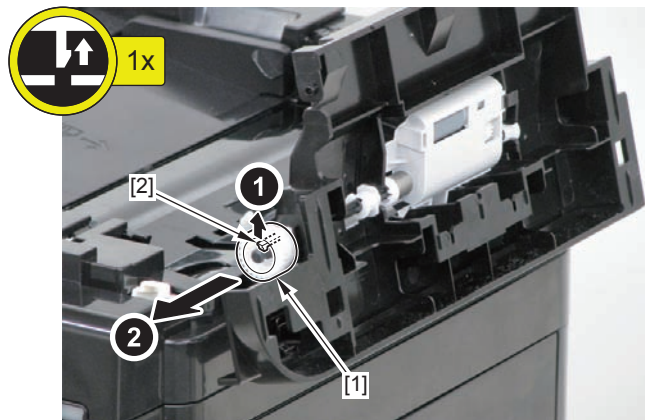

F-4-76

4) Remove the 2 E-rings [1] and the 2 bushings [2].

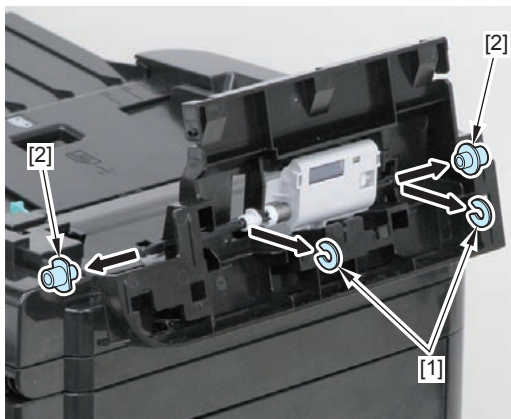

F-4-77

5) Move the bushing [1], and remove the Pickup Roller [2].

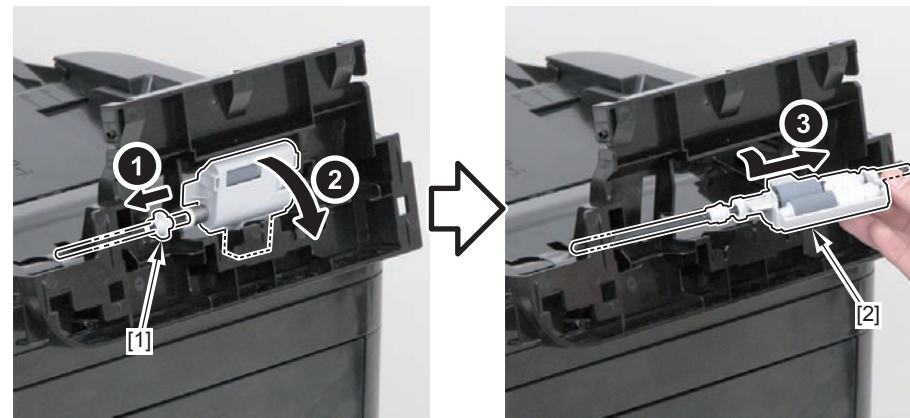

F-4-78

6) Remove the spring [1] and the bushing [2].

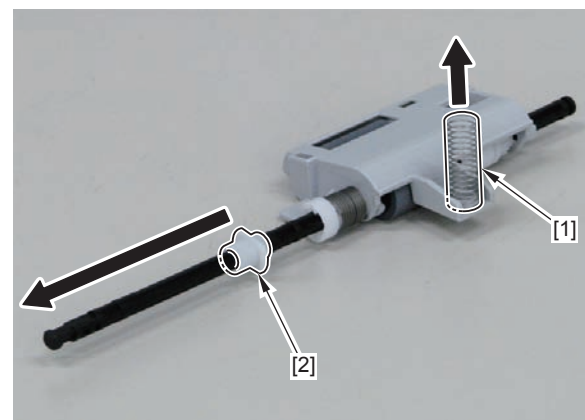

F-4-79

NOTE: How to assemble the DADF Pickup Roller Unit

- 1) Assemble it by aligning the spring [1] with the boss [2].

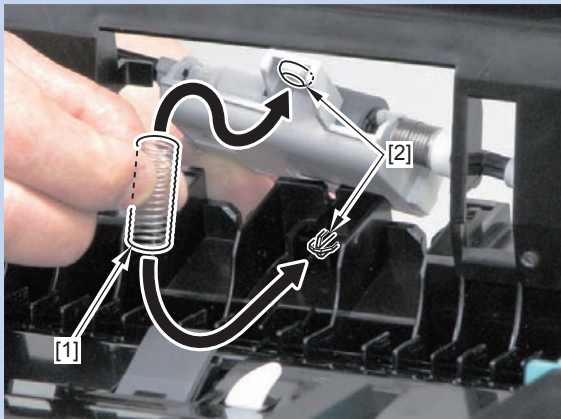

F-4-80

- 2) Be sure to align the orientation of the edge [A] of the 2 bushings [1] in the vertical direction.

- 1 E-ring [2]

- 3) Be sure to align the gear [3] with the D-cut [B] of the DADF Pickup Roller Shaft.

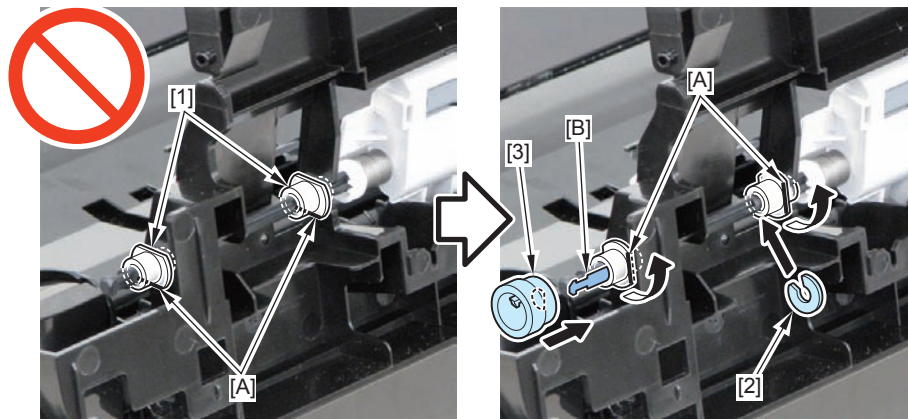

F-4-81

Removing the DADF Separation Pad



F-4-82

Procedure

CAUTION:

- Do not touch the pad surface.
- Do not lose the spring [1] on the back side of the DADF Separation Pad.

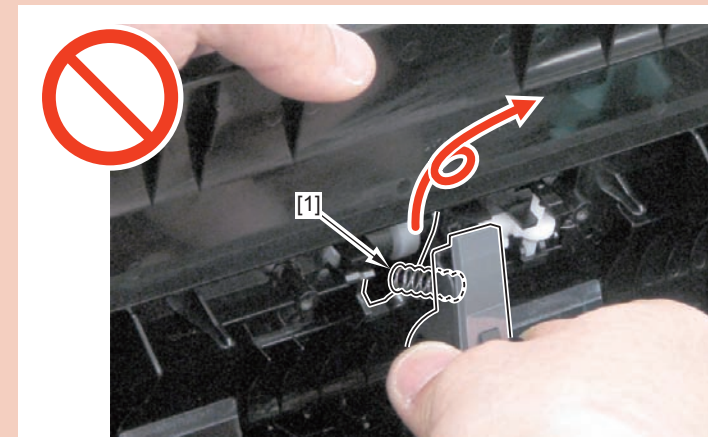

F-4-83

- 1) Open the Original Feed Auxiliary Tray [1], the DADF Upper Cover Unit [2], and the DADF Inner Guide [3].

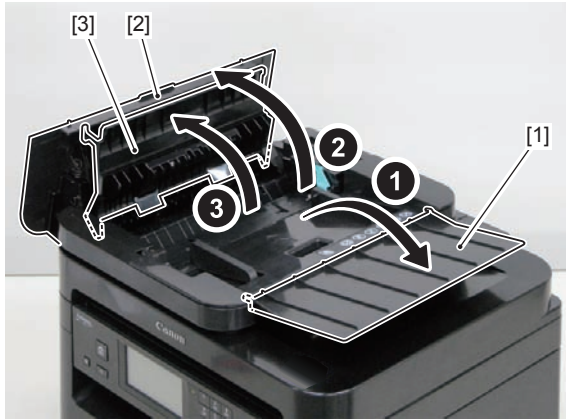

F-4-84

- 2) Hold the 2 protrusions [A] of the DADF Separation Pad, and remove the DADF Separation Pad Cover [1].

- 2 Screws [2]

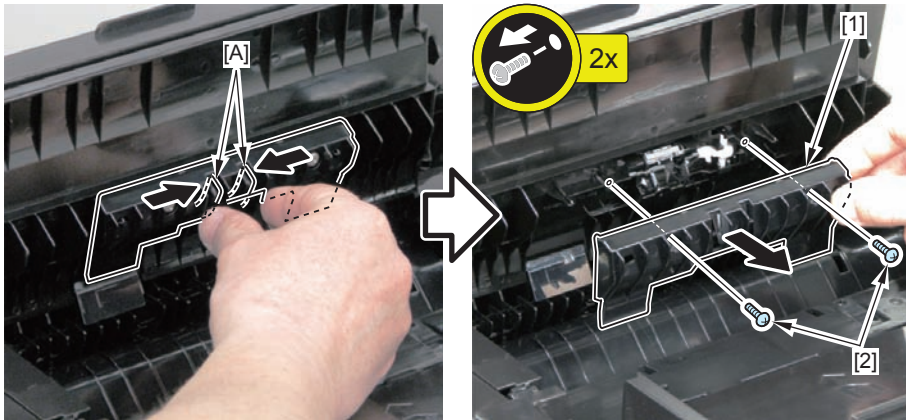

F-4-85

- 3) Remove the DADF Separation Pad [1].

- 2 Shafts [2]

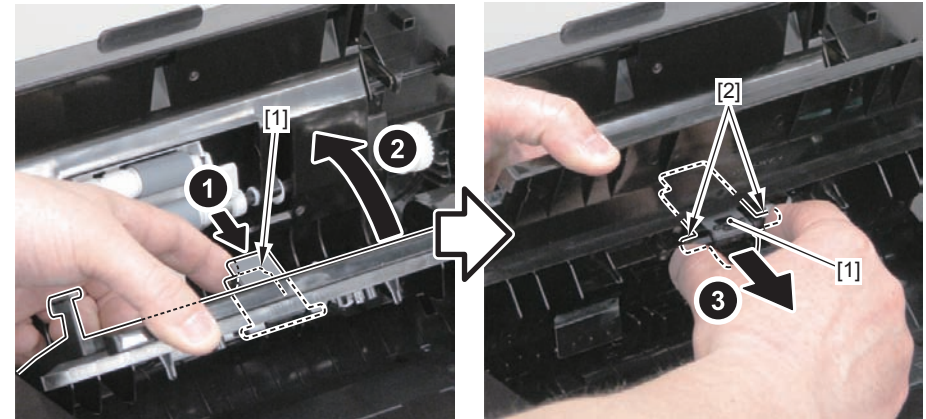

F-4-86

- 4) Remove the spring [2] from the DADF Separation Pad [1].

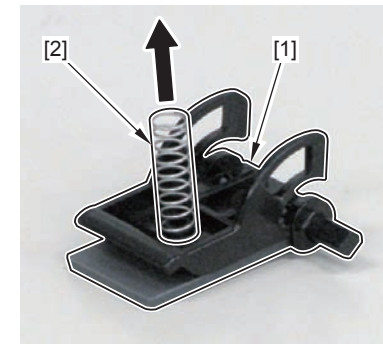

F-4-87

NOTE: How to assemble the DADF Separation Pad

- 1) Insert the spring [1] into the boss [2].

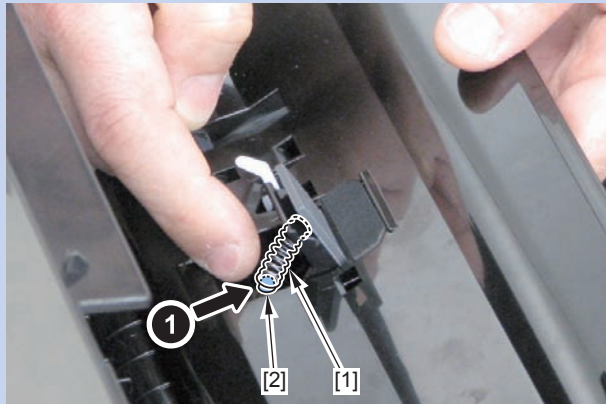

F-4-88

- 2) Install the DADF Separation Pad Cover [1].

- 2 Screws [2]

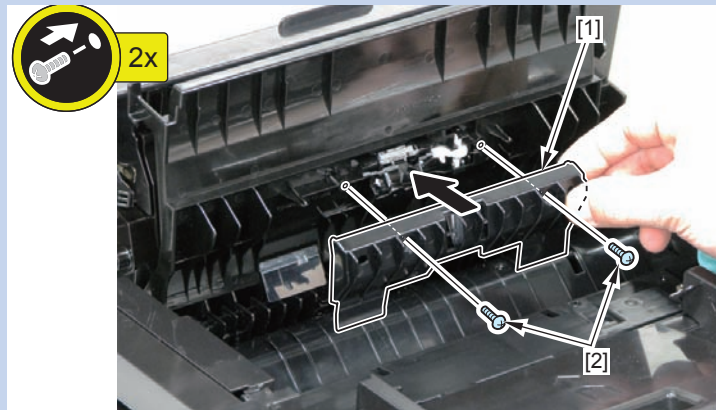

F-4-89

NOTE: How to assemble the DADF Separation Pad

- 3) Assemble it by pressing the DADF Separation Pad [1] and hooking the claw [2].

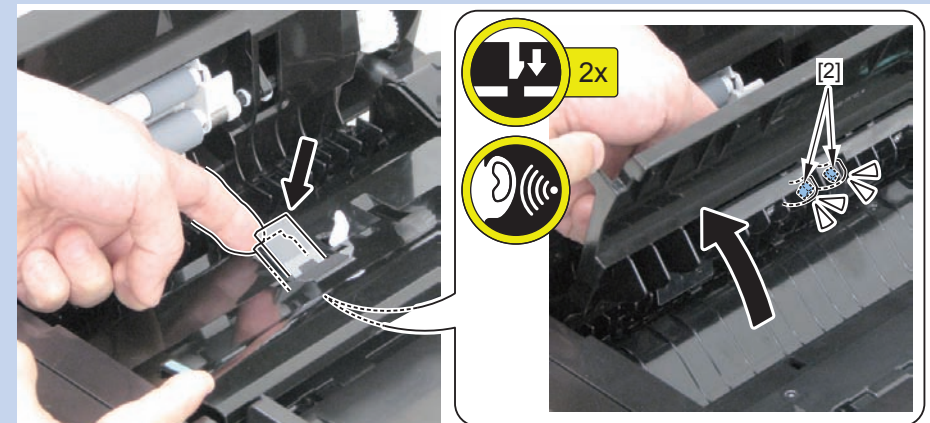

F-4-90

Removing the Copyboard Glass (DADF Model)

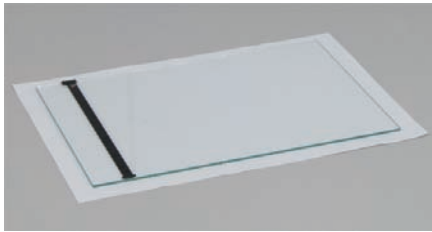

F-4-91

Preparation

- 1) Remove the Left Cover (Duplex Model) (Refer to page 4-86).
- 2) Remove the DADF Unit + Reader Unit (Refer to page 4-27).
- 3) Disconnecting the DADF Unit + Reader Unit (Refer to page 4-30).

Procedure

CAUTION:

- Be sure to place the removed Copyboard Glass on a cloth, etc. to avoid damaging the bottom sheet.
- When removing the Copyboard Glass, be careful not to touch the glass surface.
- If the surface becomes dirty, clean it with lint free paper.



F-4-92

- 1) Remove the 2 screws [1].

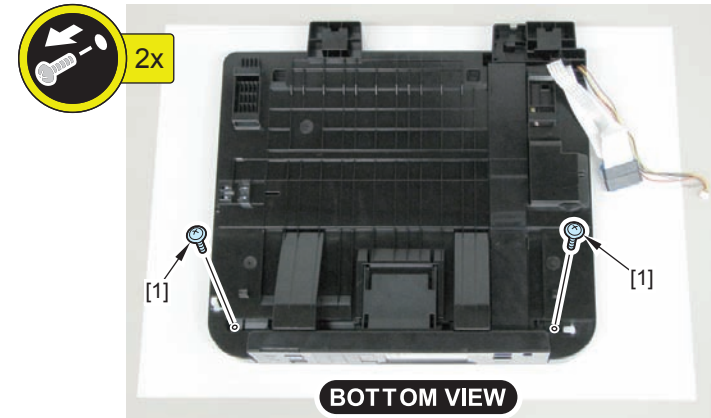

F-4-93

- 2) Remove the Copyboard Guide Holder [1].

- 1 Claw [2]
- 1 Hook [3]

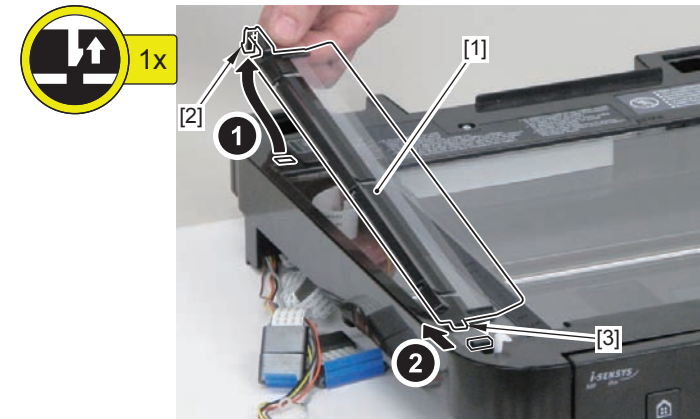

F-4-94

3) Remove the Reader Upper Cover Unit [1].

- 2 Screws [2]
- 5 Claws A [3]
- 1 Claw B [4]

NOTE:

The following shows the 5 claws A [3] and the claw B [4] of the Reader Upper Cover Unit.

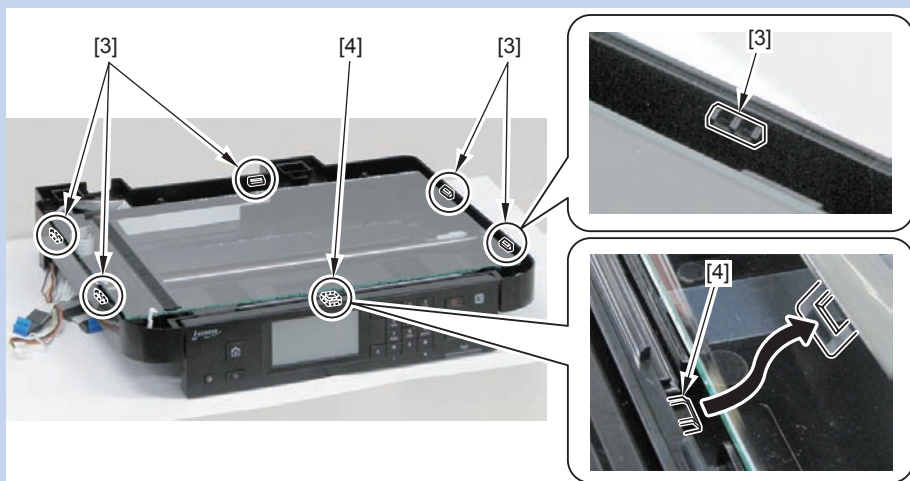

F-4-95

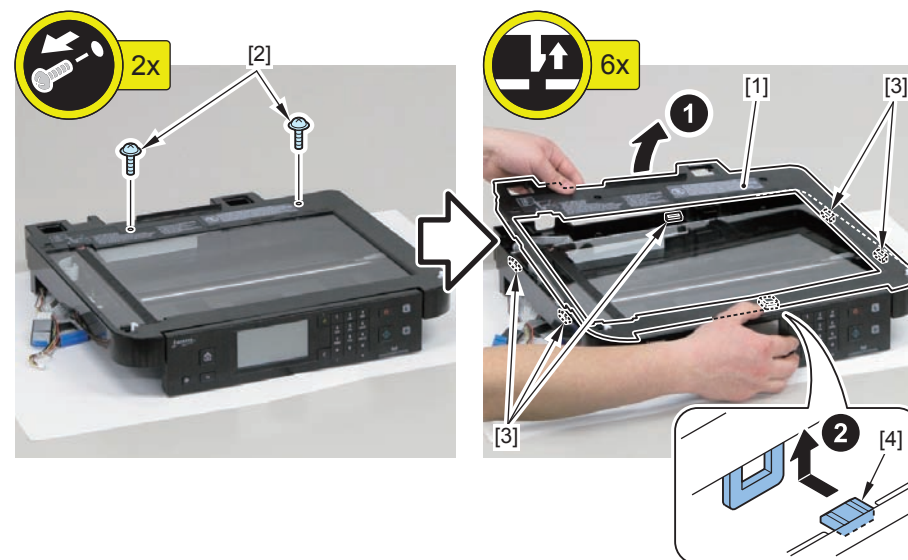

F-4-96

4) Remove the Copyboard Glass [1].

CAUTION:

- Do not lose the 2 spacers [1] of the Contact Image Sensor Unit.
- Do not touch the document reading part [A] of the Contact Image Sensor Unit.

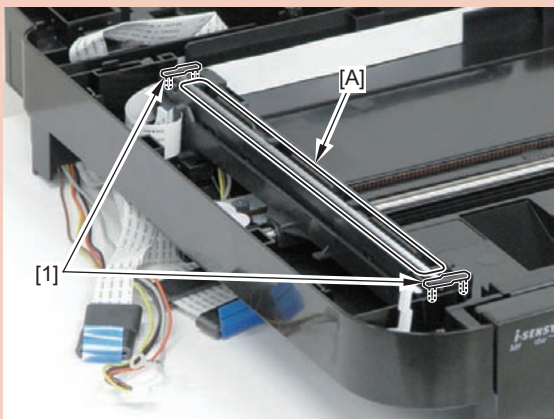

F-4-97

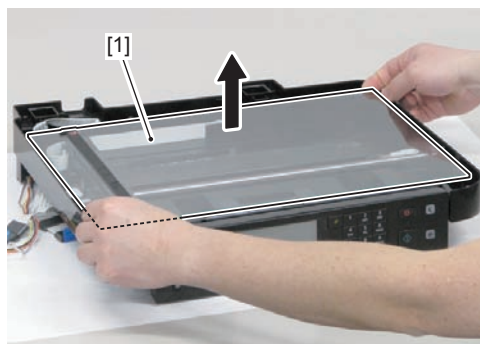

F-4-98

Removing the Contact Image Sensor (DADF Model)



F-4-99

Preparation

- 1) Remove the Left Cover (Duplex Model) (Refer to page 4-86).
- 2) Remove the DADF Unit + Reader Unit (Refer to page 4-27).
- 3) Disconnecting the DADF Unit + Reader Unit (Refer to page 4-30).
- 4) Remove the Copyboard Glass (DADF Model) (Refer to page 4-44).

Procedure

CAUTION:

- Do not lose the 2 spacers [1] of the Contact Image Sensor Unit.
- Do not touch the document reading part [A] of the Contact Image Sensor Unit.

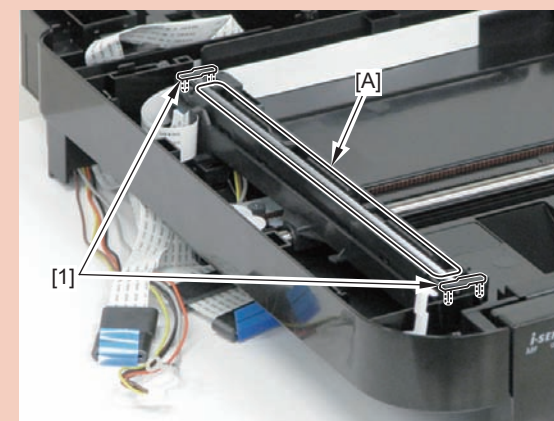

F-4-100

1) Move the Contact Image Sensor Unit [1].

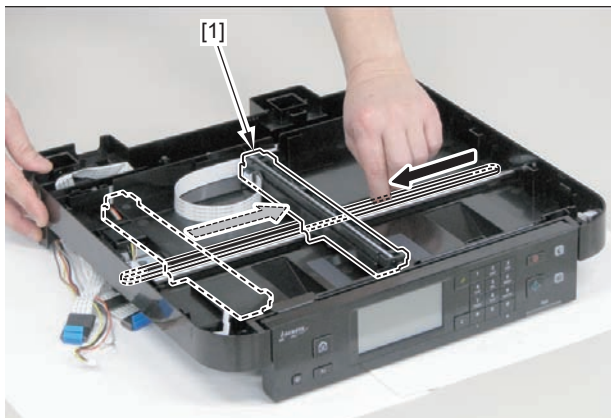

F-4-101

2) Remove the 2 spacers [1] and the Flat Cable [2].

• 1 Guide [A]

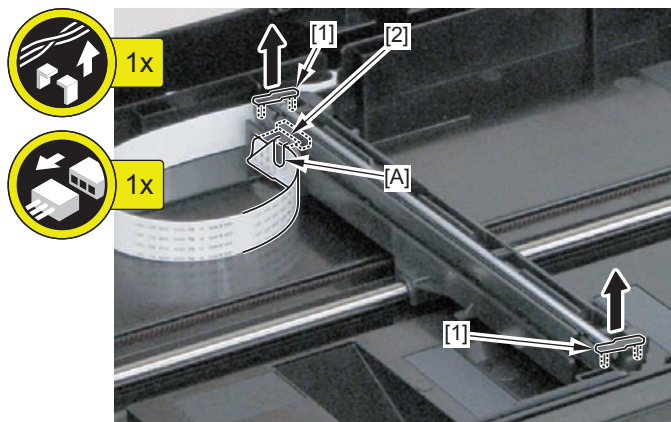

F-4-102

3) Remove the Contact Image Sensor [1].

• 2 Shafts [2]

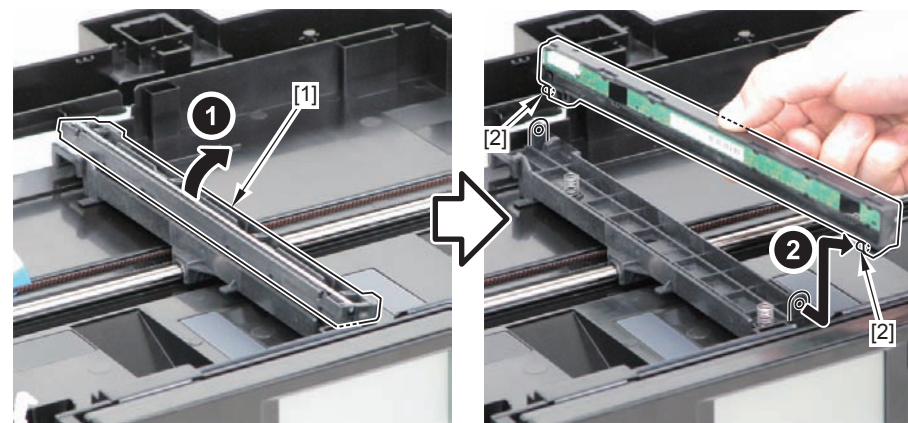

F-4-103

CAUTION:

If the Contact Image Sensor Unit comes off, be sure to put the tooth [1] of the belt in the groove [2] on the bottom of the Contact Image Sensor to install the unit.

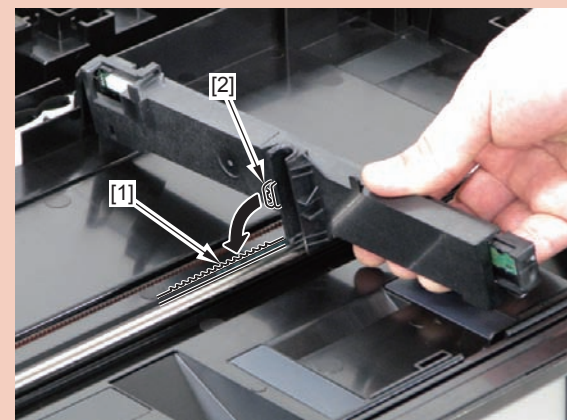

F-4-104

Removing the Flat Bed Motor Unit (DADF Model)

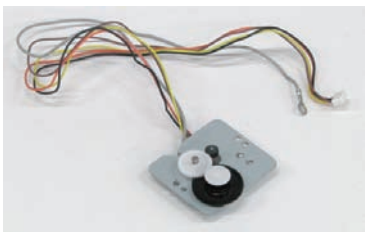

F-4-105

Preparation

- 1) Remove the Left Cover (Duplex Model) (Refer to page 4-86).
- 2) Remove the DADF Unit + Reader Unit (Refer to page 4-27).
- 3) Disconnecting the DADF Unit + Reader Unit (Refer to page 4-30).
- 4) Remove the Copyboard Glass (DADF Model) (Refer to page 4-44).

Procedure

CAUTION:

- Do not lose the 2 spacers [1] of the Contact Image Sensor Unit.
- Do not touch the document reading part [A] of the Contact Image Sensor Unit.

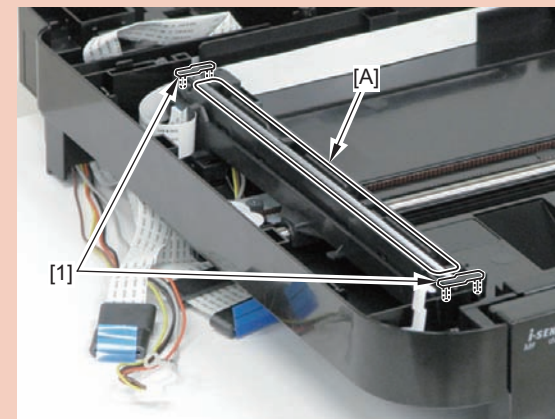

F-4-106

- 1) Move the Contact Image Sensor Unit [1].

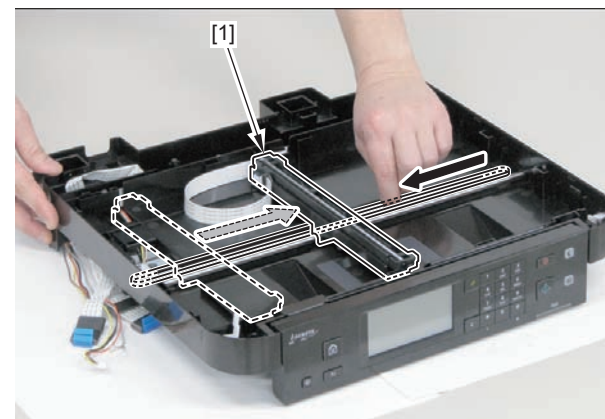

F-4-107

2) Press the gear [1] to bend the belt [2], and remove the belt [2] from the gear [3].

CAUTION:

Grease is applied on the shaft [4] of the Contact Image Sensor, so be careful not to let the belt [2] come in contact with the shaft.

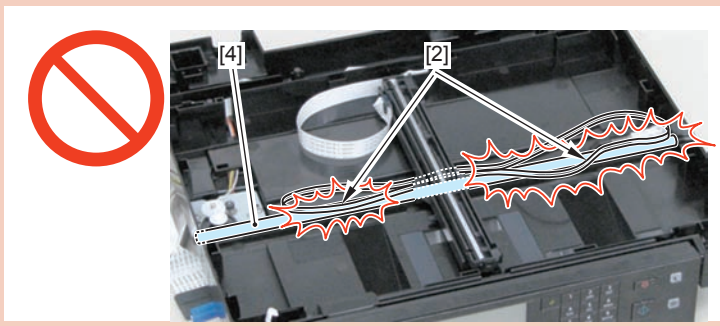

F-4-108

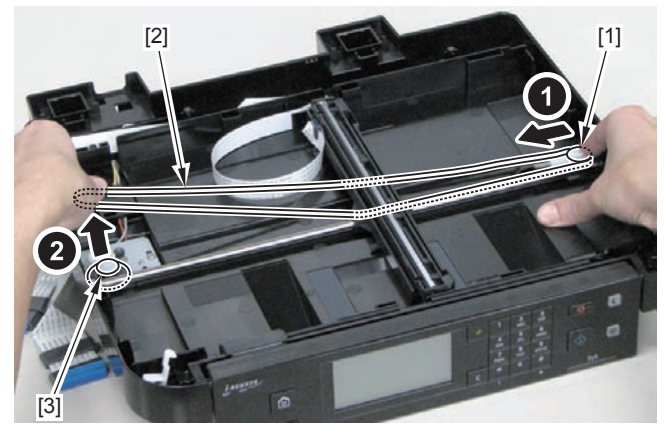

F-4-109

3) Remove the Guide Cover [1].

- 1 Claw [2]

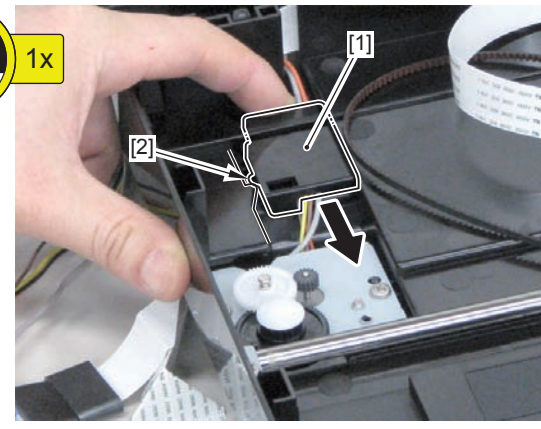

F-4-110

4) Free the harness [1] and the Grounding Wire [2] from the hole [A] of the Reader Unit and the Harness Guide [B].

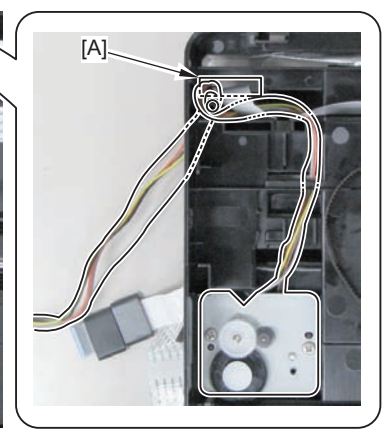
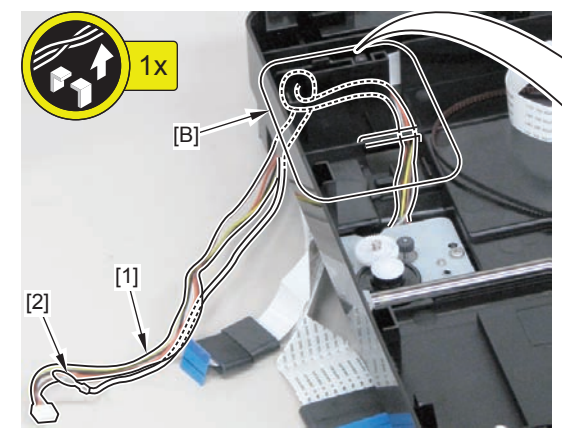

F-4-111

5) Remove the Flat Bed Motor Unit [1].

- 2 Screws [2]

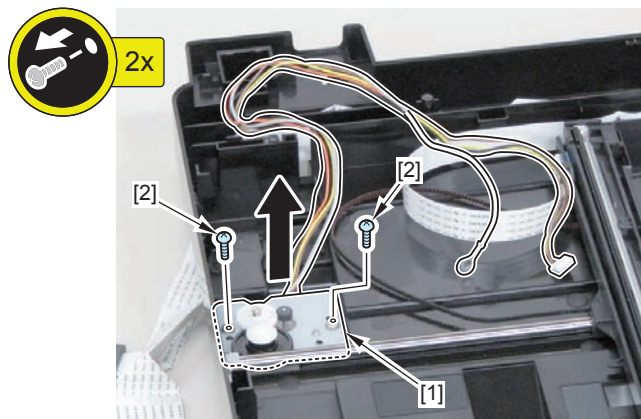

F-4-112

CAUTION:

If the Contact Image Sensor Unit comes off, be sure to put the tooth [1] of the belt in the groove [2] on the bottom of the Contact Image Sensor to install the unit.

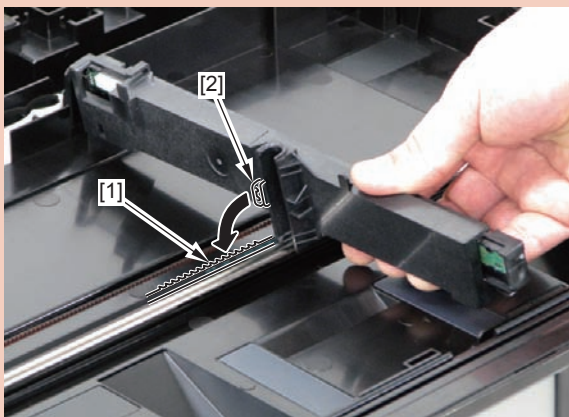

F-4-113

Original Exposure/Feed System (SADF Model)

Layout Drawing

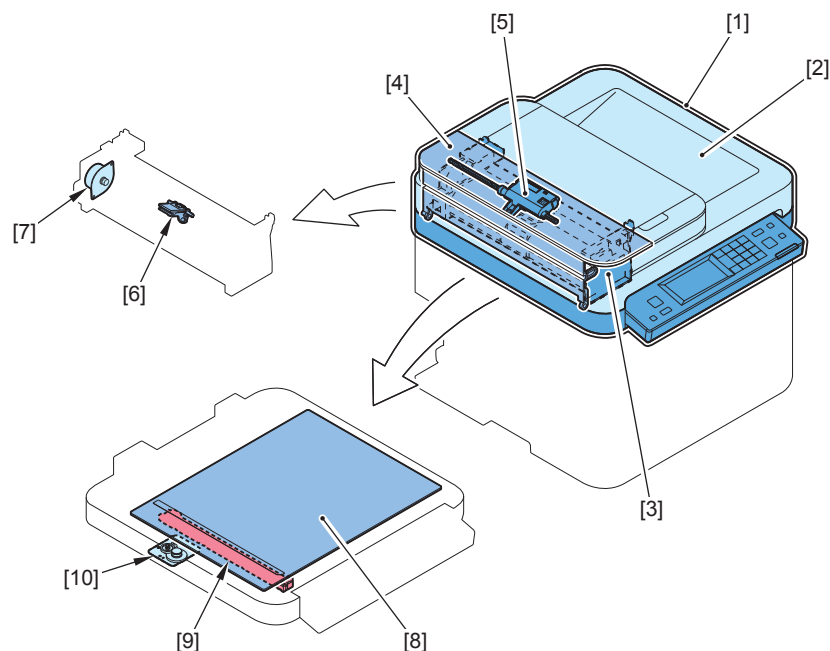

F-4-114

No.	Name	Reference	Remarks
[1]	SADF Unit and Reader Unit	(Refer to page 4-51)	
[2]	SADF Unit	(Refer to page 4-54)	
[3]	SADF Pickup Unit	(Refer to page 4-60)	
[4]	SADF Upper Cover Unit	(Refer to page 4-56)	
[5]	SADF Pickup Roller Unit	(Refer to page 4-62)	
[6]	SADF Separation Pad	(Refer to page 4-65)	
[7]	SADF Motor Unit	(Refer to page 4-61)	
[8]	Copyboard Glass	(Refer to page 4-68)	
[9]	Contact Image Sensor	(Refer to page 4-70)	
[10]	Flatbed Motor Unit	(Refer to page 4-72)	

T-4-36

Removing the SADF Unit + Reader Unit.



F-4-115

Preparation

Duplex Model

1) Remove the Left Cover (Duplex Model) (Refer to page 4-86).

Simples Model

1) Remove the Left Cover (Simples Model)(Refer to page 4-144).

Procedure

1) Disconnect the 2 terminals [1] and the 3 connectors [4] of the Grounding Wire, and free the Grounding Wire and the harness [5] from the Harness Guide [A].

- 1 Screw (black TP) [2]
- 1 Wire Saddle [3]

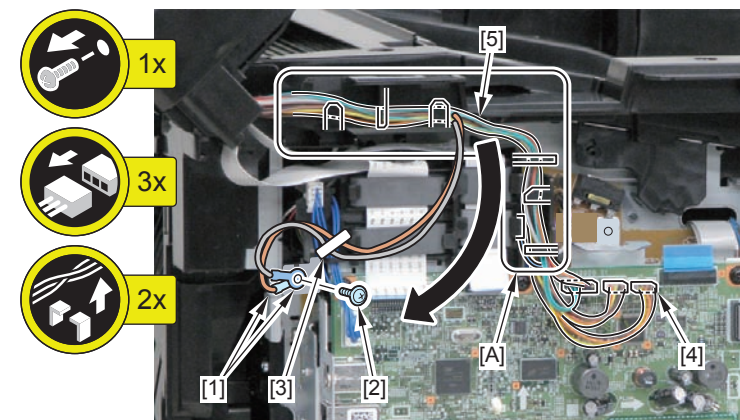

F-4-116

2) Free the 2 Flat Cables [1] from the Harness Guide [A].

- 4 Ferrite Cores [2]
- 4 Claws [3]

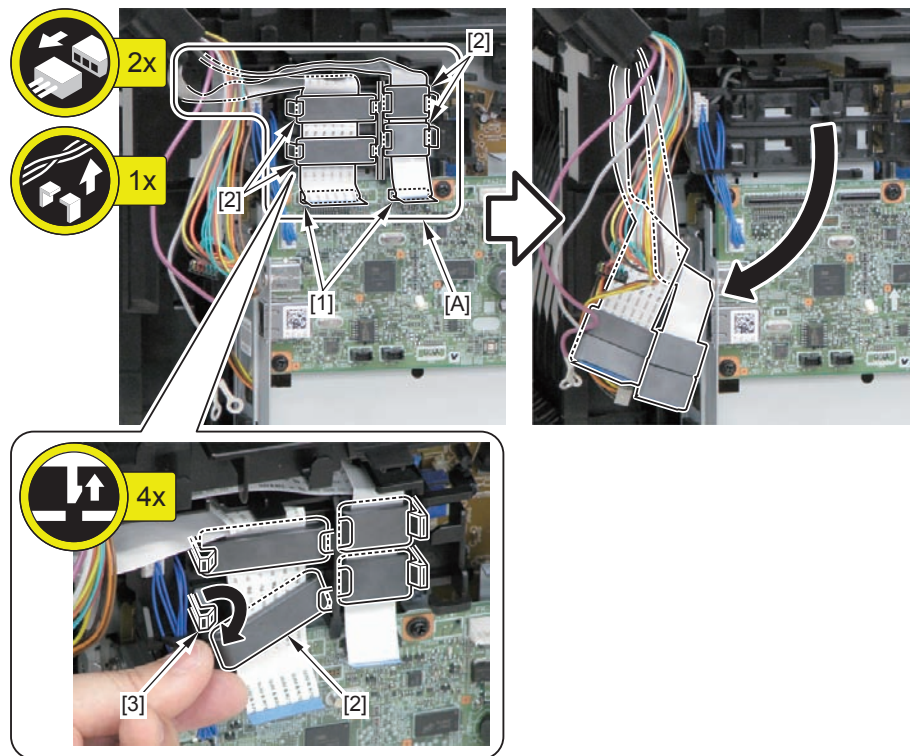

F-4-117

3) Remove the SADF Unit + Reader Unit [1].

- 2 Claws [2]

CAUTION:

- Be sure to install/remove the unit carefully so as not to damage the Flat Cable [3] and harness [4] with the [A] part.

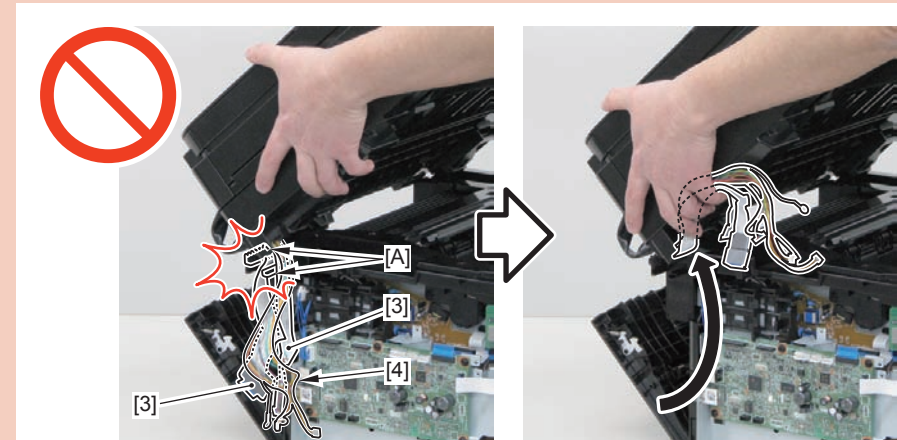

F-4-118

- Be sure to place the unit so as not to damage the Flat Cable [3] and harness [4].

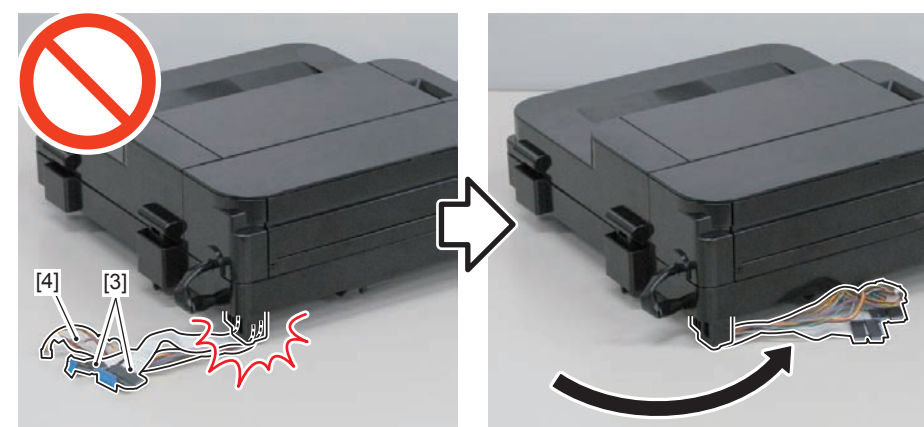

F-4-119

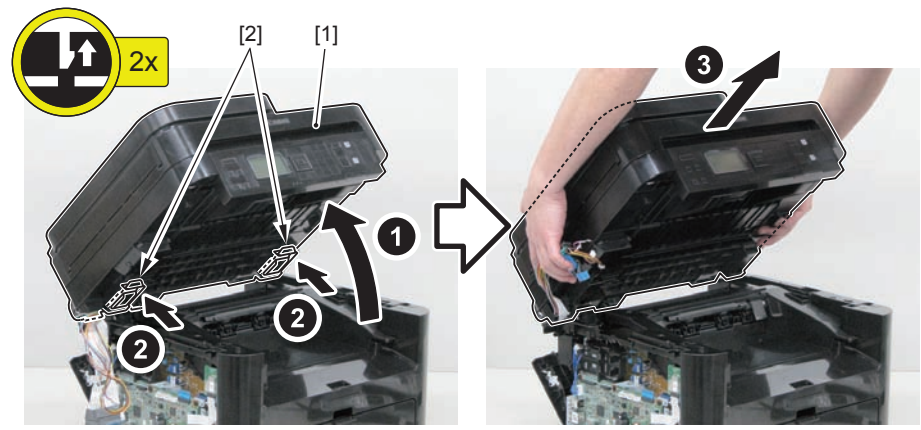

F-4-120

NOTE: How to assemble the SADF Unit + Reader Unit

Be sure to secure the 2 claws [1] of the Hinge Arm to the 2 hooks [2] of the Reader Unit.

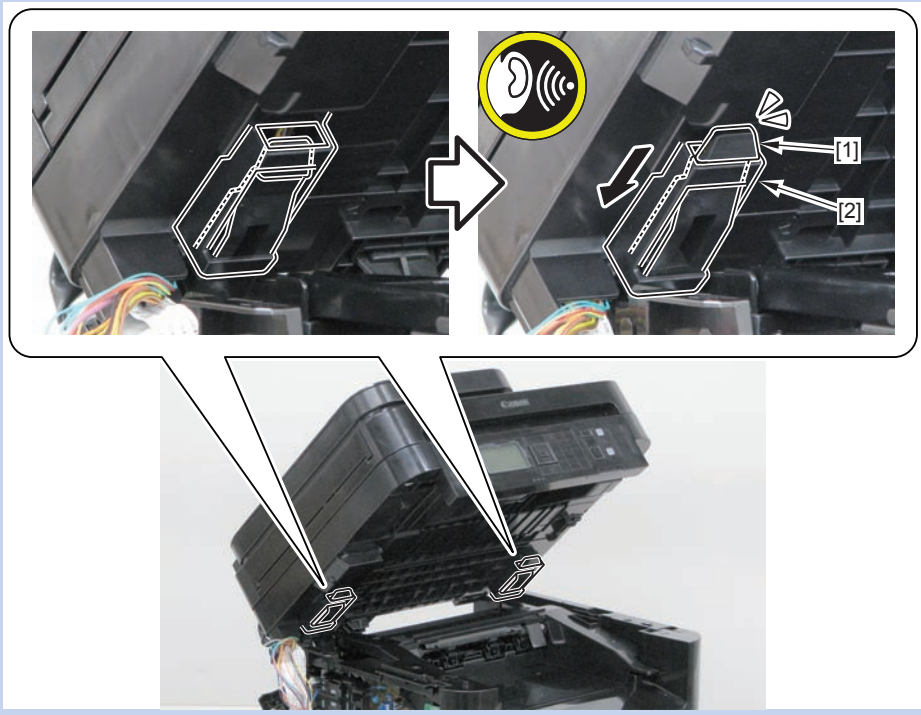

F-4-121

NOTE:

The following shows how to route the harness.

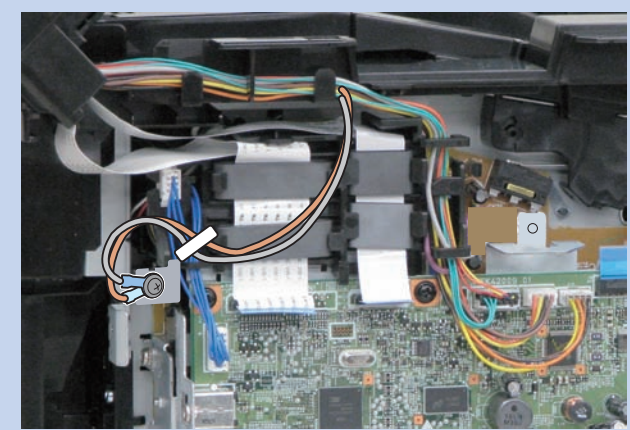

F-4-122

Disconnecting the SADF Unit and the Reader Unit



F-4-123

Preparation

Duplex Model

- 1) Remove the Left Cover (Duplex Model) (Refer to page 4-86).
- 2) Remove the SADF Unit + Reader Unit (Refer to page 4-51).

Sinplex Model

- 1) Remove the Left Cover (Sinplex Model)(Refer to page 4-144).
- 2) Remove the SADF Unit + Reader Unit (Refer to page 4-51).

Procedure

- 1) Change the orientation of the Control Panel Unit [1] so that it is facing down.

CAUTION:

Be sure to put a piece of paper and place the Control Panel Unit [1] on it carefully so as not to damage it.

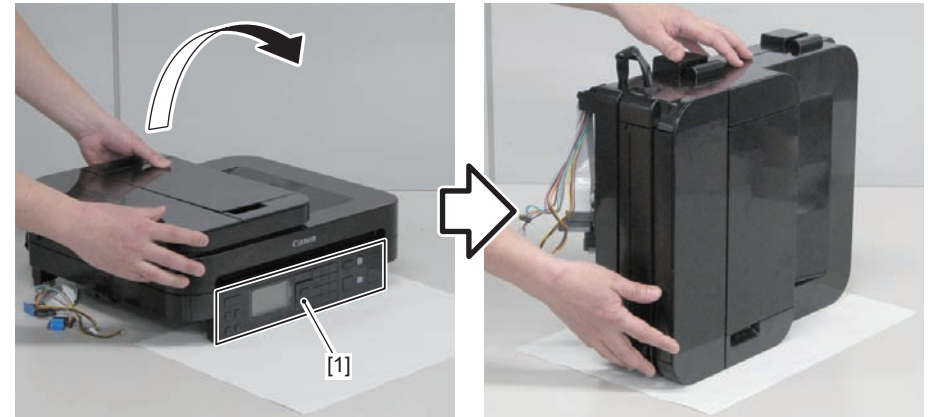

F-4-124

- 2) Remove the Harness Cover [1].

- 2 Claws [2]

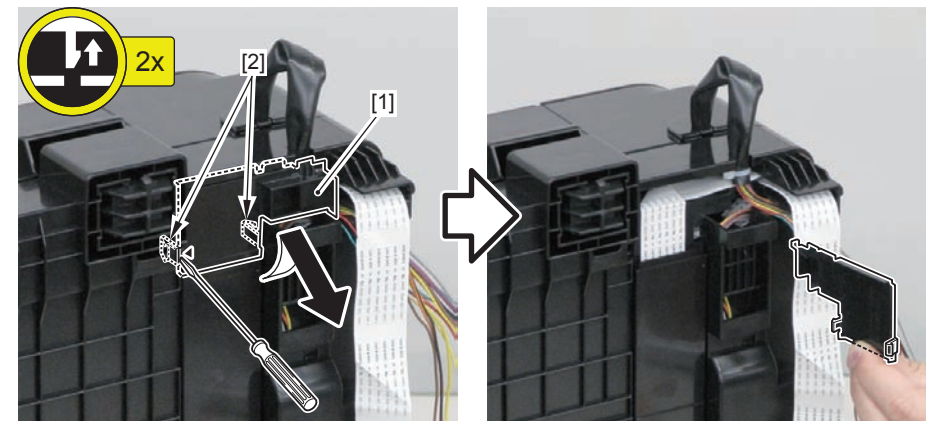

F-4-125

3) Free the harness [1] from the guide [A].

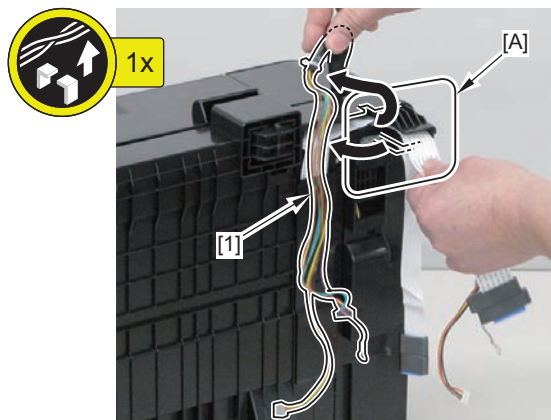

F-4-126

NOTE: How to Assemble the Harness Cover

As for the guide [A], be sure to install the Harness Cover after routing the harness [2] on the back side of the Flat Cable [1].

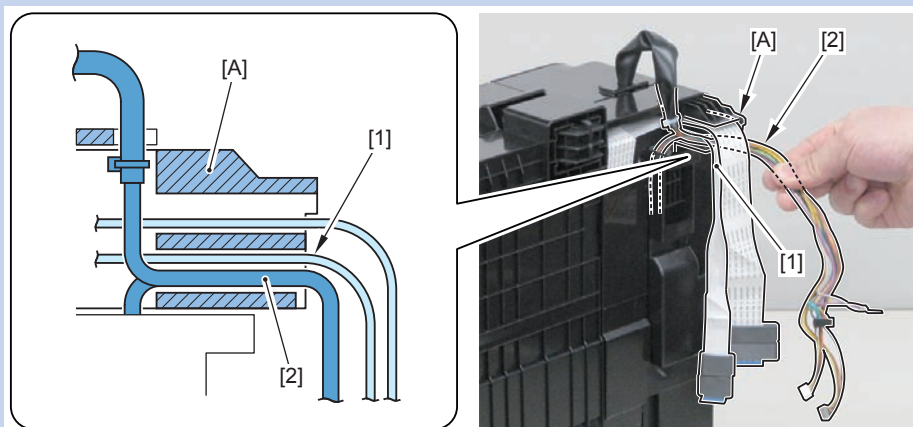

F-4-127

4) Change the orientation of the Reader Unit so that its bottom surface [1] is facing down.

5) Release the lock [2] and open the SADF Unit [3].

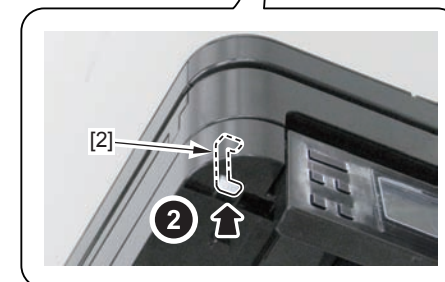
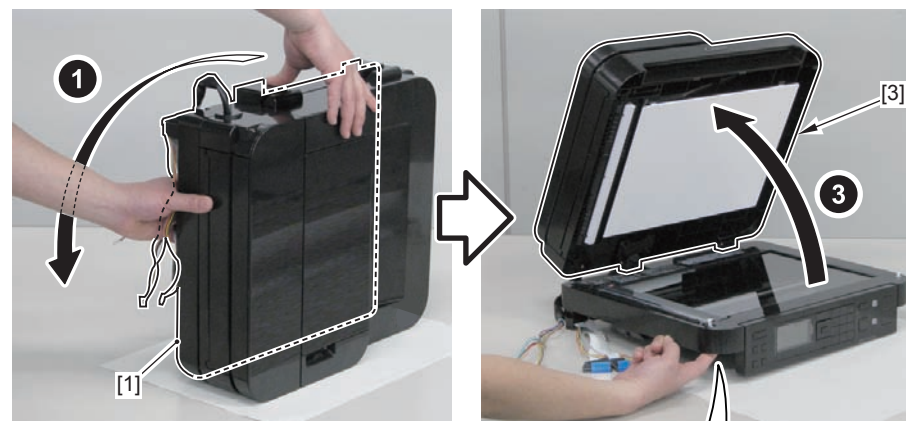

F-4-128

6) Separate the SADF Unit [1] and the Reader Unit [4].

- 1 Boss [2]
- 1 Claw [3]

CAUTION:

Do not damage the White Sheet [1] and White Guide Plate [2].



F-4-129

Removing the SADF Upper Cover Unit



F-4-131

Preparation

● Duplex Model

- 1) Remove the Left Cover (Duplex Model) (Refer to page 4-86).
- 2) Remove the SADF Unit + Reader Unit (Refer to page 4-51).
- 3) Separate the SADF Unit and the Reader Unit (Refer to page 4-54).

● Simplex Model

- 1) Remove the Left Cover (Simplex Model) (Refer to page 4-144).
- 2) Remove the SADF Unit + Reader Unit (Refer to page 4-51).
- 3) Separate the SADF Unit and the Reader Unit (Refer to page 4-54).

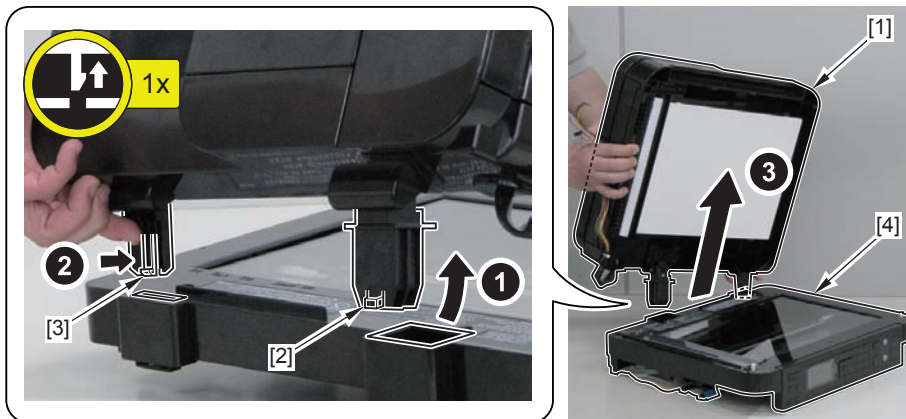

F-4-130

Procedure

- 1) Open the SADF Pickup Auxiliary Tray [1] and SADF Upper Cover Unit [2].
- 2) Close the SADF Pickup Auxiliary Tray [1].

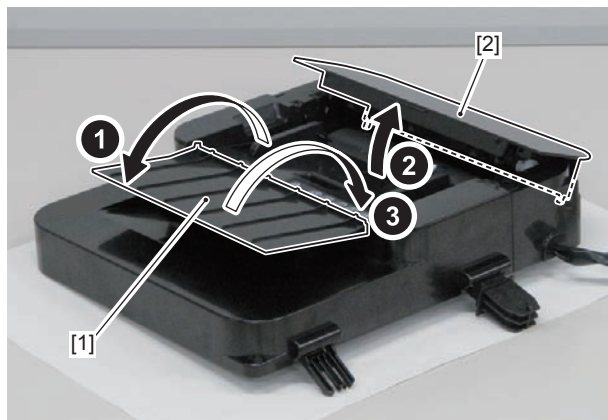

F-4-132

- 3) Remove the SADF Pickup Tray Unit [1].

- 1 Claw [2]

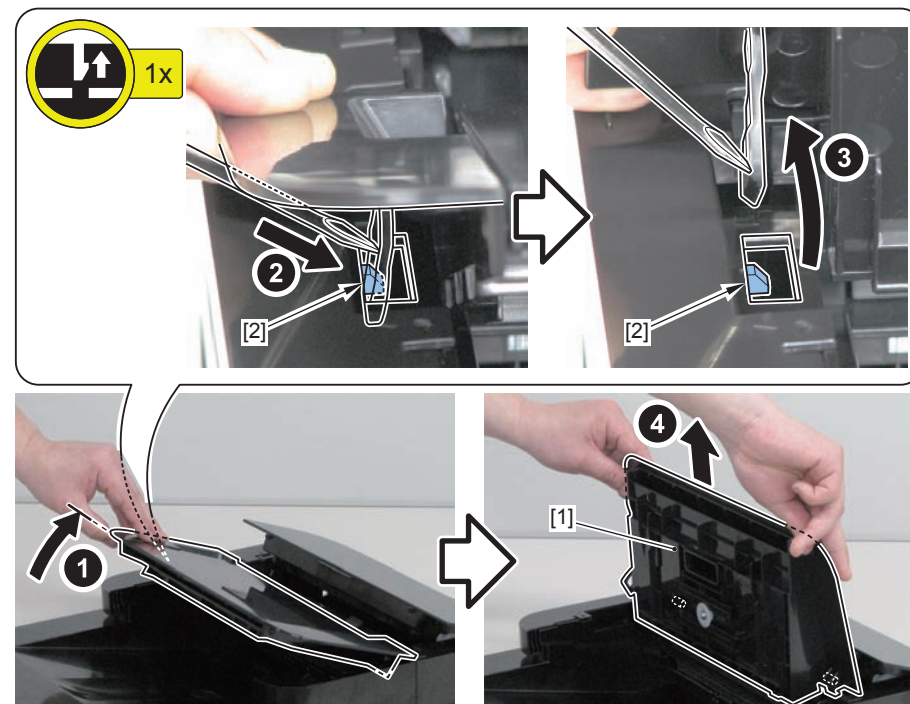

F-4-133

4) Remove the SADF Rear Cover [1].

- 3 Claws [2]

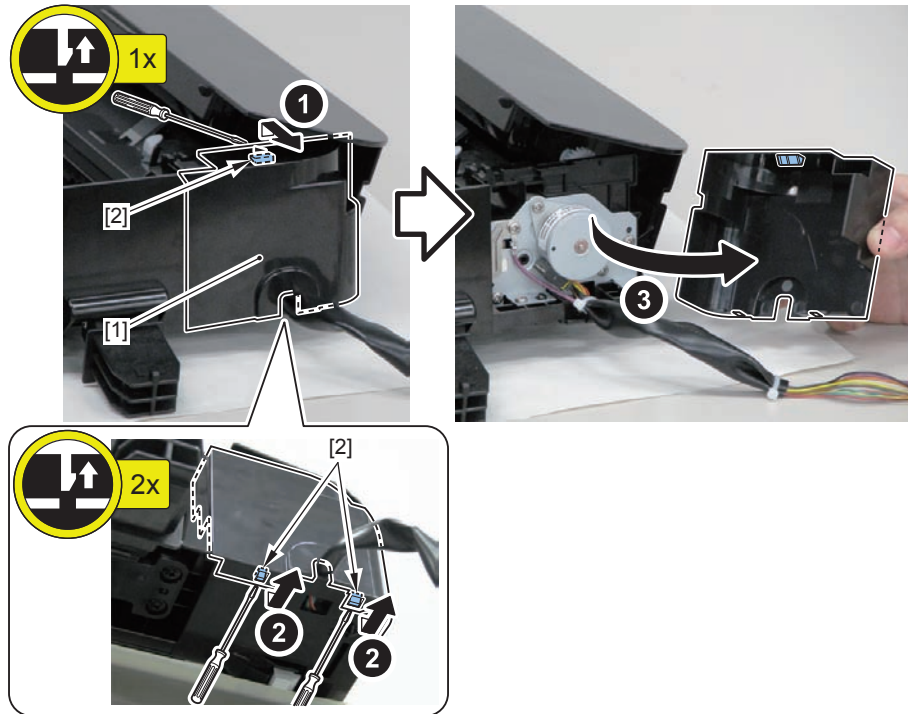

F-4-134

5) Remove the SADF Front Cover [1].

- 1 Boss [2]
- 3 Claws [3]

NOTE: SADF Front Cover

The locations of the 3 claws [3] of the SADF Front Cover are shown here.

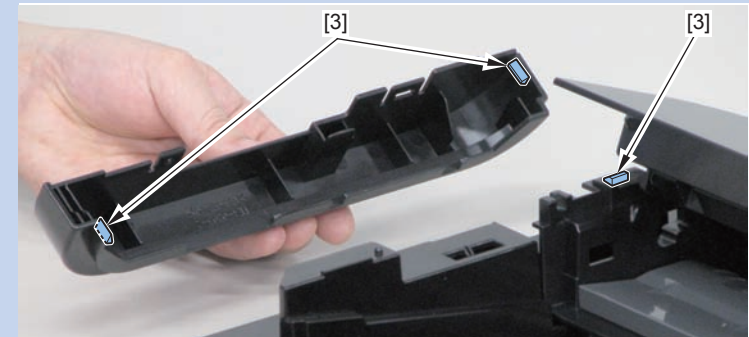

F-4-135

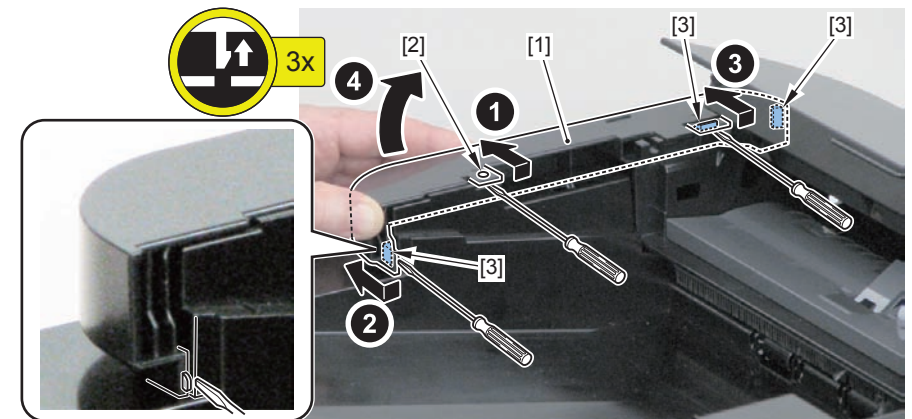

F-4-136

NOTE: How to assemble the SADF Front Cover

Be sure to align the claw [3] on the left side with the hole [A] of the SADF Front Cover to install the cover.



F-4-137

6) Remove the SADF Upper Cover Unit [1].

- 1 Boss [2]
- 2 Shafts [3]

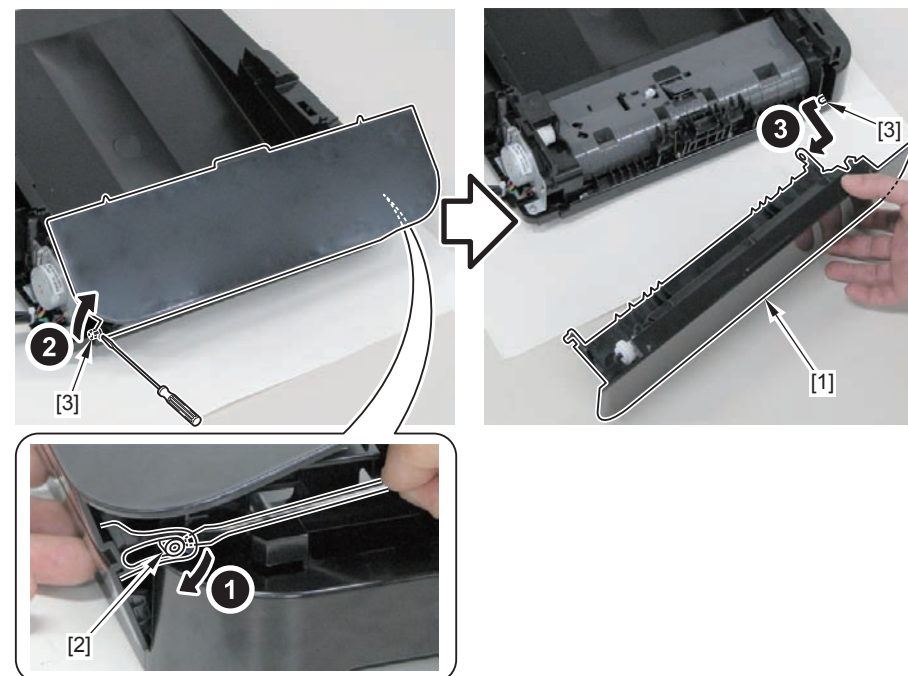

F-4-138

Removing the SADF Pickup Unit



F-4-139

Preparation

Duplex Model

- 1) Remove the Left Cover (Duplex Model) (Refer to page 4-86).
- 2) Remove the SADF Unit + Reader Unit (Refer to page 4-51).
- 3) Separate the SADF Unit and the Reader Unit (Refer to page 4-54).
- 4) Remove the SADF Upper Cover Unit (Refer to page 4-56).

Sinplex Model

- 1) Remove the Left Cover (Sinplex Model)(Refer to page 4-144).
- 2) Remove the SADF Unit + Reader Unit (Refer to page 4-51).
- 3) Separate the SADF Unit and the Reader Unit (Refer to page 4-54).
- 4) Remove the SADF Upper Cover Unit (Refer to page 4-56).

Procedure

CAUTION:

Do not damage the White Guide Plate [1].

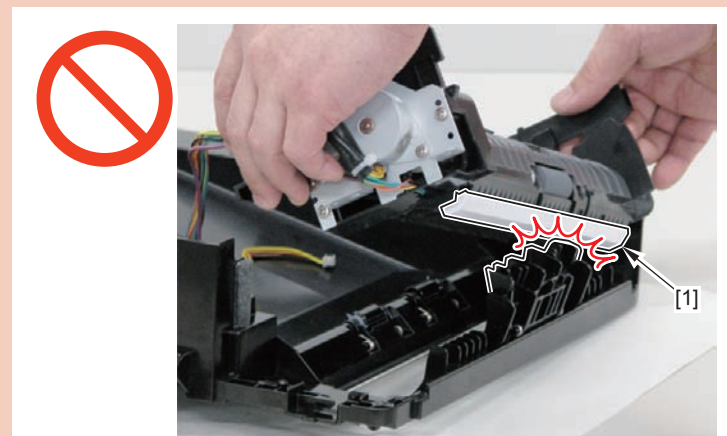

F-4-140

- 1) Remove the SADF Pickup Unit [1].

- 5 Screws (B Tightening) [2]
- Guide [A]

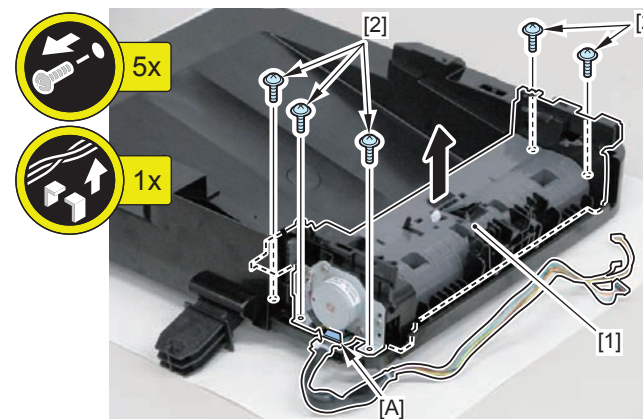

F-4-141

Removing the SADF Motor



F-4-142

Preparation

Duplex Model

- 1) Remove the Left Cover (Duplex Model) (Refer to page 4-86).
- 2) Remove the SADF Unit + Reader Unit (Refer to page 4-51).
- 3) Separate the SADF Unit and the Reader Unit (Refer to page 4-54).

Sinplex Model

- 1) Remove the Left Cover (Sinplex Model)(Refer to page 4-144).
- 2) Remove the SADF Unit + Reader Unit (Refer to page 4-51).
- 3) Separate the SADF Unit and the Reader Unit (Refer to page 4-54).

Procedure

- 1) Open the SADF Pickup Auxiliary Tray [1] and the SADF Upper Cover Unit [2].

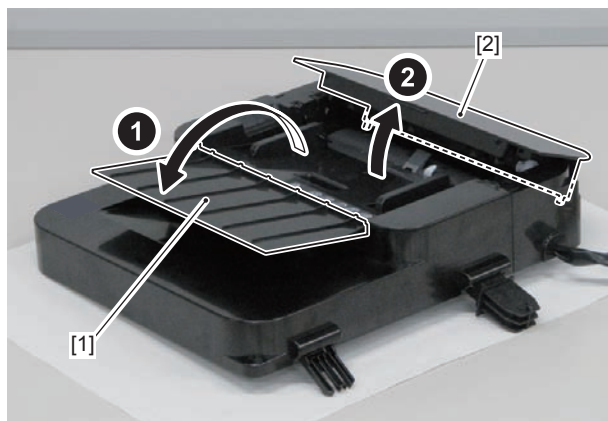

F-4-143

- 2) Remove the SADF Rear Cover [1].

- 3 Claws [2]

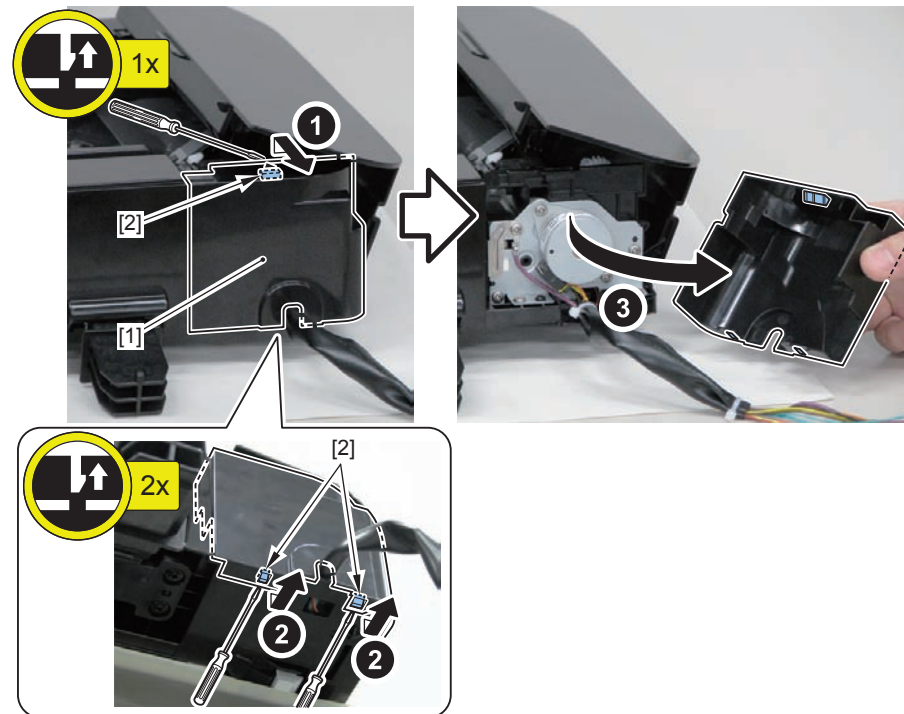

F-4-144

3) Remove the SADF Motor [1].

- 2 Screws [2]
- 2 Harness Bands [3]

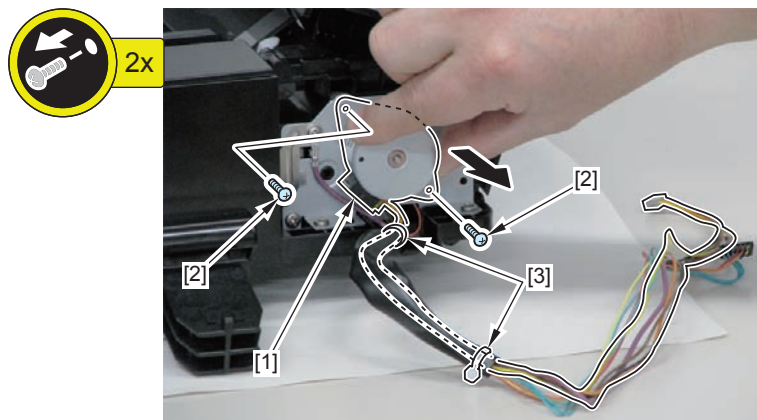

F-4-145

Removing the SADF Pickup Roller Unit

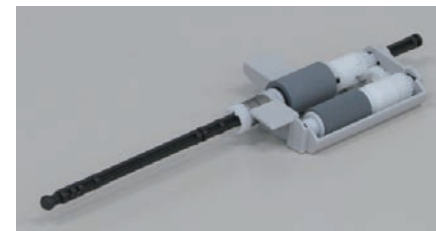

F-4-146

Preparation

● Duplex Model

- 1) Remove the Left Cover (Duplex Model) (Refer to page 4-86).
- 2) Remove the SADF Unit + Reader Unit (Refer to page 4-51).
- 3) Separate the SADF Unit and the Reader Unit (Refer to page 4-54).
- 4) Remove the SADF Upper Cover Unit (Refer to page 4-56).

● Simplex Model

- 1) Remove the Left Cover (Simplex Model) (Refer to page 4-144).
- 2) Remove the SADF Unit + Reader Unit (Refer to page 4-51).
- 3) Separate the SADF Unit and the Reader Unit (Refer to page 4-54).
- 4) Remove the SADF Upper Cover Unit (Refer to page 4-56).

Procedure

1) Remove the SADF Upper Cover [1].

- 1 Screw (B Tightening) [2]
- 1 Claw [3]
- 5 Hooks [4]

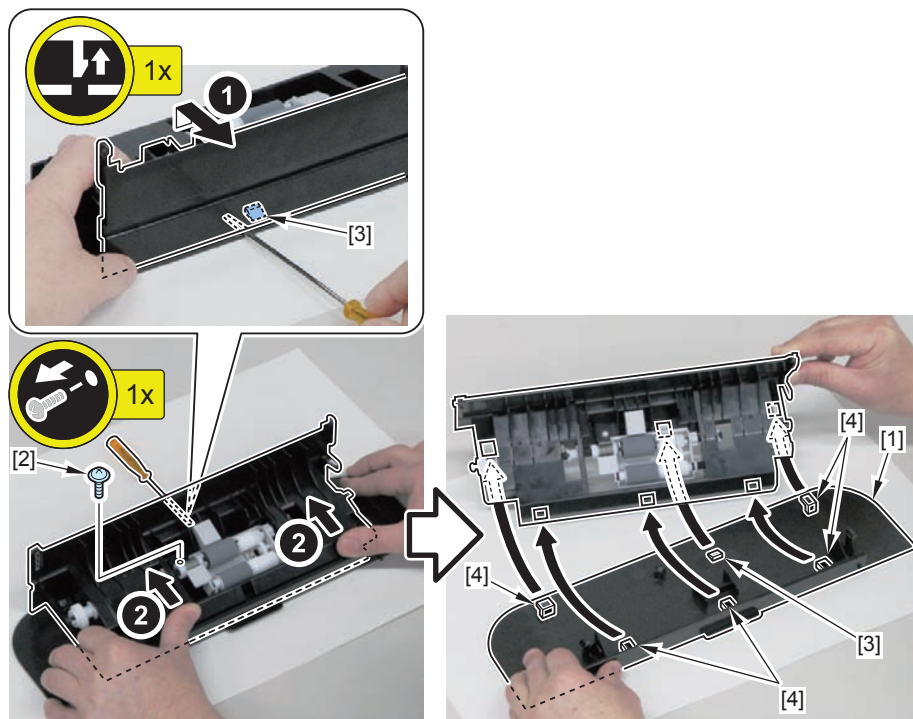

F-4-147

2) Remove the gear [1].

- 1 Claw [2]

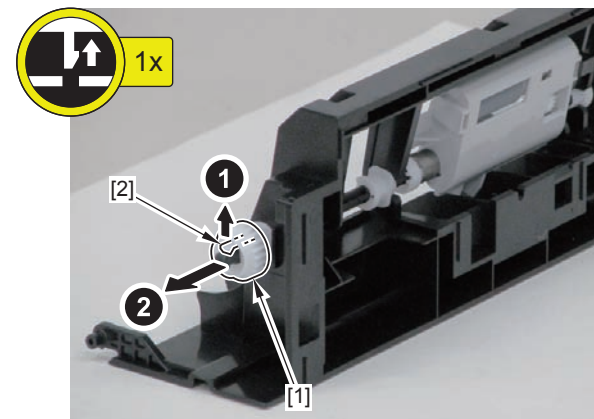

F-4-148

3) Remove the 2 E-rings [1] and the 2 bushings [2].

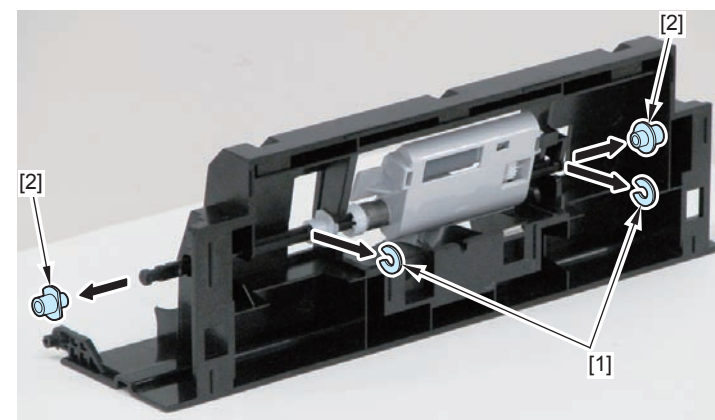

F-4-149

4) Move the bushing [1], and remove the Pickup Roller [2].

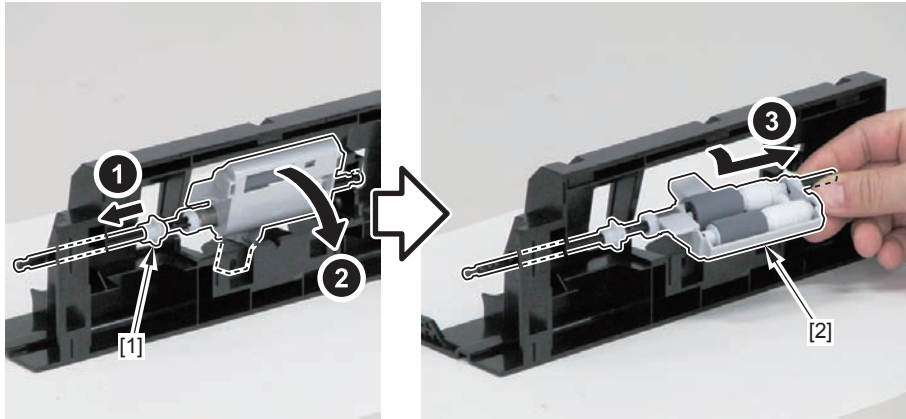

F-4-150

5) Remove the spring [1] and the bushing [2] from the Pickup Roller Unit.

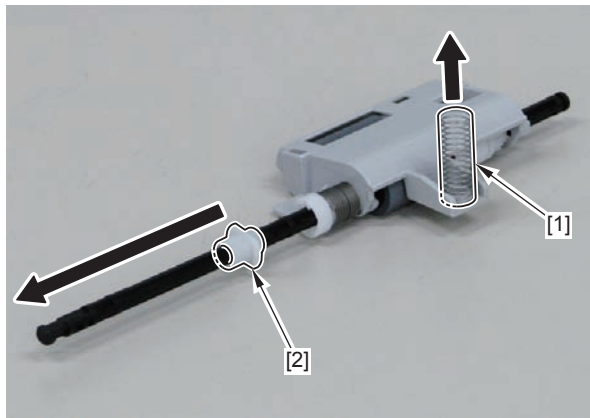

F-4-151

NOTE: How to assemble the SADF Pickup Roller Unit

1) Assemble it by aligning the spring [1] with the boss [2].

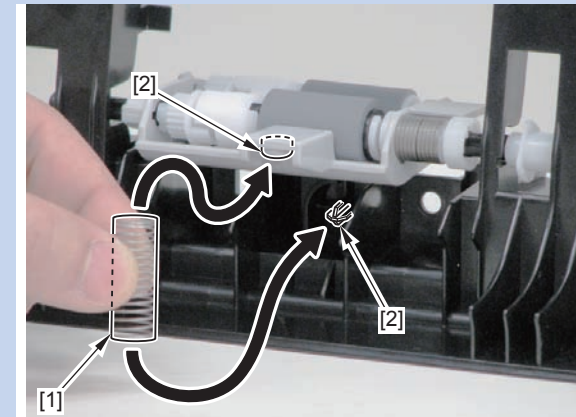

F-4-152

2) Be sure to align the orientation of the edge [A] of the 2 bushings [1] in the vertical direction.

- 1 E-ring [2]

3) Be sure to align the gear [3] with the D-cut [B] of the Pickup Roller Shaft.

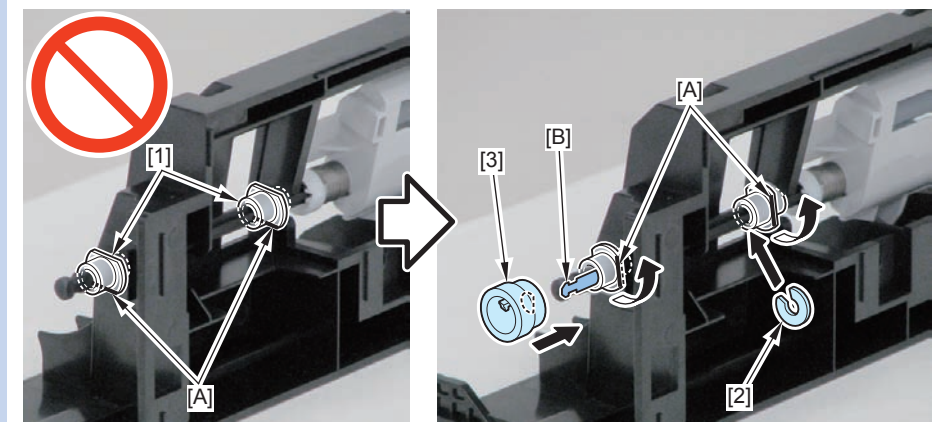

F-4-153

Removing the SADF Separation Pad



F-4-154

Preparation

Duplex Model

- 1) Remove the Left Cover (Duplex Model) (Refer to page 4-86).
- 2) Remove the SADF Unit + Reader Unit (Refer to page 4-51).
- 3) Separate the SADF Unit and the Reader Unit (Refer to page 4-54).
- 4) Remove the SADF Upper Cover Unit (Refer to page 4-56).

Sinplex Model

- 1) Remove the Left Cover (Sinplex Model)(Refer to page 4-144).
- 2) Remove the SADF Unit + Reader Unit (Refer to page 4-51).
- 3) Separate the SADF Unit and the Reader Unit (Refer to page 4-54).
- 4) Remove the SADF Upper Cover Unit (Refer to page 4-56).

Procedure

CAUTION:

- Do not touch the surface of the Separation Pad.
- Do not lose the spring [3] on the back side of the Separation Pad.

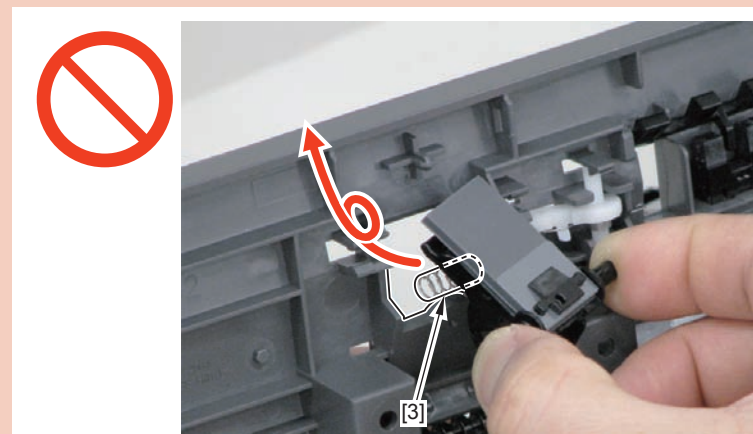

F-4-155

- 1) Remove the SADF Pickup Guide Unit [1].

- 4 Screws (B Tightening) [2]

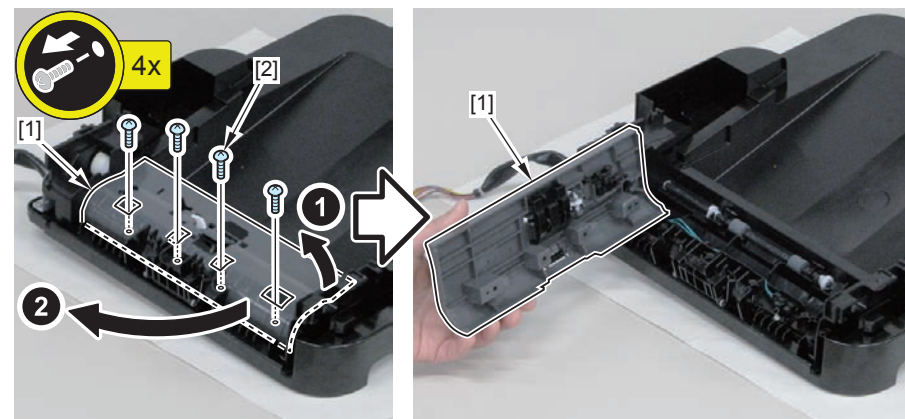

F-4-156

2) Release the 2 claws [2] of the Separation Pad [1].

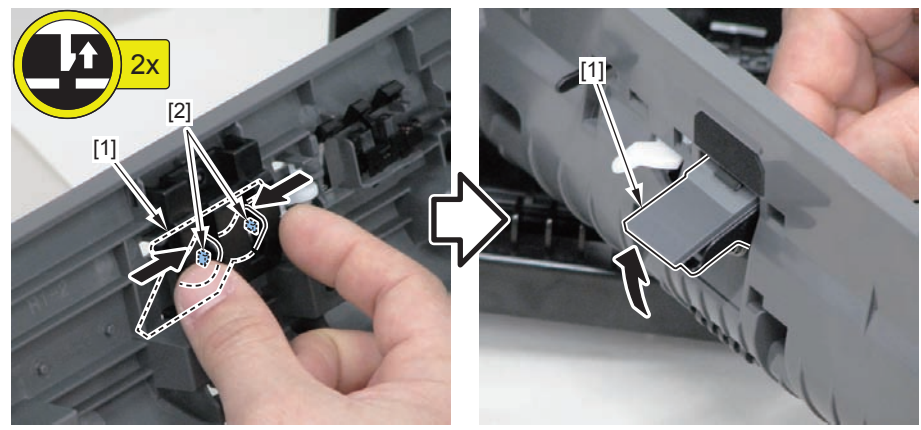

F-4-157

3) Remove the Separation Pad Holder [1].

- 2 Claws [2]
- 2 Hooks [3]

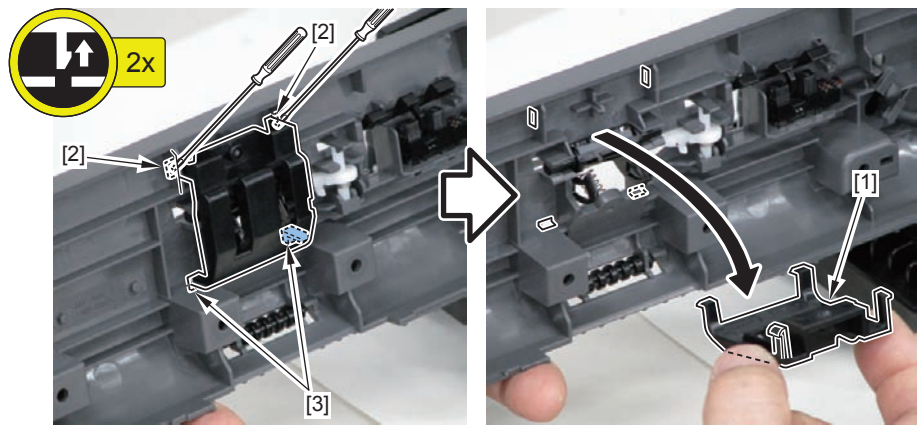

F-4-158

4) Remove the Separation Pad [1].

- 2 Shafts [2]

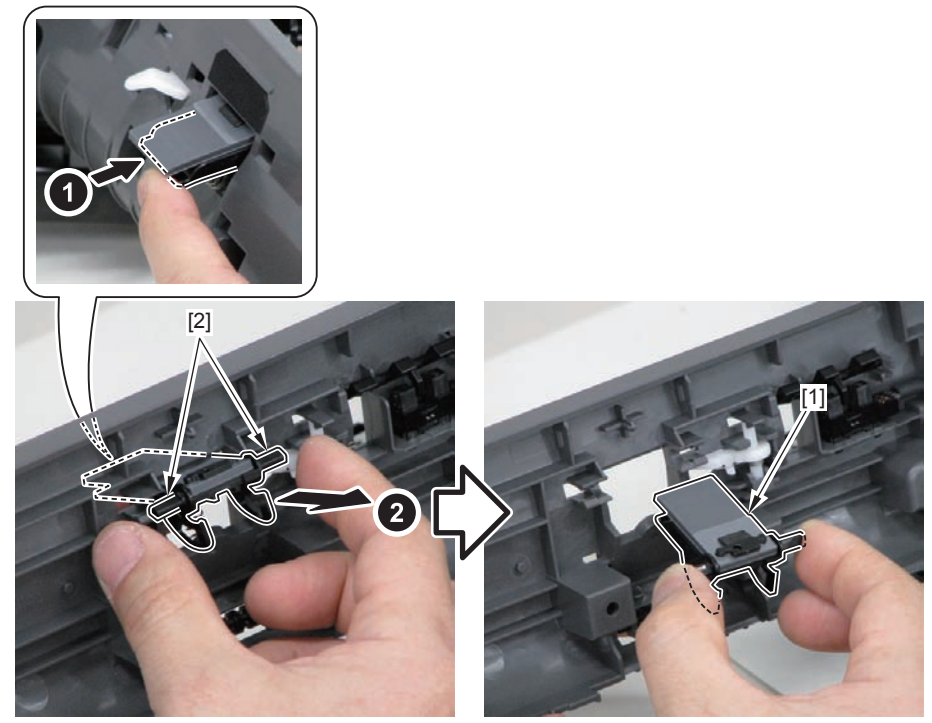

F-4-159

NOTE: How to assemble the Separation Pad

- 1) Insert the spring [1] into the boss [2].

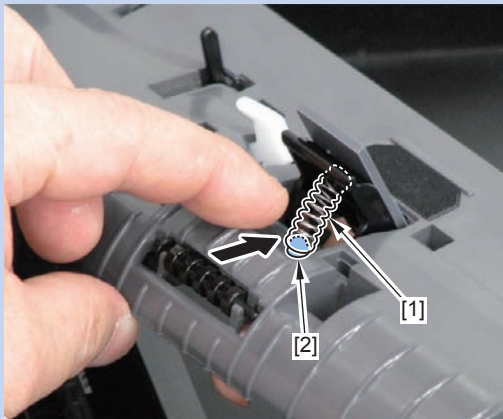

F-4-160

- 2) Install the SADF Separation Pad Cover [1].

- 2 Hooks [2]
- 2 Claws [3]

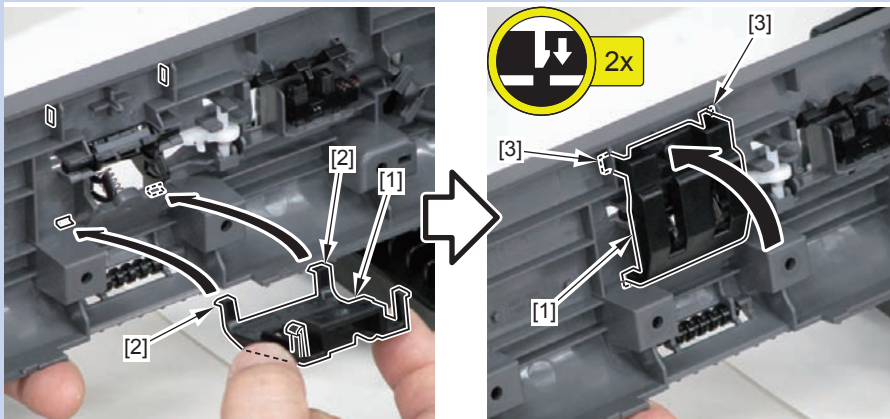

F-4-161

NOTE: How to assemble the Separation Pad

- 3) Assemble it by pressing the SADF Separation Pad [1] and hooking the claw [2].

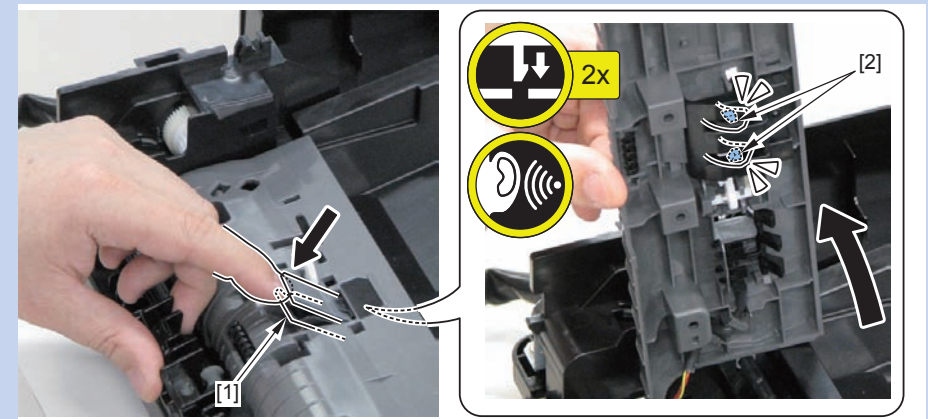

F-4-162

Removing the Copyboard Glass (SADF Model)

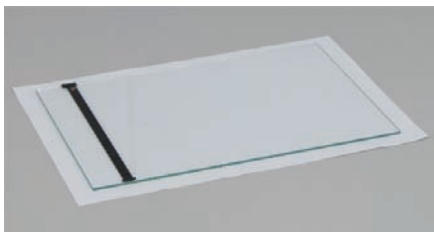

F-4-163

Preparation

Duplex Model

- 1) Remove the Left Cover (Duplex Model) (Refer to page 4-86).
- 2) Remove the SADF Unit + Reader Unit (Refer to page 4-51).
- 3) Separate the SADF Unit and the Reader Unit (Refer to page 4-54).

Sinplex Model

- 1) Remove the Left Cover (Sinplex Model)(Refer to page 4-144).
- 2) Remove the SADF Unit + Reader Unit (Refer to page 4-51).
- 3) Separate the SADF Unit and the Reader Unit (Refer to page 4-54).

Procedure

CAUTION:

- Be sure to place the removed Copyboard Glass on a cloth, etc. to avoid damaging the bottom sheet.
- When removing the Copyboard Glass, be careful not to touch the glass surface.
- If the surface becomes dirty, clean it with lint free paper.



F-4-164

- 1) Remove the 2 screws [1].

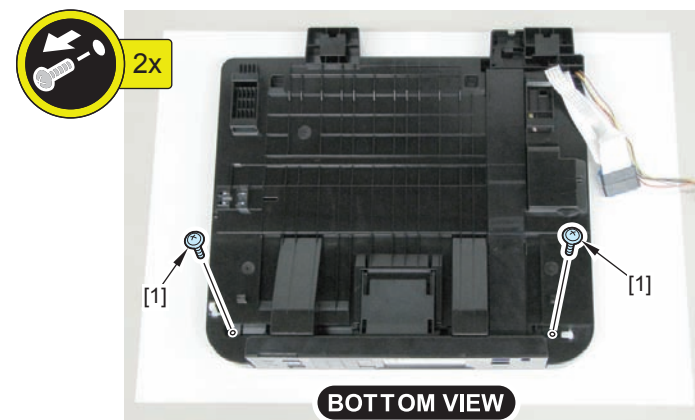

F-4-165

2) Remove the Copyboard Guide Holder [1].

- 1 Claw [2]
- 1 Hook [3]

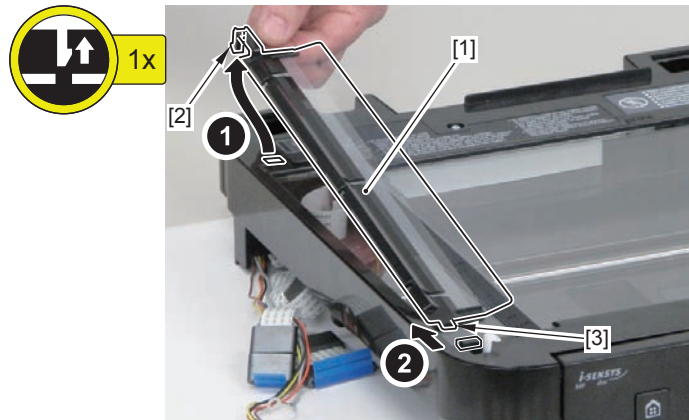

F-4-166

3) Remove the Reader Upper Cover Unit [1].

- 2 Screws [2]
- 5 Claws A [3]
- 1 Claw B [4]

NOTE:

The following shows the 5 claws A [3] and the claw B [4] of the Reader Upper Cover Unit.

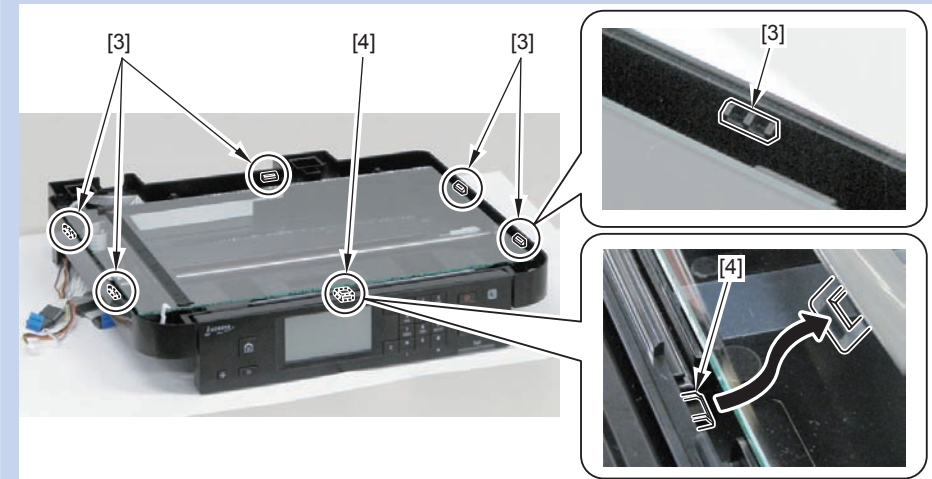

F-4-167

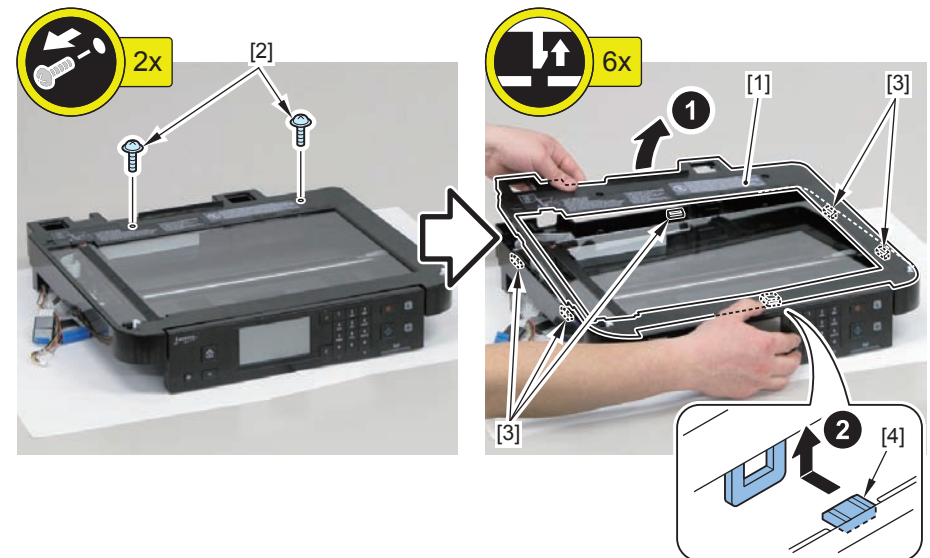

F-4-168

4) Remove the Copyboard Glass [1].

CAUTION:

- Do not lose the 2 spacers [1] of the Contact Image Sensor Unit.
- Do not touch the document reading part [A] of the Contact Image Sensor Unit.

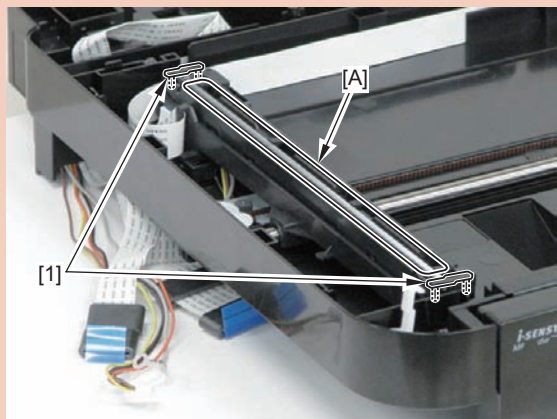

F-4-169

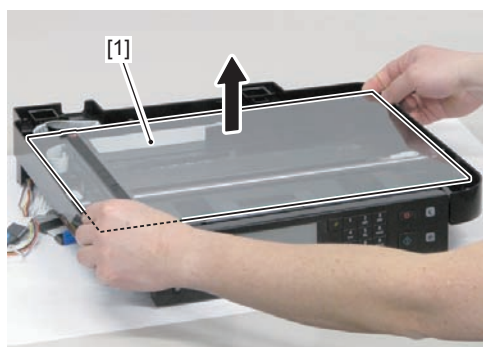

F-4-170

● Removing the Contact Image Sensor (SADF Model)



F-4-171

■ Preparation

● Duplex Model

- 1) Remove the Left Cover (Duplex Model) (Refer to page 4-86).
- 2) Remove the SADF Unit + Reader Unit (Refer to page 4-51).
- 3) Separate the SADF Unit and the Reader Unit (Refer to page 4-54).
- 4) Remove the Copyboard Glass (SADF Model) (Refer to page 4-68).

● Simplex Model

- 1) Remove the Left Cover (Simplex Model) (Refer to page 4-144).
- 2) Remove the SADF Unit + Reader Unit (Refer to page 4-51).
- 3) Separate the SADF Unit and the Reader Unit (Refer to page 4-54).
- 4) Remove the Copyboard Glass (SADF Model) (Refer to page 4-68).

Procedure

CAUTION:

- Do not lose the 2 spacers [1] of the Contact Image Sensor Unit.
- Do not touch the document reading part [A] of the Contact Image Sensor Unit.

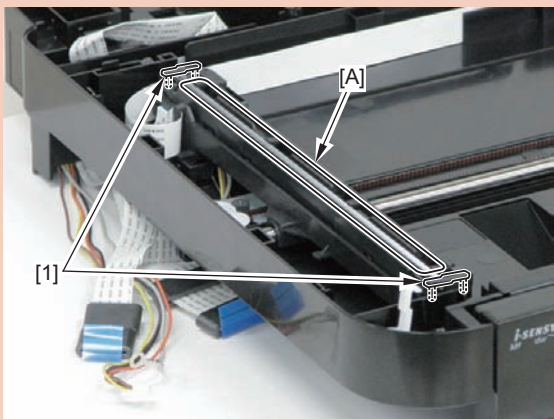

F-4-172

1) Move the Contact Image Sensor Unit [1].

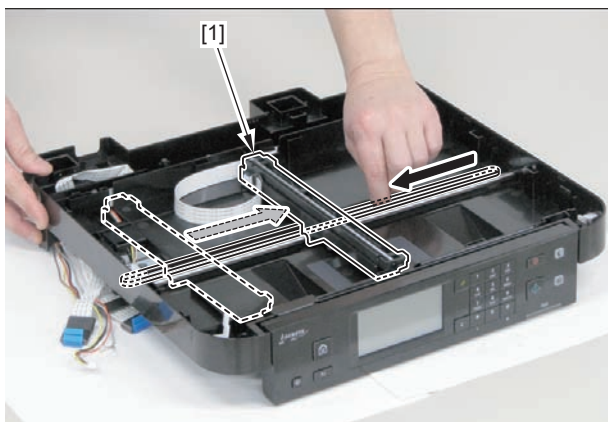

F-4-173

2) Remove the 2 spacers [1] and the Flat Cable [2].

- 1 Guide [A]

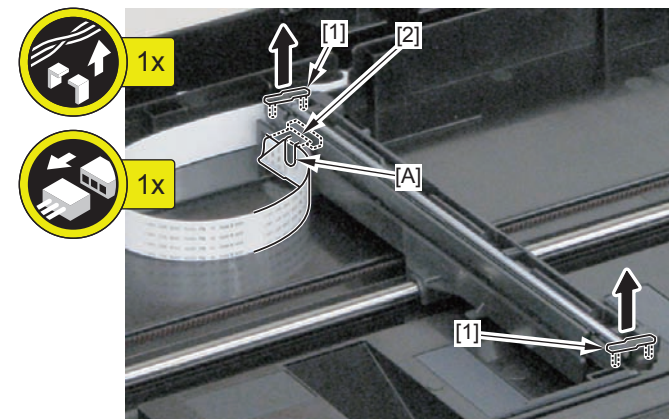

F-4-174

3) Remove the Contact Image Sensor [1].

- 2 Shafts [2]

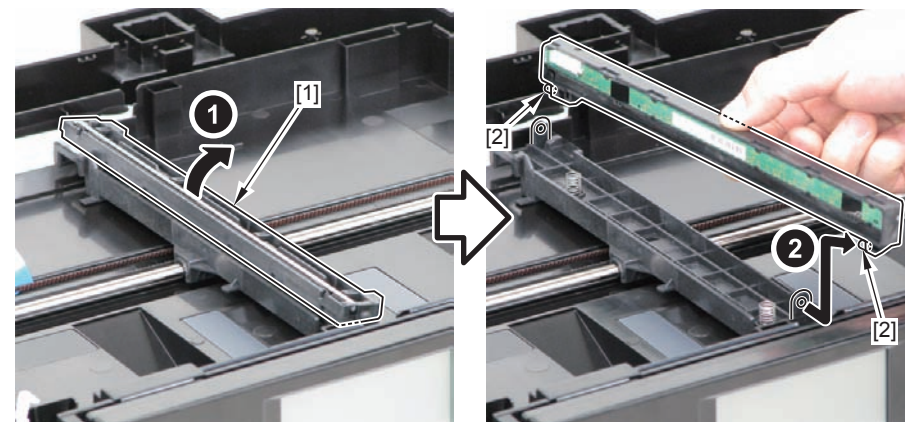

F-4-175

CAUTION:

If the Contact Image Sensor Unit comes off, be sure to put the tooth [1] of the belt in the groove [2] on the bottom of the Contact Image Sensor to install the unit.

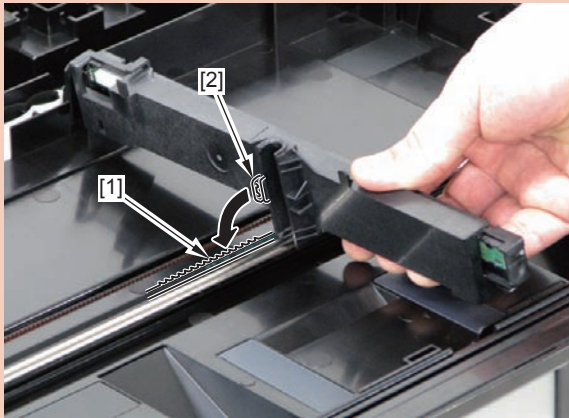

F-4-176

● Removing the Flat Bed Motor Unit (SADF Model)

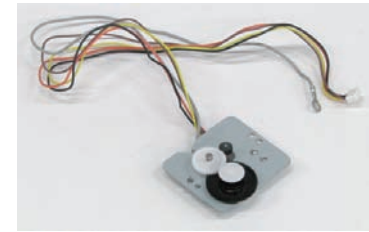

F-4-177

■ Preparation

● Duplex Model

- 1) Remove the Left Cover (Duplex Model) (Refer to page 4-86).
- 2) Remove the SADF Unit + Reader Unit (Refer to page 4-51).
- 3) Separate the SADF Unit and the Reader Unit (Refer to page 4-54).
- 4) Remove the Copyboard Glass (SADF Model) (Refer to page 4-68).

● Simplex Model

- 1) Remove the Left Cover (Simplex Model) (Refer to page 4-144).
- 2) Remove the SADF Unit + Reader Unit (Refer to page 4-51).
- 3) Separate the SADF Unit and the Reader Unit (Refer to page 4-54).
- 4) Remove the Copyboard Glass (SADF Model) (Refer to page 4-68).

Procedure

CAUTION:

- Do not lose the 2 spacers [1] of the Contact Image Sensor Unit.
- Do not touch the document reading part [A] of the Contact Image Sensor Unit.

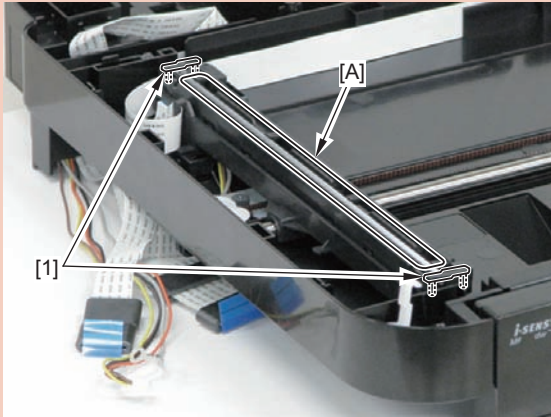

F-4-178

1) Move the Contact Image Sensor Unit [1].

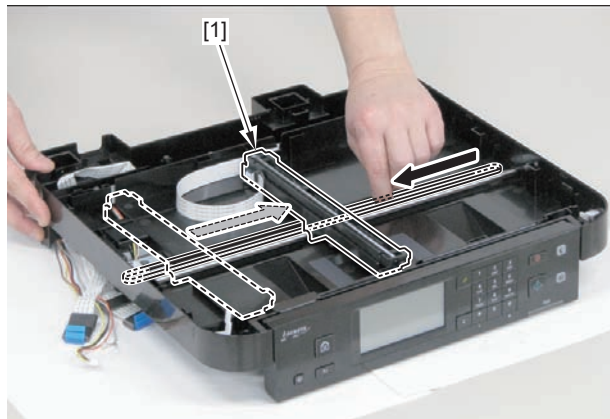

F-4-179

2) Press the gear [1] to bend the belt [2], and remove the belt [2] from the gear [3].

CAUTION:

Grease is applied on the shaft [4] of the Contact Image Sensor, so be careful not to let the belt [2] come in contact with the shaft.

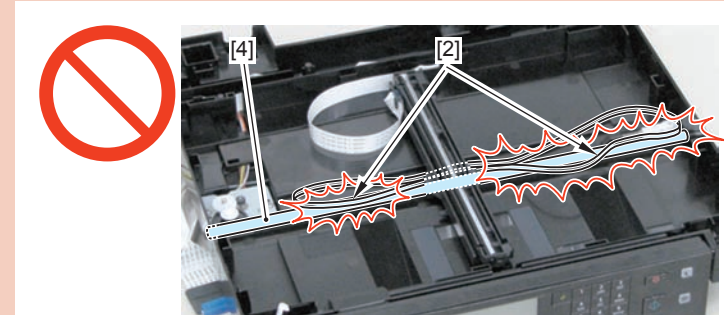

F-4-180

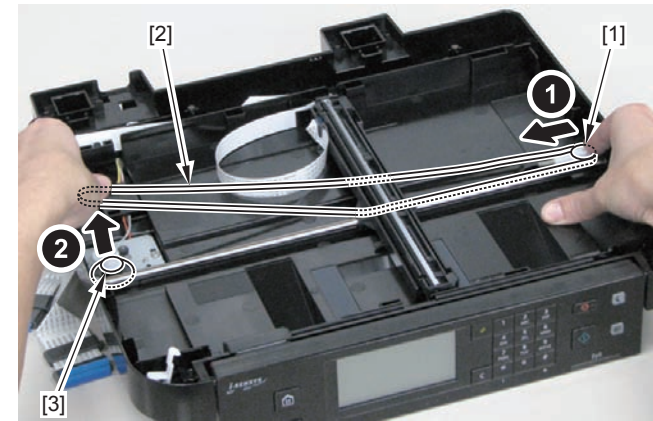

F-4-181

3) Remove the Guide Cover [1].

- 1 Claw [2]

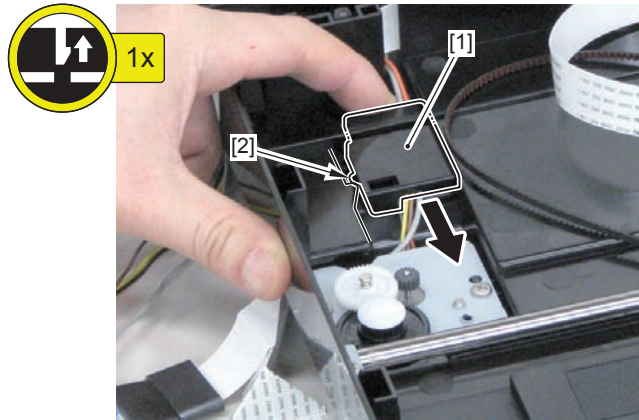

F-4-182

4) Free the harness [1] and the Grounding Wire [2] from the hole [A] of the Reader Unit and the Harness Guide [B].

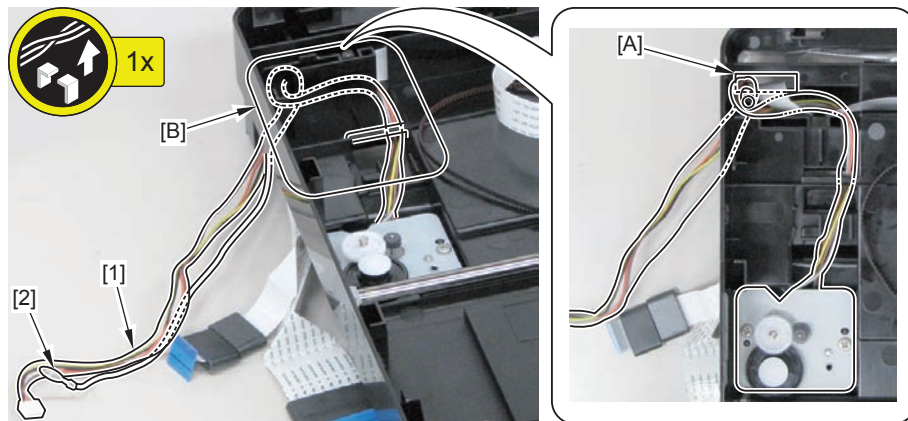

F-4-183

5) Remove the Flat Bed Motor Unit [1].

- 2 Screws [2]

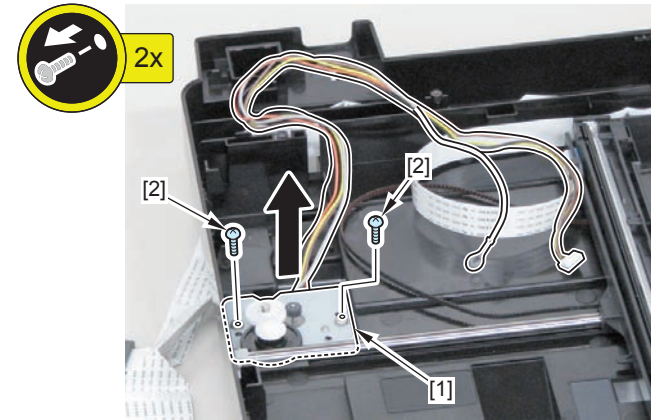

F-4-184

CAUTION:

If the Contact Image Sensor Unit comes off, be sure to put the tooth [1] of the belt in the groove [2] on the bottom of the Contact Image Sensor to install the unit.

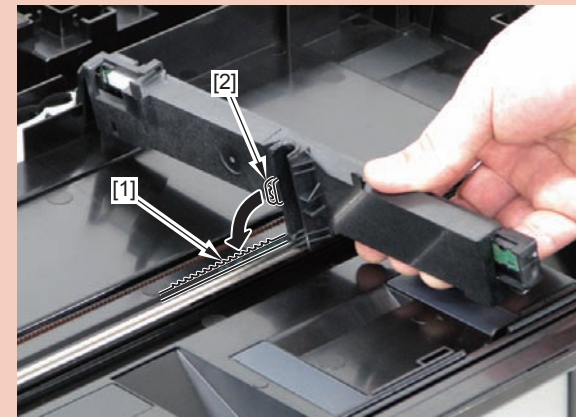

F-4-185

Original Exposure/Feed System (Copyboard Model)

Layout Drawing

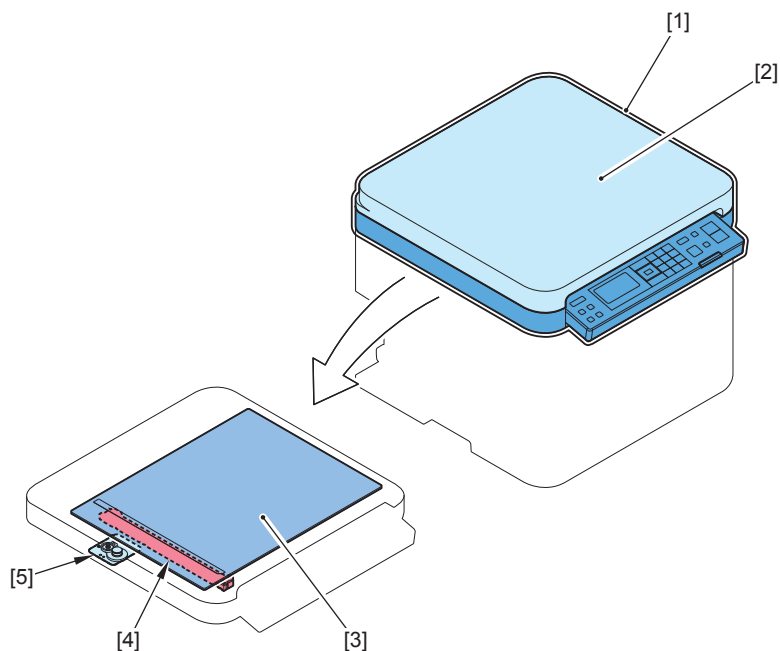

F-4-186

No.	Name	Reference	Remarks
[1]	Copyboard Covert and Reader Unit	(Refer to page 4-76)	
[2]	Copyboard Cover	(Refer to page 4-75)	
[3]	Copyboard Glass	(Refer to page 4-78)	
[4]	Contact Image Sensor	(Refer to page 4-80)	
[5]	Flatbed Motor Unit	(Refer to page 4-82)	

T-4-37

Removing the Copyboard Cover



F-4-187

Procedure

- 1) Remove the Copyboard Cover [1].
 - 2 Claws [2]

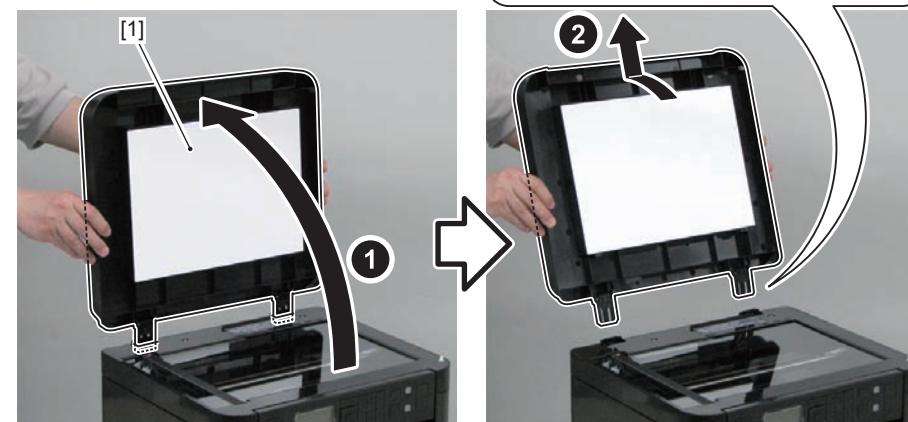
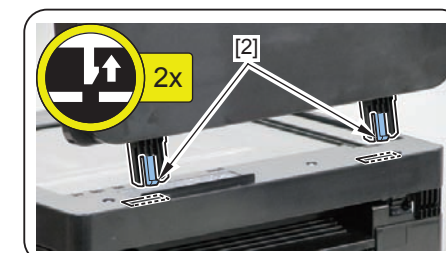

F-4-188

Removing the Copyboard Cover + Reader Unit



F-4-189

Preparation

Duplex Model

1) Remove the Left Cover (Duplex Model) (Refer to page 4-86).

Sinplex Model

1) Remove the Left Cover (Sinplex Model)(Refer to page 4-144).

Procedure

1) Disconnect the terminal [1] and the 3 connectors [4] of the Grounding Wire, and free the Grounding Wire and the harness [5] from the Harness Guide [A].

- 1 Screw (black TP) [2]
- 1 Wire Saddle [3]

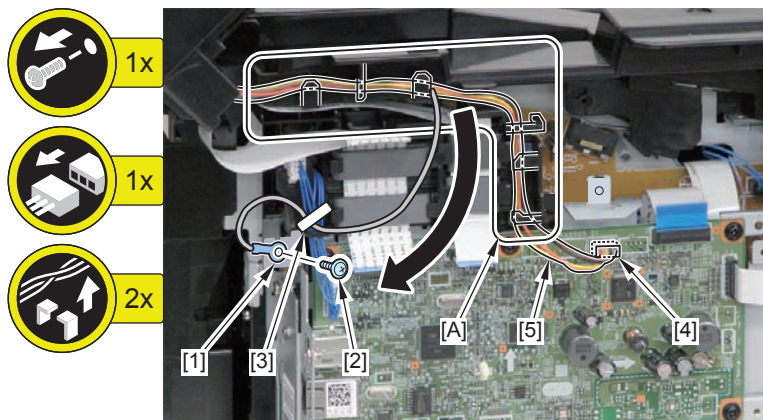

F-4-190

2) Free the 2 Flat Cables [1] from the Harness Guide [A].

- 4 Ferrite Cores [2]
- 4 Claws [3]

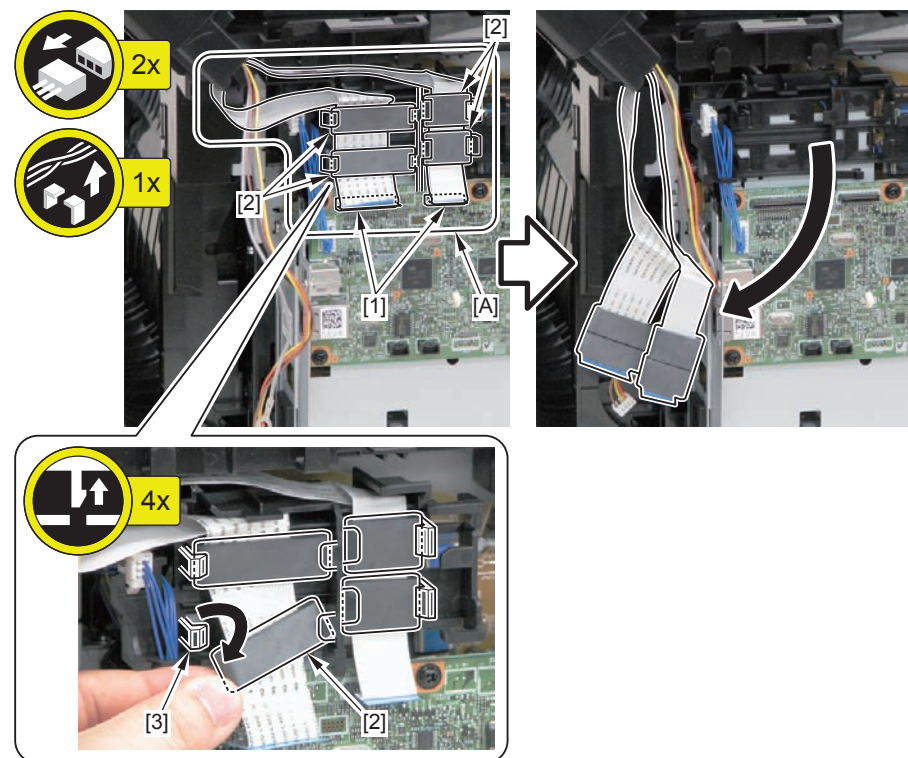

F-4-191

3) Remove the Copyboard Cover + Reader Unit [1].

- 2 Claws [2]

CAUTION:

- Be sure to install/remove the unit carefully so as not to damage the Flat Cable [3] and harness [4] with the [A] part.

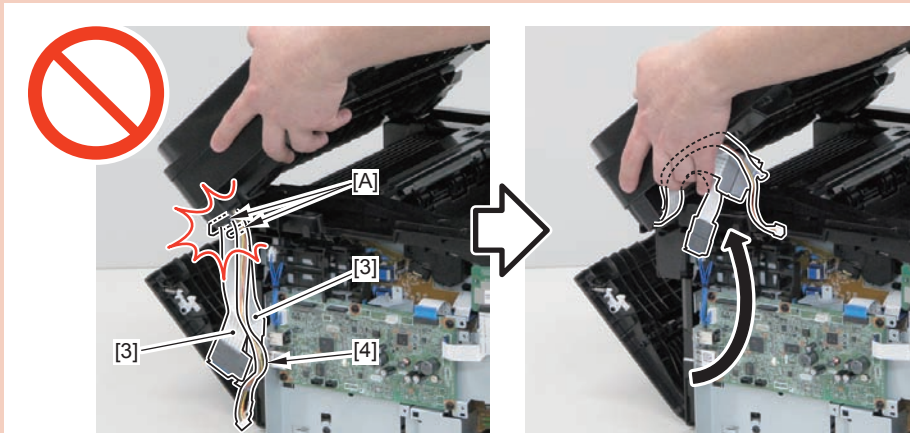

F-4-192

- Be sure to place the unit so as not to damage the Flat Cable [3] and harness [4].

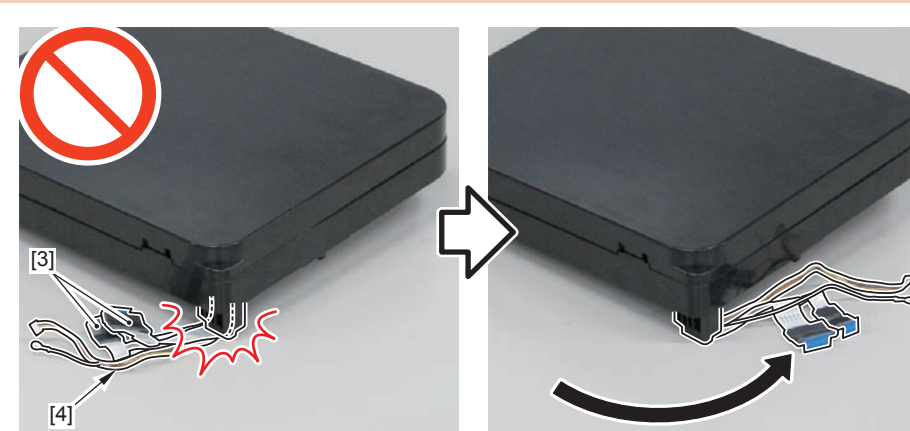

F-4-193

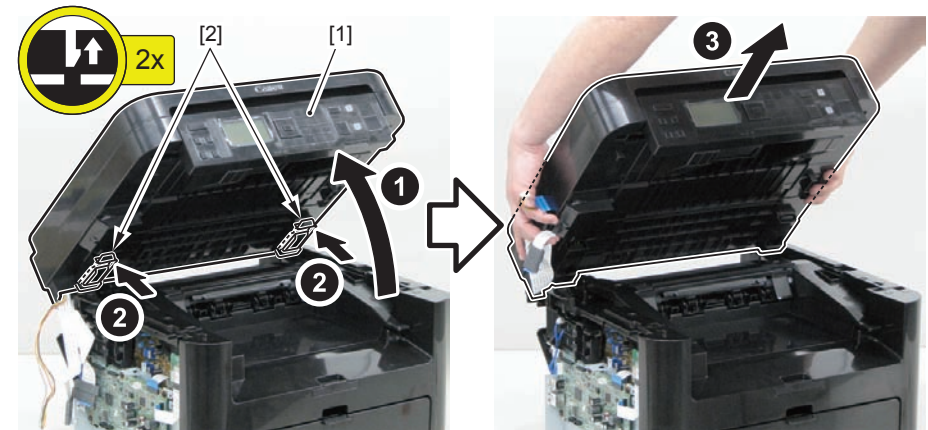

F-4-194

NOTE: How to assemble the Reader Unit

Be sure to secure the 2 claws [1] of the Hinge Arm to the 2 hooks [2] of the Reader Unit.

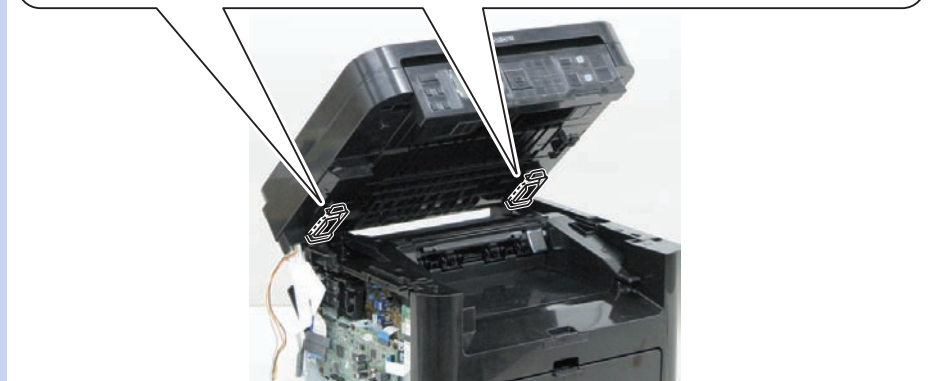
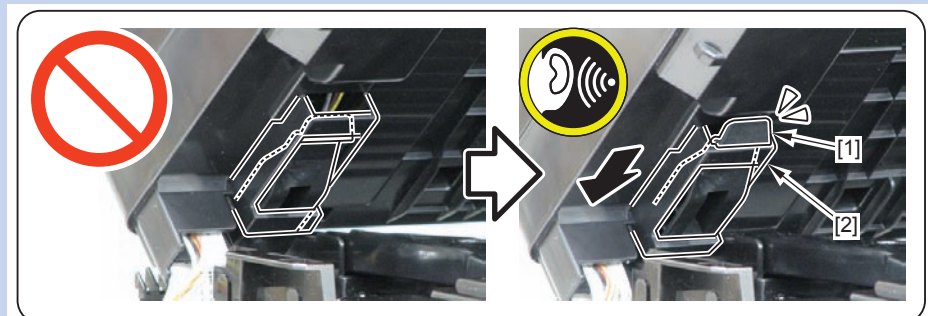

F-4-195

NOTE:

The following shows how to route the harness.

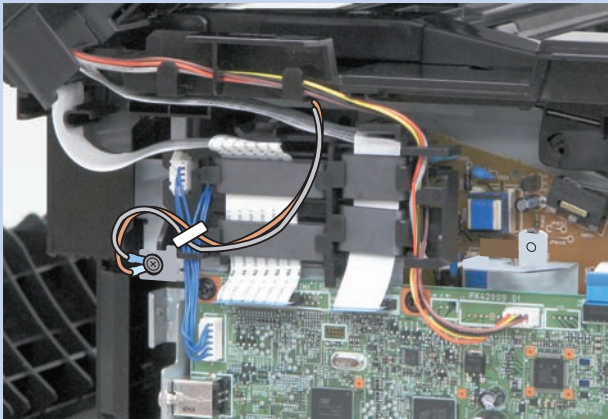

F-4-196

Removing the Copyboard Glass (Copyboard Model)

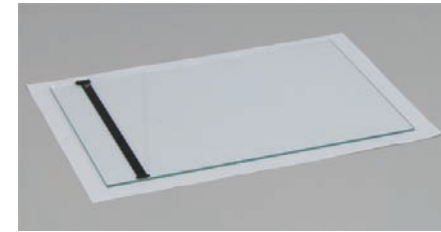

F-4-197

Preparation

- 1) Remove the Copyboard Cover (Refer to page 4-75).

Procedure

CAUTION:

- Be sure to place the removed Copyboard Glass on a cloth, etc. to avoid damaging the bottom sheet.
- When removing the Copyboard Glass, be careful not to touch the glass surface.
- If the surface becomes dirty, clean it with lint free paper.



F-4-198

1) Remove the 2 screws [1].

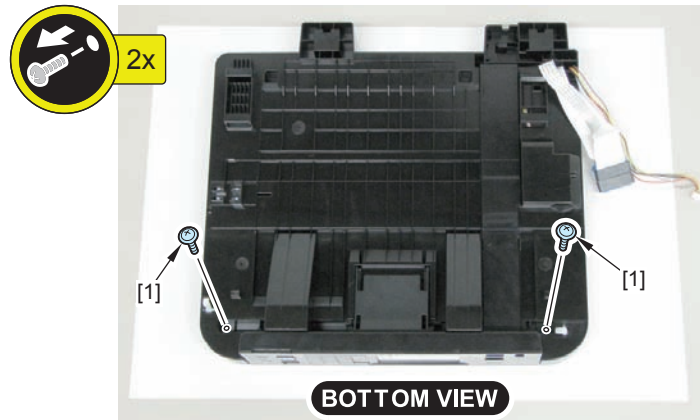

F-4-199

2) Remove the Copyboard Guide Holder [1].

- 1 Claw [2]
- 1 Hook [3]

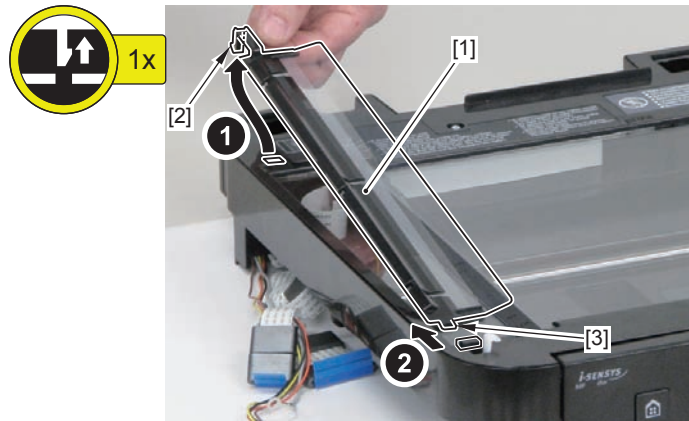

F-4-200

3) Remove the Reader Upper Cover Unit [1].

- 2 Screws [2]
- 5 Claws A [3]
- 1 Claw B [4]

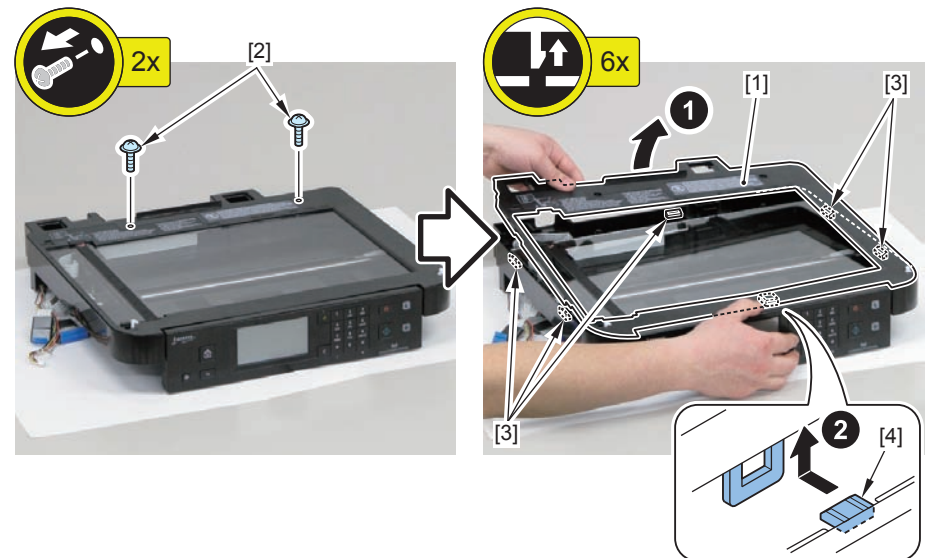

F-4-202

NOTE:

The following shows the 5 claws A [3] and the claw B [4] of the Reader Upper Cover Unit.

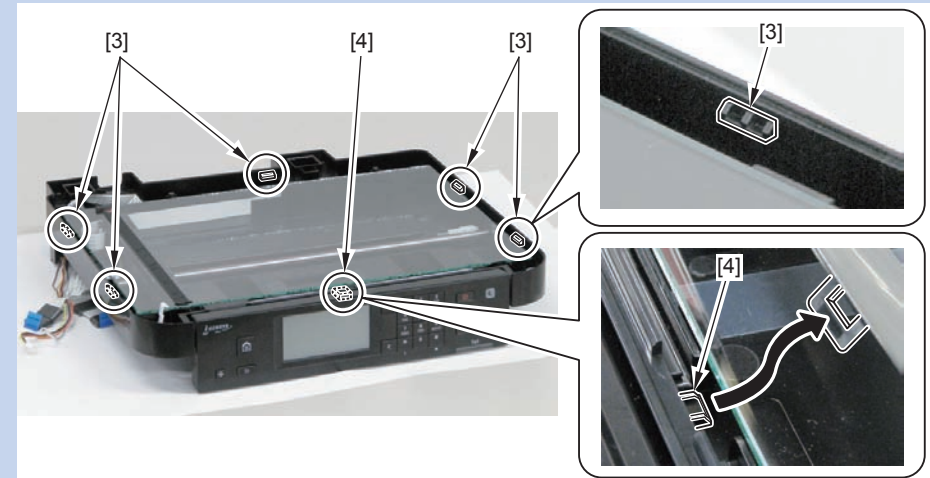

F-4-201

4) Remove the Copyboard Glass [1].

CAUTION:

- Do not lose the 2 spacers [1] of the Contact Image Sensor Unit.
- Do not touch the document reading part [A] of the Contact Image Sensor Unit.

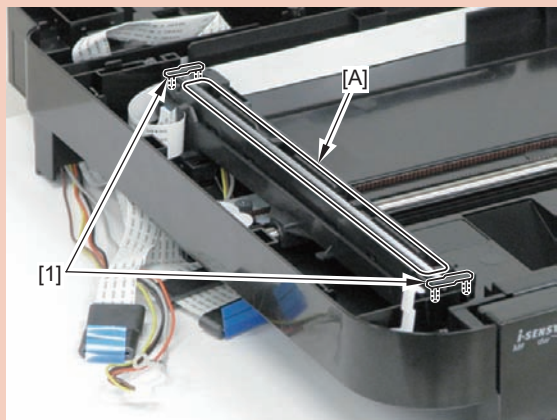

F-4-203

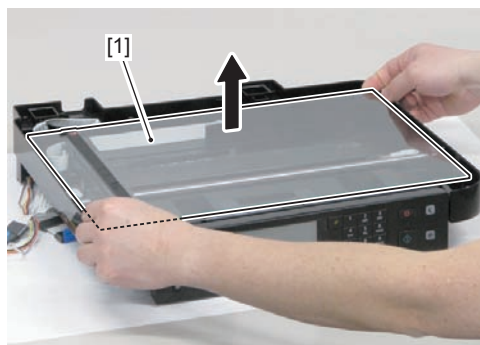

F-4-204

Removing the Contact Image Sensor (Copyboard Model)



F-4-205

Preparation

- 1) Remove the Copyboard Cover (Refer to page 4-75).
- 2) Remove the Copyboard Glass (Copyboard Model) (Refer to page 4-78).

Procedure

CAUTION:

- Do not lose the 2 spacers [1] of the Contact Image Sensor Unit.
- Do not touch the document reading part [A] of the Contact Image Sensor Unit.

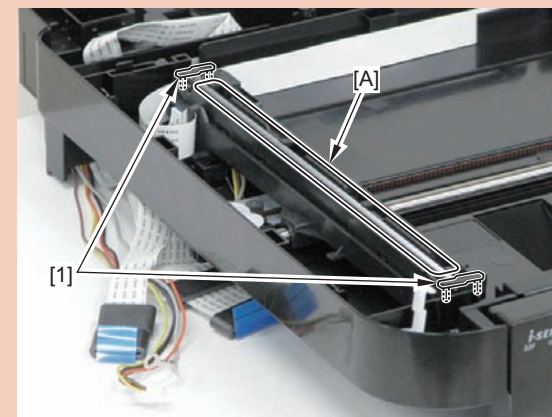

F-4-206

1) Move the Contact Image Sensor Unit [1].

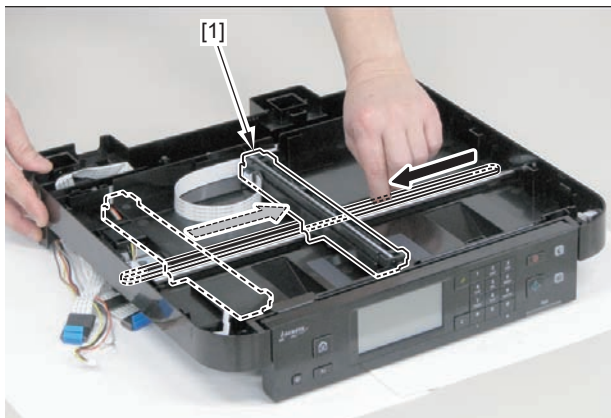

F-4-207

2) Remove the 2 spacers [1] and the Flat Cable [2].

• 1 Guide [A]

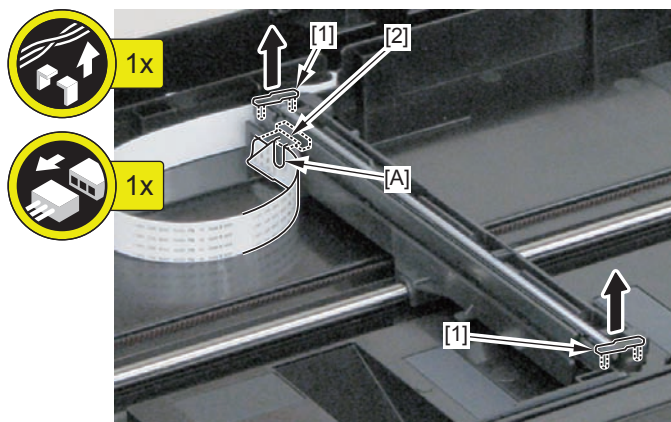

F-4-208

3) Remove the Contact Image Sensor [1].

• 2 Shafts [2]

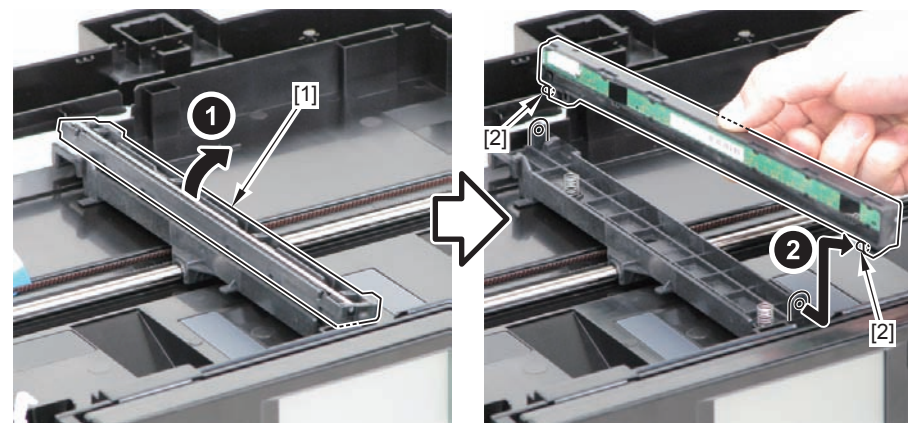

F-4-209

CAUTION:

If the Contact Image Sensor Unit comes off, be sure to put the tooth [1] of the belt in the groove [2] on the bottom of the Contact Image Sensor to install the unit.

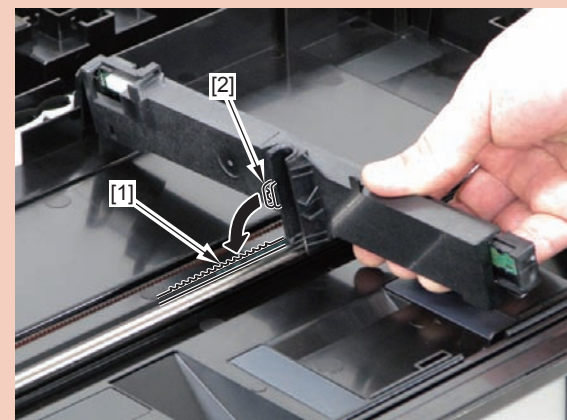

F-4-210

● Removing the Flat Bed Motor Unit (Copyboard Model)

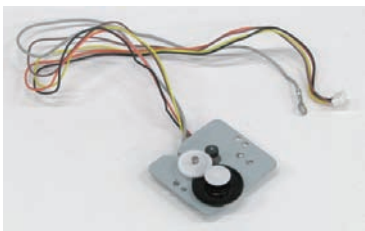

F-4-211

■ Preparation

● Duplex Model

- 1) Remove the Left Cover (Duplex Model) (Refer to page 4-86).
- 2) Removing the Copyboard Cover + Reader Unit (Refer to page 4-76).
- 3) Remove the Copyboard Cover (Refer to page 4-75).
- 4) Remove the Copyboard Glass (Copyboard Model) (Refer to page 4-78).

● S simplex Model

- 1) Remove the Left Cover (Simplex Model)(Refer to page 4-144).
- 2) Removing the Copyboard Cover + Reader Unit (Refer to page 4-76).
- 3) Remove the Copyboard Cover (Refer to page 4-75).
- 4) Remove the Copyboard Glass (Copyboard Model) (Refer to page 4-78).

■ Procedure

CAUTION:

- Do not lose the 2 spacers [1] of the Contact Image Sensor Unit.
- Do not touch the document reading part [A] of the Contact Image Sensor Unit.

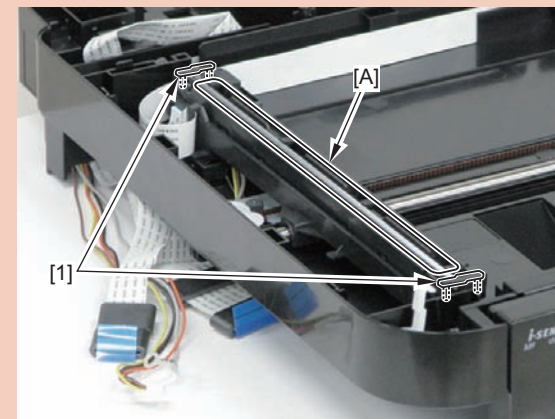

F-4-212

- 1) Move the Contact Image Sensor Unit [1].

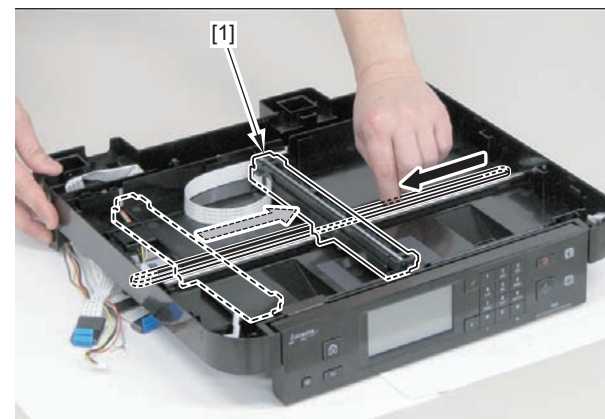

F-4-213

2) Press the gear [1] to bend the belt [2], and remove the belt [2] from the gear [3].

CAUTION:

Grease is applied on the shaft [4] of the Contact Image Sensor, so be careful not to let the belt [2] come in contact with the shaft.

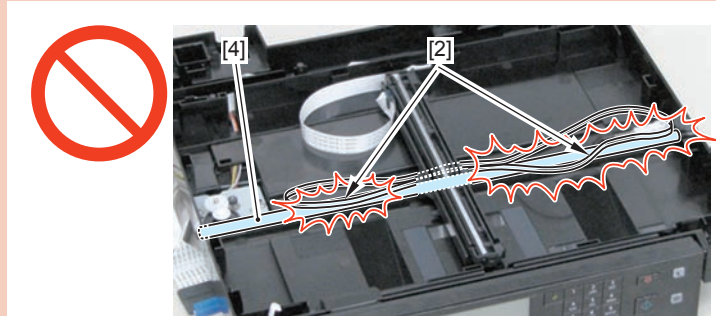

F-4-214

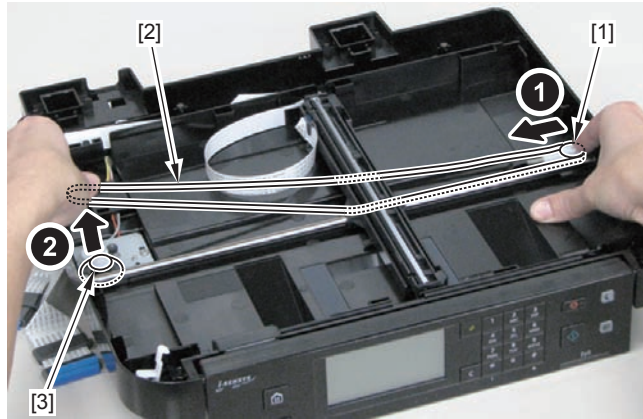

F-4-215

3) Remove the Guide Cover [1].

- 1 Claw [2]

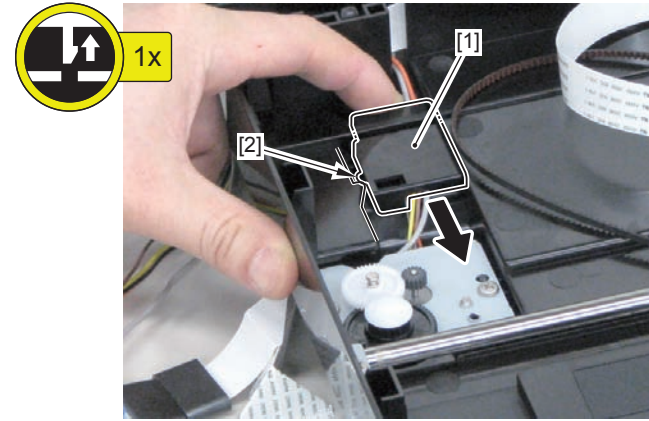

F-4-216

4) Free the harness [1] and the Grounding Wire [2] from the hole [A] of the Reader Unit and the Harness Guide [B].

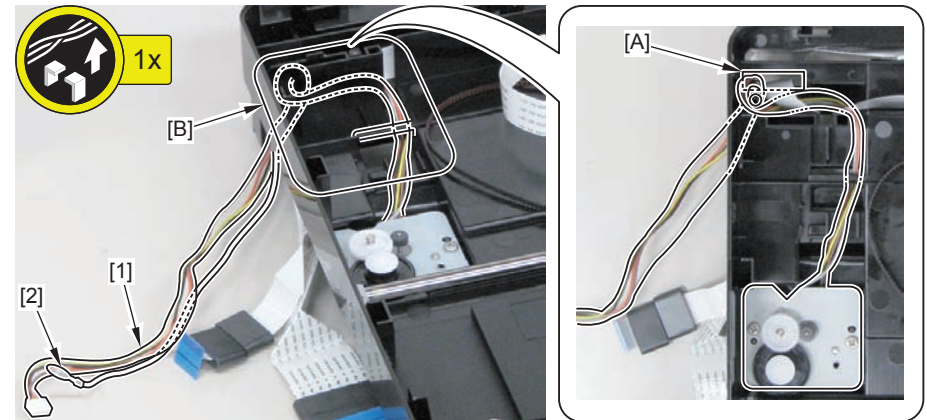

F-4-217

5) Remove the Flat Bed Motor Unit [1].

- 2 Screws [2]

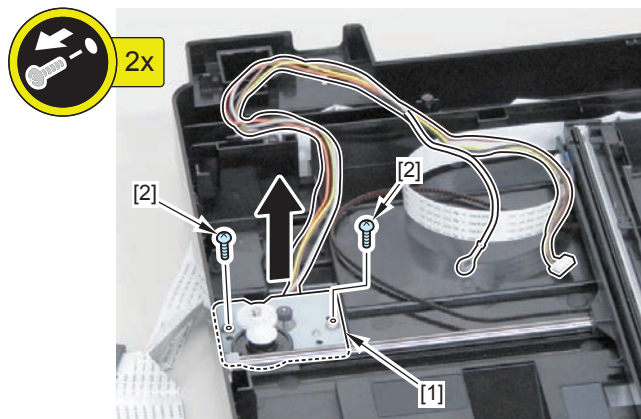

F-4-218

CAUTION:

If the Contact Image Sensor Unit comes off, be sure to put the tooth [1] of the belt in the groove [2] on the bottom of the Contact Image Sensor to install the unit.

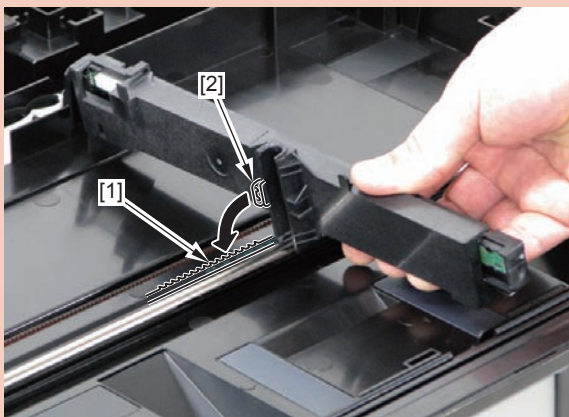

F-4-219

External Cover/Internal System (Duplex Model)

● Rear Side

● Layout Drawing

● Front Side

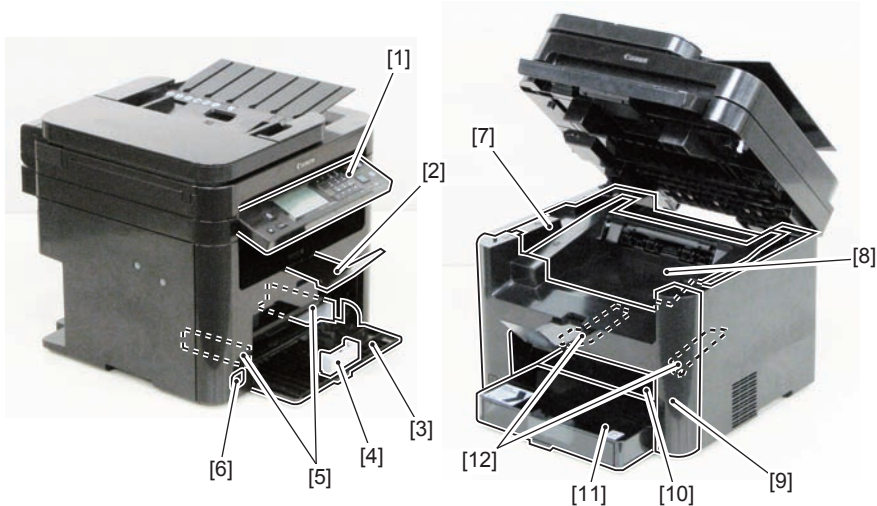

F-4-220

No.	Name	Reference	Remarks
[1]	Control Panel Unit	(Refer to page 4-93)	-
[2]	Delivery Auxiliary Tray		-
[3]	Pickup Tray		-
[4]	Trailing Edge Paper Guides		-
[5]	Pickup Tray Side Guide Plate		-
[6]	Power Switch		-
[7]	Upper Cover	(Refer to page 4-89)	-
[8]	Delivery Tray	(Refer to page 4-89)	-
[9]	Front Cover Unit	(Refer to page 4-89)	-
[10]	Multi-Purpose Tray		-
[11]	Tray Cover		-
[12]	Multi-Purpose Tray Side Guide Plate		-

T-4-38

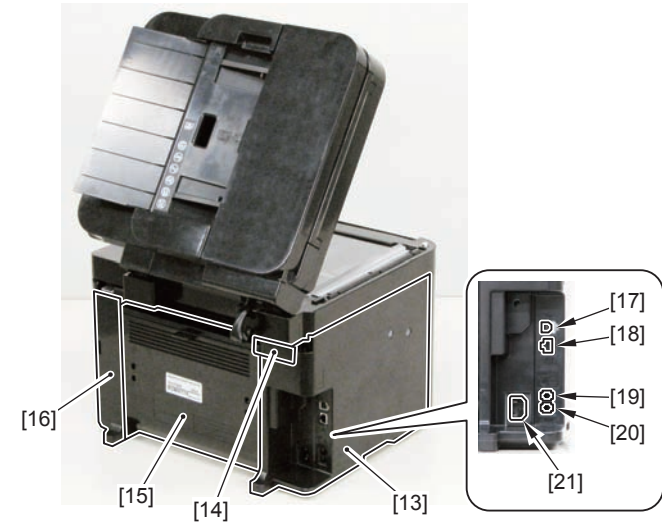

F-4-221

No.	Name	Reference	Remarks
[13]	Left Cover	(Refer to page 4-86)	-
[14]	Hinge Face Cover		-
[15]	Duplex Feed Guide Unit	(Refer to page 4-91)	-
[16]	Right Cover	(Refer to page 4-87)	-
[17]	USB Device Port		-
[18]	LAN Port		Model with NET
[19]	External Device Jack		Model with FAX
[20]	Telephon Line Jack		Model with FAX
[21]	Power Supply Cord Slot		-

T-4-39

Removing the Left Cover (Duplex Model)



F-4-222

Procedure

NOTE:

The following shows the 5 claws [1] and 3 hooks [2] of the Left Cover.

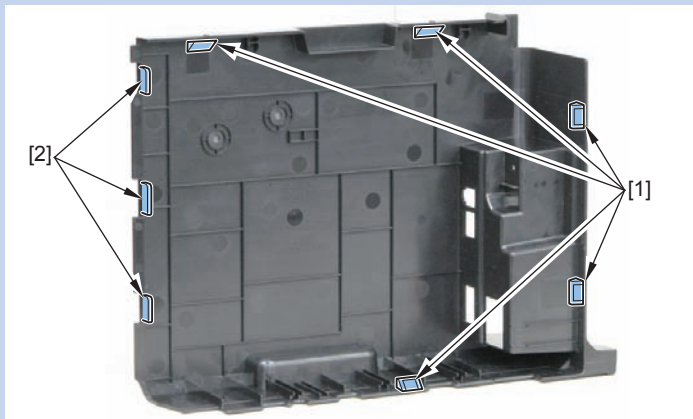

F-4-223

1) Open the Rear Cover [1], and remove the screw (black TP) [2].

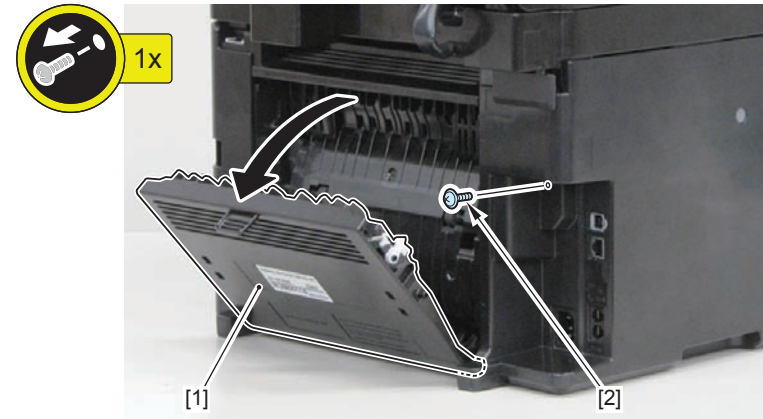

F-4-224

2) Release the 2 claws [1] at the rear side and the claw [2] at the lower side.

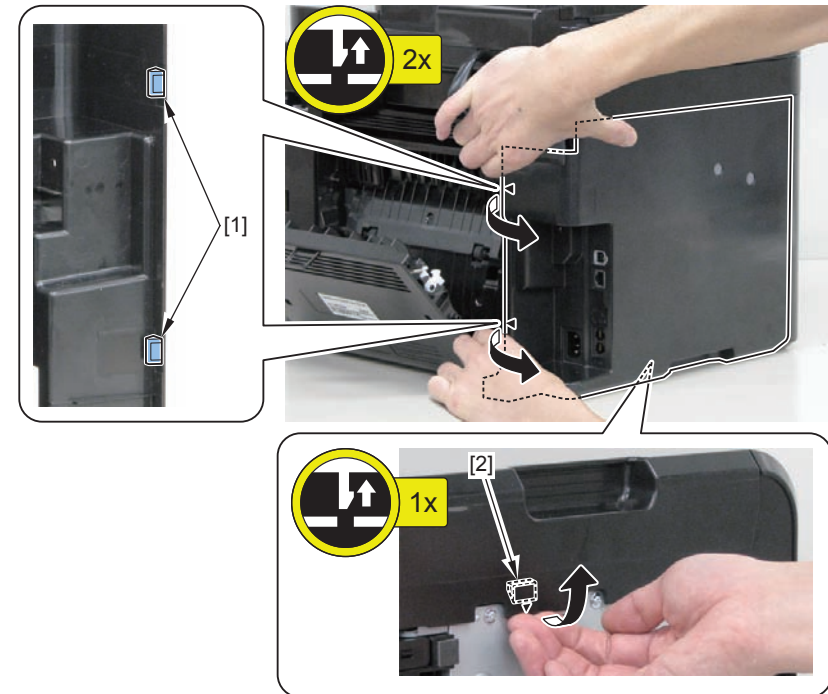

F-4-225

- 3-1) Open the DADF Unit + Reader Unit [1] (DADF Model).
 3-2) Open the SADF Unit + Reader Unit [1] (SADF Model).
 3-3) Open the Copyboard Cover + Reader Unit [1] (Copyboard Model).



F-4-226

- 4) Release the 2 claws [1] at the upper side and remove the Left Cover [3] while releasing the 3 hooks [2].

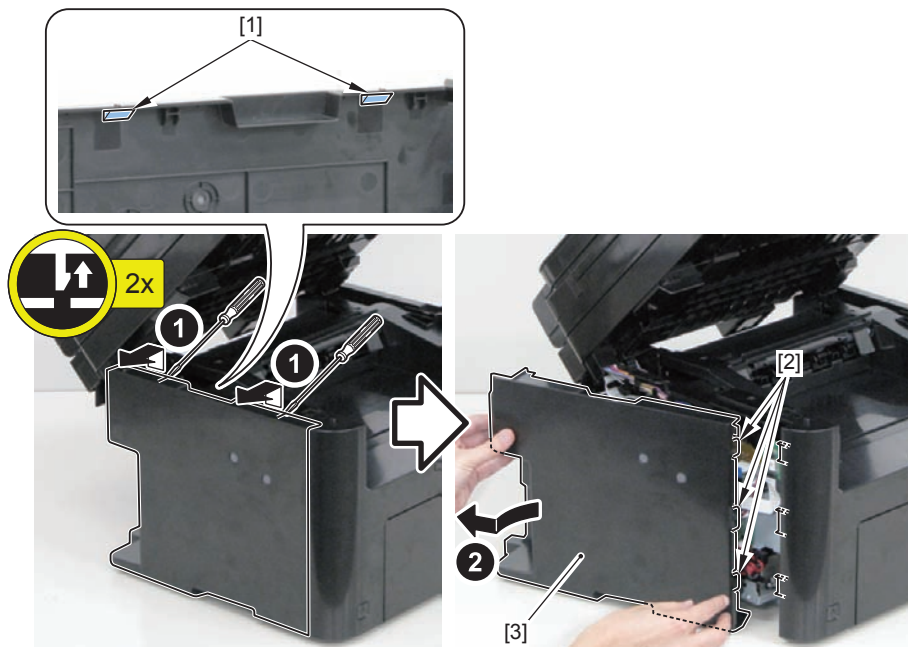

F-4-227

Removing the Right Cover (Duplex Model)



F-4-228

Procedure

NOTE:

The following shows the 5 claws [1] and 3 hooks [2] of the Right Cover.

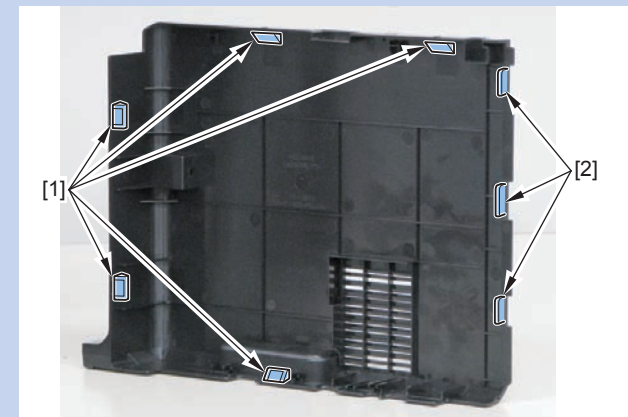

F-4-229

1) Open the Rear Cover [1], and remove the screw (black TP) [2].

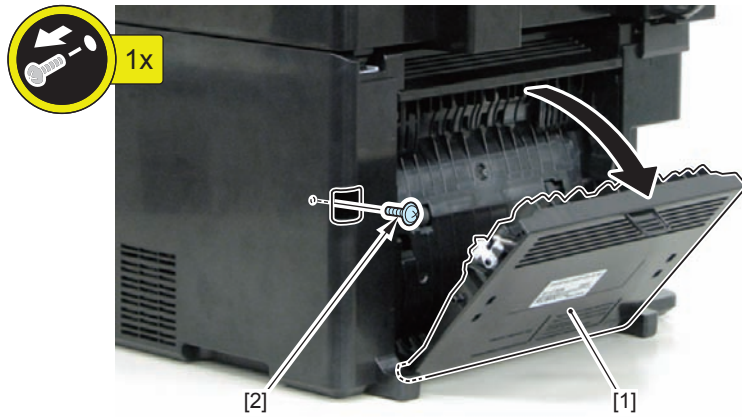

F-4-230

2) Release the 2 claws [1] at the rear side and the claw [2] at the lower side.

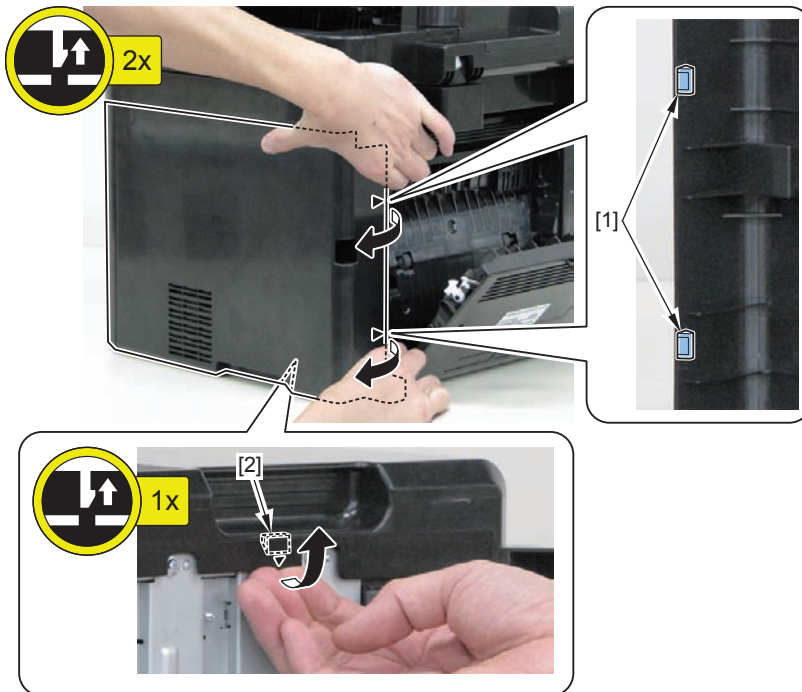

F-4-231

3-1) Open the DADF Unit + Reader Unit [1] (DADF Model).

3-2) Open the SADF Unit + Reader Unit [1] (SADF Model).

3-3) Open the Copyboard Cover + Reader Unit [1] (Copyboard Model).

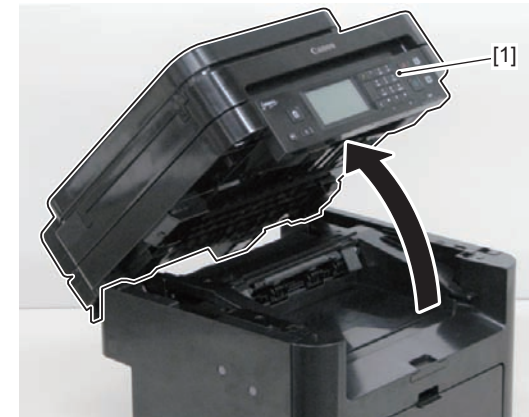

F-4-232

4) Release the 2 claws [1] at the upper side and remove the Left Cover [3] while releasing the 3 hooks [2].

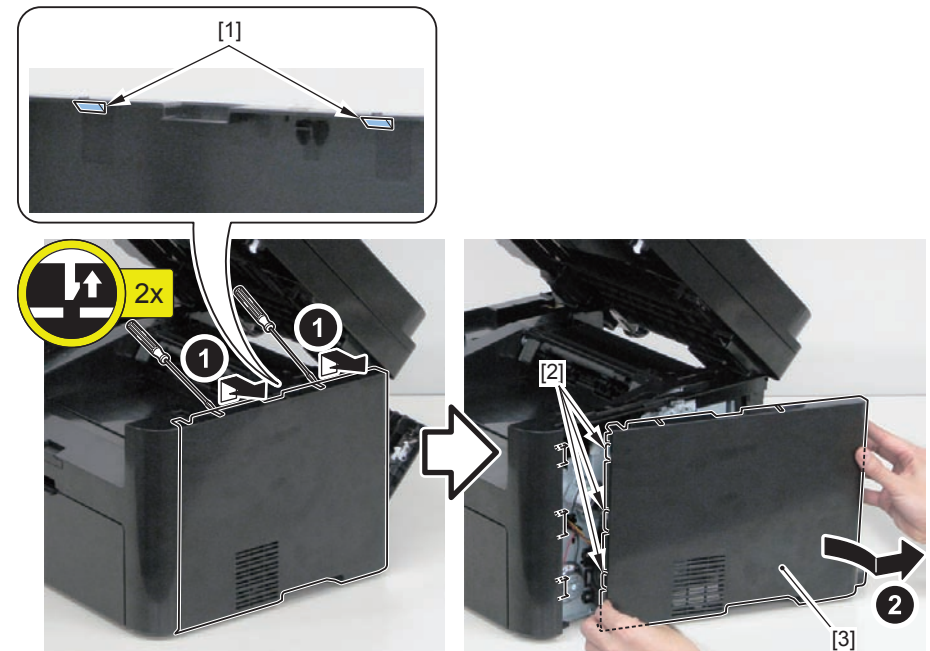

F-4-233

Removing the Front Cover Unit (Duplex Model)



F-4-234

Preparation

- 1) Remove the Left Cover (Duplex Model) (Refer to page 4-86).
- 2) Remove the Right Cover (Duplex Model) (Refer to page 4-87).

Procedure

- 1) Remove the Front Cover Unit [1].
 - 1 Connector [2]
 - 2 Bosses [3]
 - 2 Claws [4]

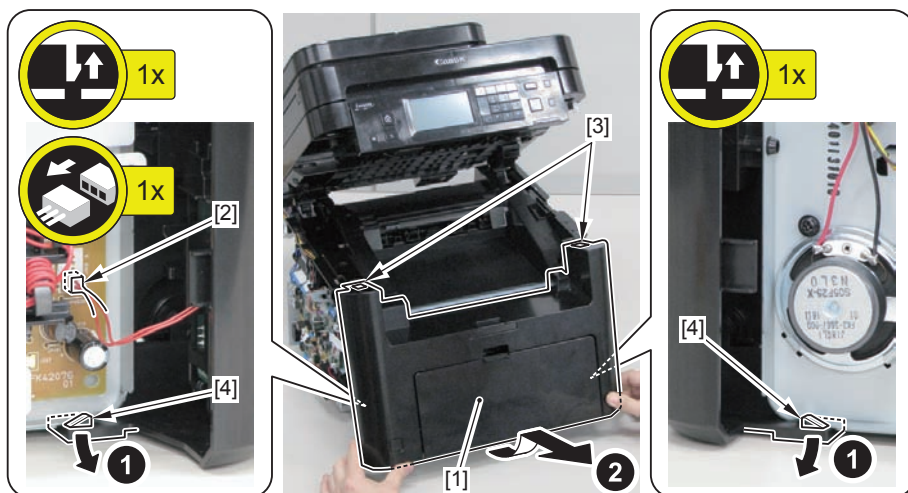

F-4-235

Removing the Upper Cover Unit (Duplex Model)



F-4-236

Preparation

- 1) Remove the Left Cover (Duplex Model) (Refer to page 4-86).
- 2-1) Remove the DADF Unit + Reader Unit (DADF Model) (Refer to page 4-27).
- 2-2) Remove the SADF Unit + Reader Unit (SADF Model) (Refer to page 4-51).
- 2-3) Remove the Copyboard Cover + Reader Unit (Copyboard Model) (Refer to page 4-76).
- 3) Remove the Right Cover (Duplex Model) (Refer to page 4-87).
- 4) Remove the Front Cover Unit (Duplex Model) (Refer to page 4-89).

Procedure

- 1) Open the Delivery Tray [1].
- 2) Remove the Cartridge Arm [2].
- 3) Remove the 2 Fixing Pressure Arms [3].

CAUTION:

Be careful not to lose the Cartridge Arm [2] and the 2 Fixing Pressure Arms [3].

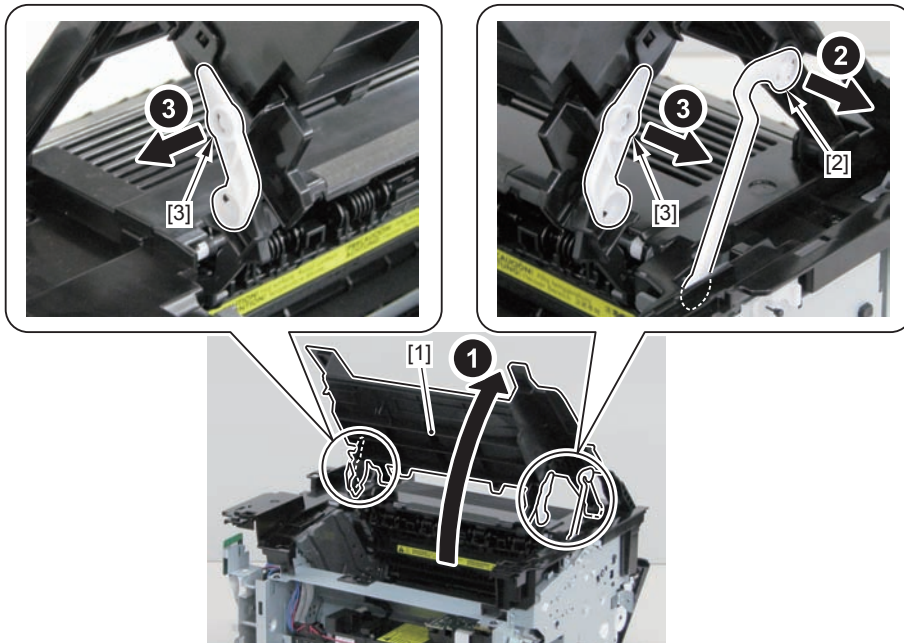

F-4-237

- 4) Remove the Delivery Tray [1].

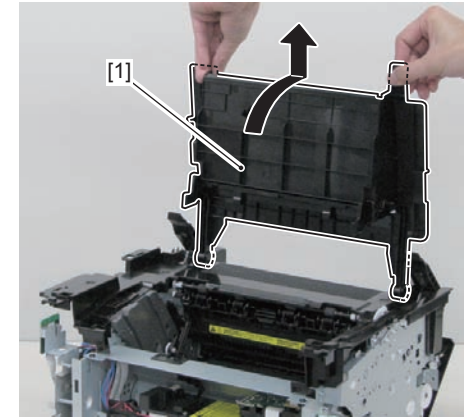

F-4-238

- 5) Remove the Upper Cover Unit [1].

- 4 Screws (black TP) [2]

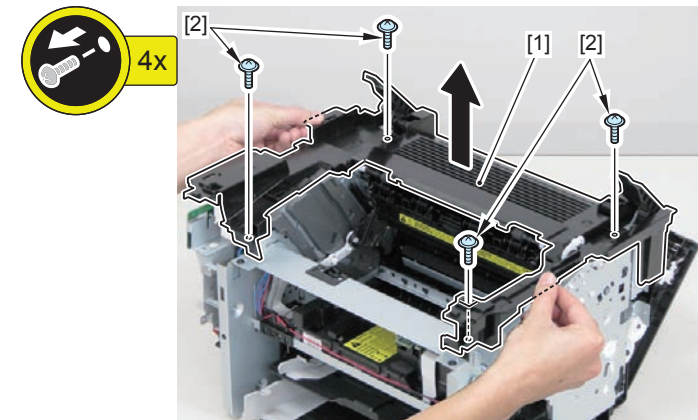

F-4-239

NOTE: How to assemble the Delivery Tray

- 1) Pass the Cartridge Arm [1] through the hole [A] of the Upper Cover Unit.
- 2) Install the Cartridge Arm [1] and the 2 Fixing Pressure Arms [2] to the Delivery Tray [3].

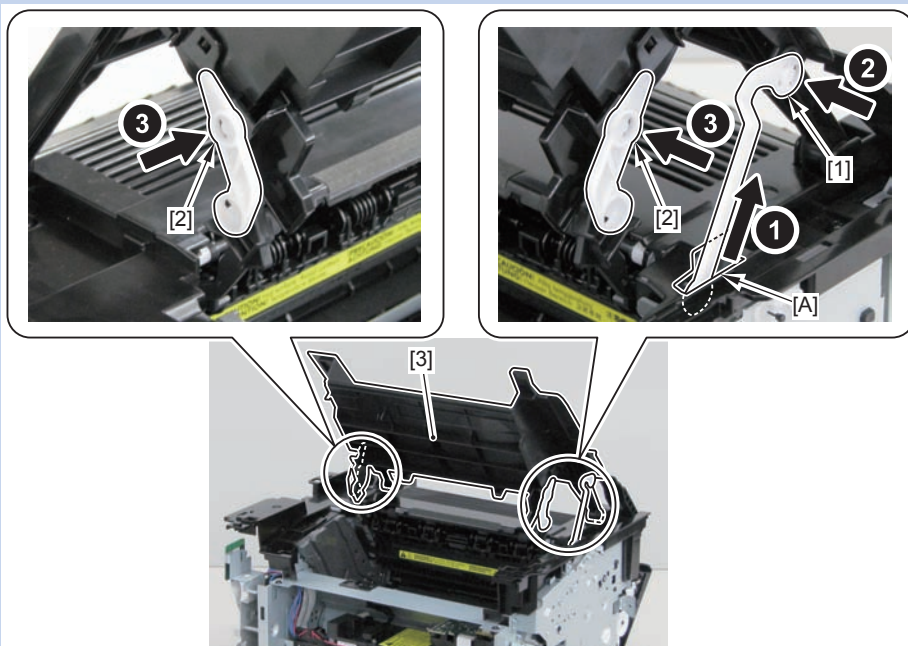

F-4-240

Removing the Duplex Feed Guide Unit. (Duplex Model)



F-4-241

Preparation

- 1) Remove the Left Cover (Duplex Model) (Refer to page 4-86).
- 2-1) Remove the DADF Unit + Reader Unit (DADF Model) (Refer to page 4-27).
- 2-2) Remove the SADF Unit + Reader Unit (SADF Model) (Refer to page 4-51).
- 2-3) Remove the Copyboard Cover + Reader Unit (Copyboard Model) (Refer to page 4-76).
- 3) Remove the Right Cover (Duplex Model) (Refer to page 4-87).
- 4) Remove the Front Cover Unit (Duplex Model) (Refer to page 4-89).
- 5) Remove the Upper Cover Unit (Duplex Model) (Refer to page 4-89).

Procedure

- 1) Remove the Duplex Guide [1].
 - 2 Claws [2]

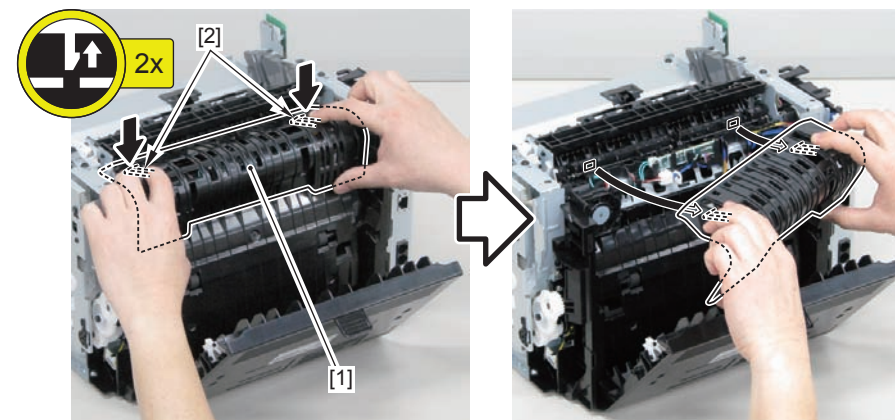

F-4-242

2) Remove the 2 screws (TP) [1] and the 2 screws (tapping) [2] using a stubby screwdriver.

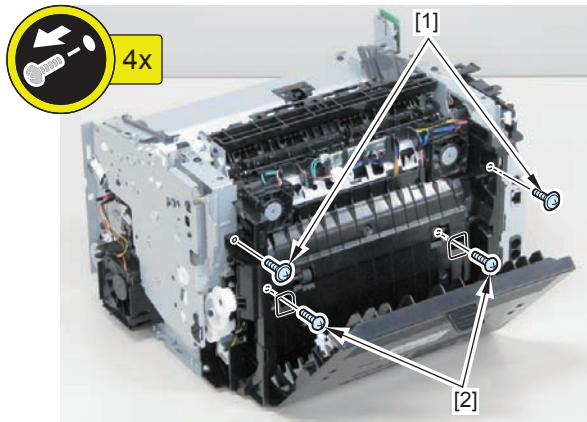

F-4-243

3) Close the Rear Cover [1].

4) Remove the Duplex Feed Guide Unit [2].

- 1 Claw [3]
- 2 Hooks [4]

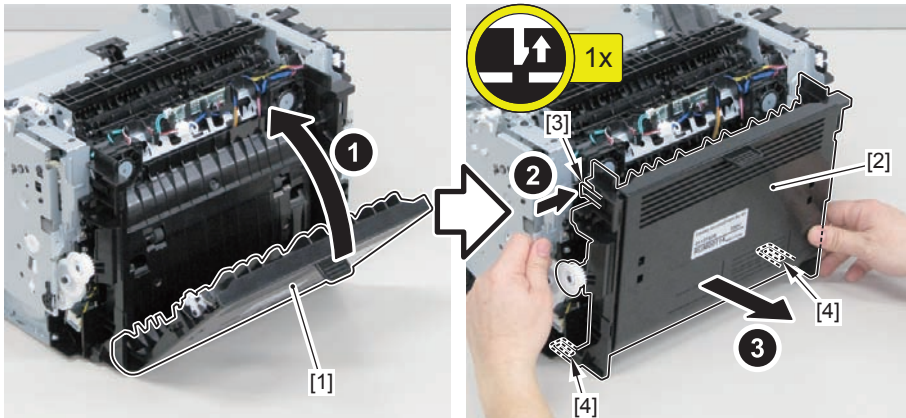

F-4-244

Controller System (Duplex Model)

Layout Drawing

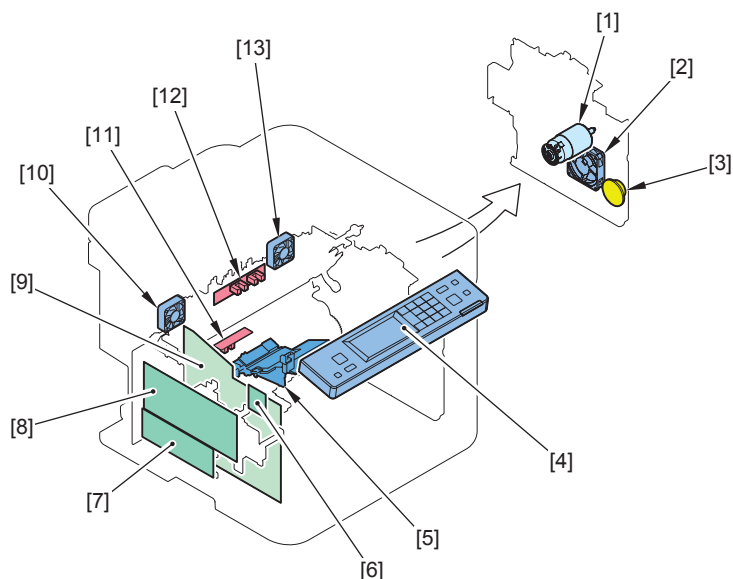

F-4-245

No.	Name	Reference	Remarks
[1]	Main Motor	(Refer to page 4-95)	
[2]	Main Fan	(Refer to page 4-97)	
[3]	Speaker	(Refer to page 4-116)	Fax Model
[4]	Control Panel Unit	(Refer to page 4-93)	
[5]	Toner Sensor and Multi Pickup Sensor Unit	(Refer to page 4-114)	Fax Model
[6]	Wireless LAN PCB	(Refer to page 4-108)	Wifi Model
[7]	FAX NCU PCB	(Refer to page 4-107)	Fax Model 120V/230V
[8]	Main Controller PCB	(Refer to page 4-105)	
[9]	Engine Controller PCB	(Refer to page 4-102)	
[10]	Edge Left Cooling Fan	(Refer to page 4-99)	
[11]	Paper Leading Edge Sensor PCB	(Refer to page 4-108)	
[12]	Fixing Delivery/Paper Width Sensor PCB	(Refer to page 4-111)	
[13]	Edge Right Cooling Fan	(Refer to page 4-101)	

T-4-40

Removing the Control Panel Unit (Duplex Model)



F-4-246

Procedure

- 1-1) Open the DADF Unit + Reader Unit [1] (DADF Model).
- 1-2) Open the SADF Unit + Reader Unit [1] (SADF Model).
- 1-3) Open the Copyboard Cover + Reader Unit [1] (Copyboard Model).
- 2) Lift the Control Panel Unit [2].

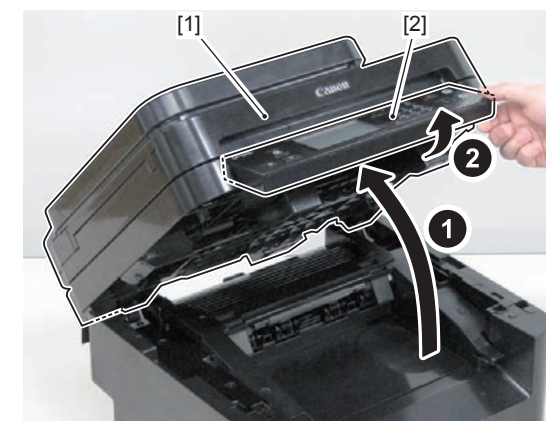

F-4-247

3) Remove the 4 Screws [1].

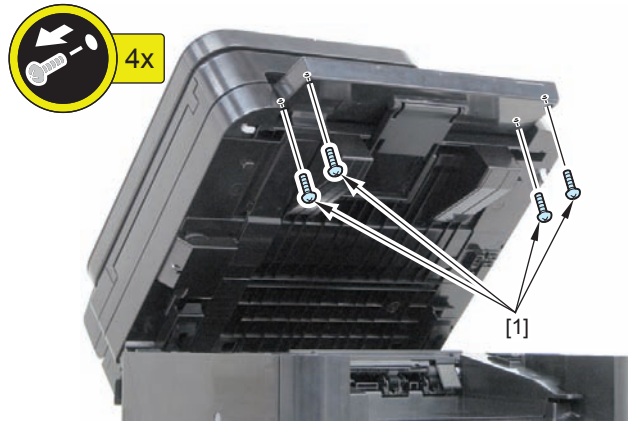

F-4-248

- 4-1) Close the Reader Unit [1], and open the DADF Unit [2] (DADF Model).
 4-2) Close the Reader Unit [1], and open the SADF Unit [2] (SADF Model).
 4-3) Close the Reader Unit [1], and open the Copyboard Unit [2] (Copyboard Model).

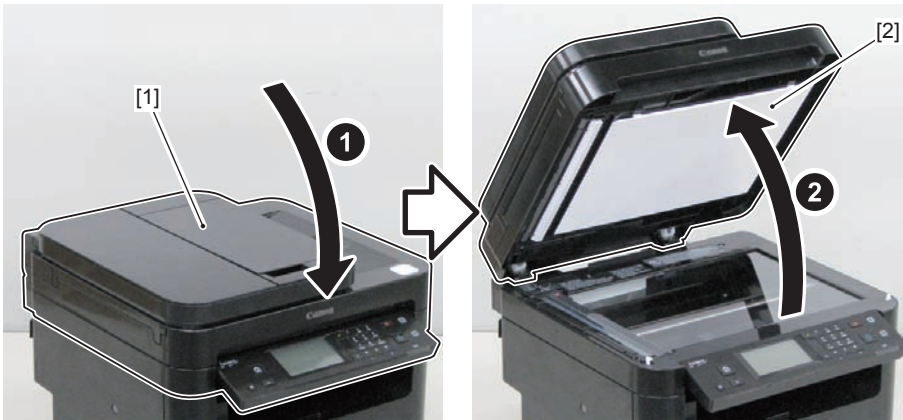

F-4-249

5) Remove the Control Panel Unit [1].

- 6 Claws [2]
- 1 Flat Cable [3]

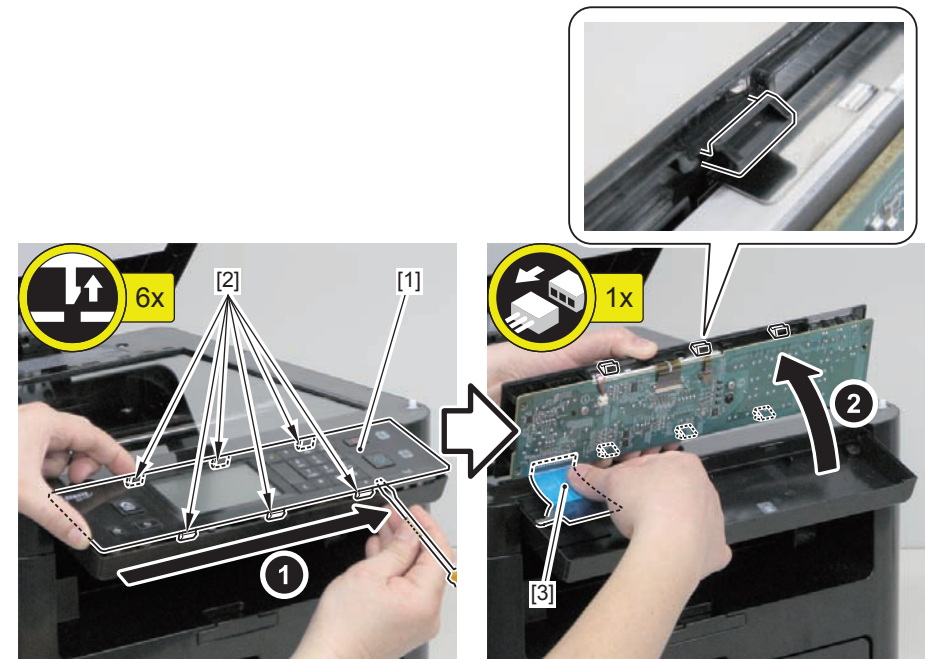

F-4-250

Removing the Main Motor (Duplex Model)



F-4-251

Preparation

- 1) Remove the Left Cover (Duplex Model) (Refer to page 4-86).
- 2-1) Remove the DADF Unit + Reader Unit (DADF Model) (Refer to page 4-27).
- 2-2) Remove the SADF Unit + Reader Unit (SADF Model) (Refer to page 4-51).
- 2-3) Remove the Copyboard Cover + Reader Unit (Copyboard Model) (Refer to page 4-76).
- 3) Remove the Right Cover (Duplex Model) (Refer to page 4-87).
- 4) Remove the Front Cover Unit (Duplex Model) (Refer to page 4-89).
- 5) Remove the Upper Cover Unit (Duplex Model) (Refer to page 4-89).

Procedure

- 1) Remove the Scanner Cover [1].
 - 2 Screws (black TP) [2]

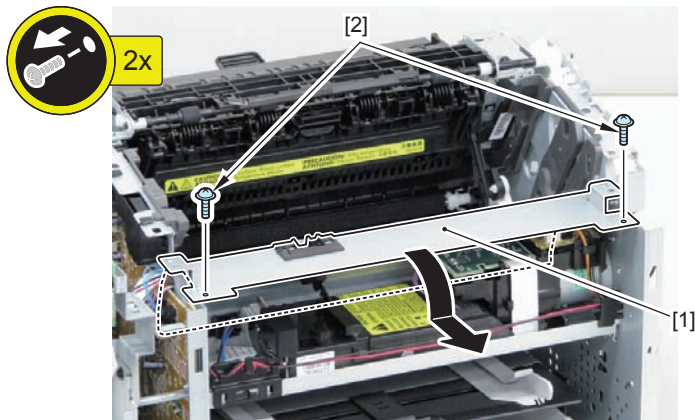

F-4-252

NOTE: How to assemble the Scanner Cover

- 1) Be sure to pass the Shutter Open/Close Lever [3] through the hole [A] of the Scanner Cover.

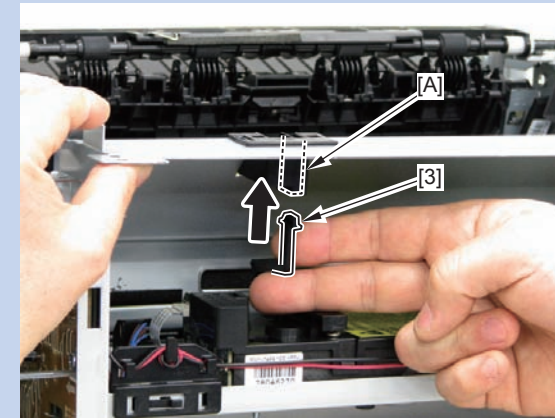

F-4-253

- 2) Be sure that the Shutter Open/Close Lever [3] can move vertically.

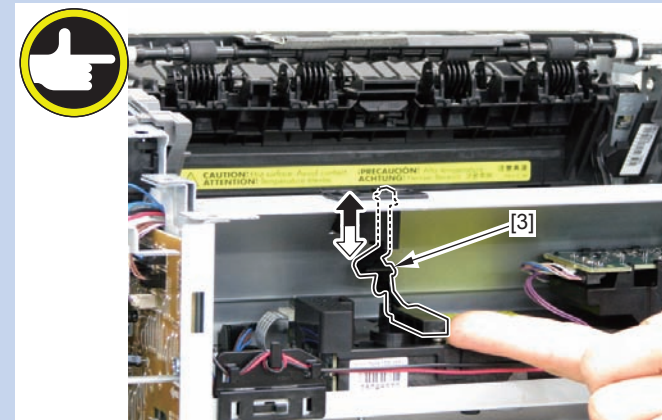

F-4-254

2) Remove the Motor Driver PCB [1].

- 3 Connectors [2]
- 2 Claws [3]
- 1 Hook [4]

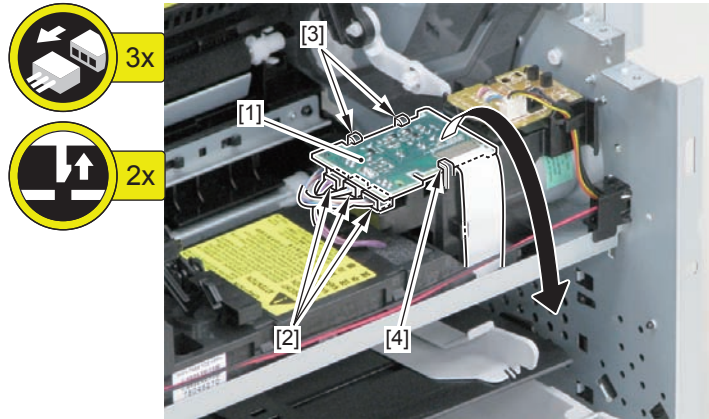

F-4-255

3) Free the harness [1] from the Harness Guide [A].

4) Remove the Duplex Relay PCB [2].

- 1 Claw [3]
- 1 Hook [4]

5) Free the harness [5] from the Harness Guide [B].

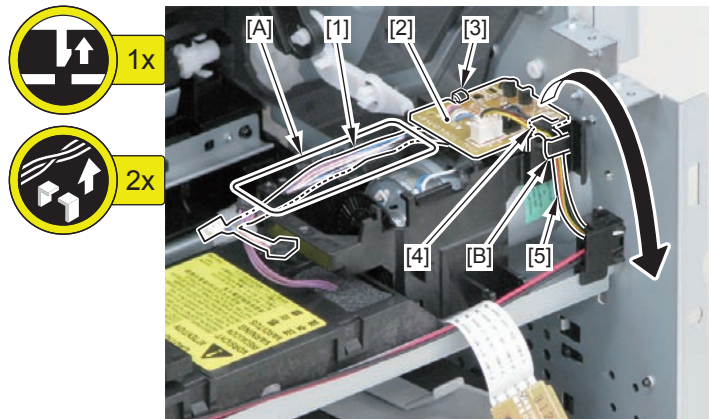

F-4-256

6) Free the Motor Harness [1] from the Harness Guide [A].

7) Remove the Motor Guide [2].

- 1 Screw [3]
- 1 Hook [4]

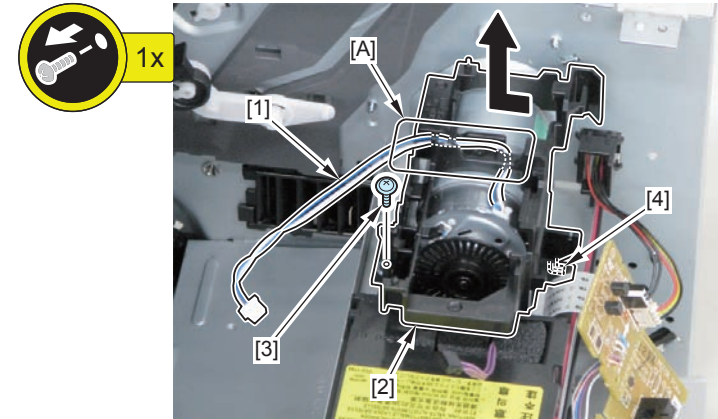

F-4-257

8) Remove the Tension Unit [1].

- 1 Screw [2]

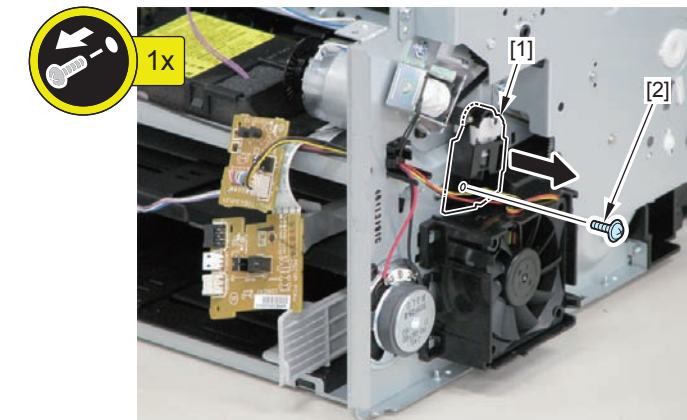

F-4-258

9) Remove the Main Motor [1].

- 2 Screws (with plain washer) [2]

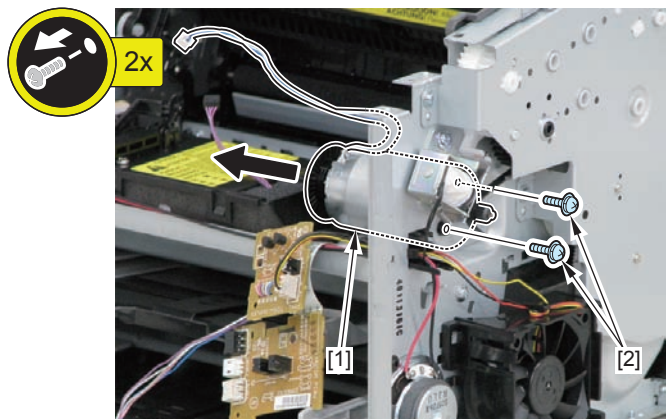

F-4-259

NOTE: How to assemble the Main Motor

Be sure to assemble it with the harness [1] routed upwards.

(Otherwise, the connector of the Speaker Harness cannot reach the Motor Driver PCB.)

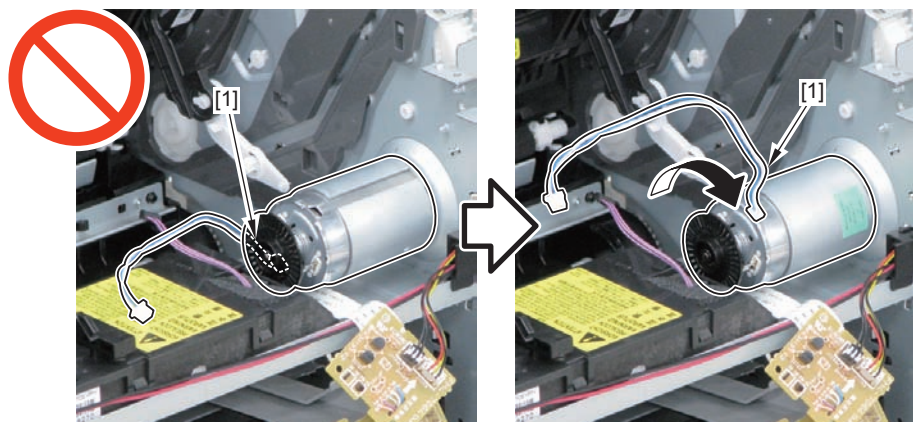

F-4-260

Removing the Main Fan (Duplex Model)

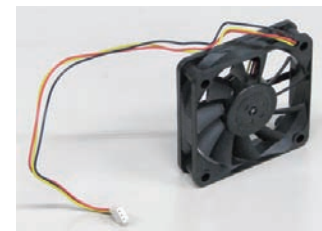

F-4-261

Preparation

- 1) Remove the Left Cover (Duplex Model) (Refer to page 4-86).
- 2-1) Remove the DADF Unit + Reader Unit (DADF Model) (Refer to page 4-27).
- 2-2) Remove the SADF Unit + Reader Unit (SADF Model) (Refer to page 4-51).
- 2-3) Remove the Copyboard Cover + Reader Unit (Copyboard Model) (Refer to page 4-76).
- 3) Remove the Right Cover (Duplex Model) (Refer to page 4-87).
- 4) Remove the Front Cover Unit (Duplex Model) (Refer to page 4-89).
- 5) Remove the Upper Cover Unit (Duplex Model) (Refer to page 4-89).

Procedure

1) Remove the Scanner Cover [1].

- 2 Screws (black TP) [2]

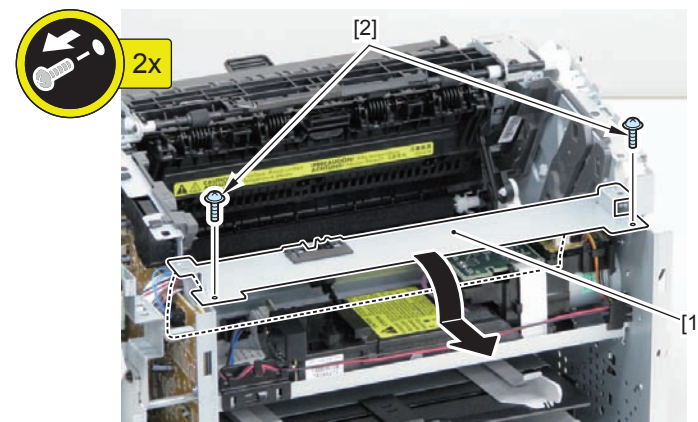

F-4-262

NOTE: How to assemble the Scanner Cover

- 1) Be sure to pass the Shutter Open/Close Lever [3] through the hole [A] of the Scanner Cover.

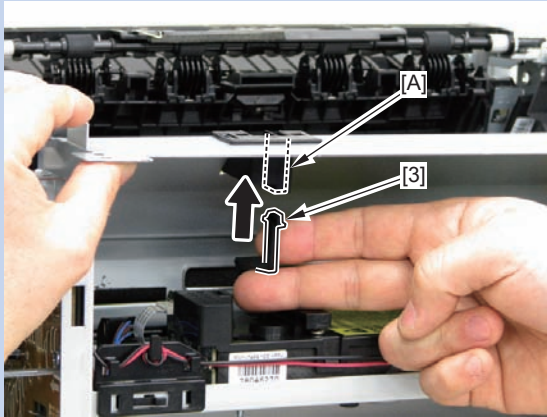

F-4-263

- 2) Be sure that the Shutter Open/Close Lever [3] can move vertically.

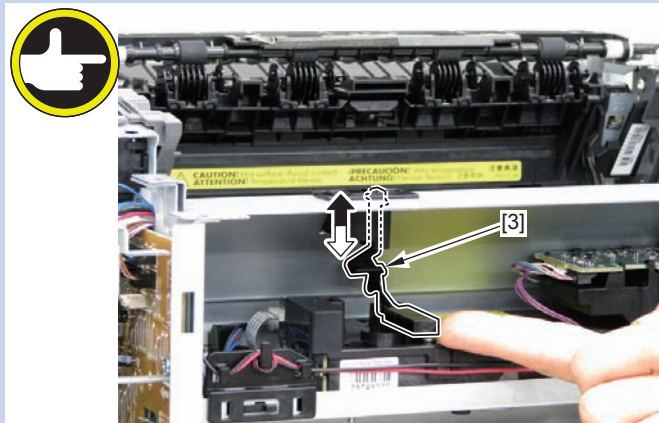

F-4-264

- 2) Free the Fan Harness [1] from the Harness Guide [A].

- 1 Connector [2]

- 3) Pass the Fan Harness [1] through the hole [B] of the Right Plate to the outside.

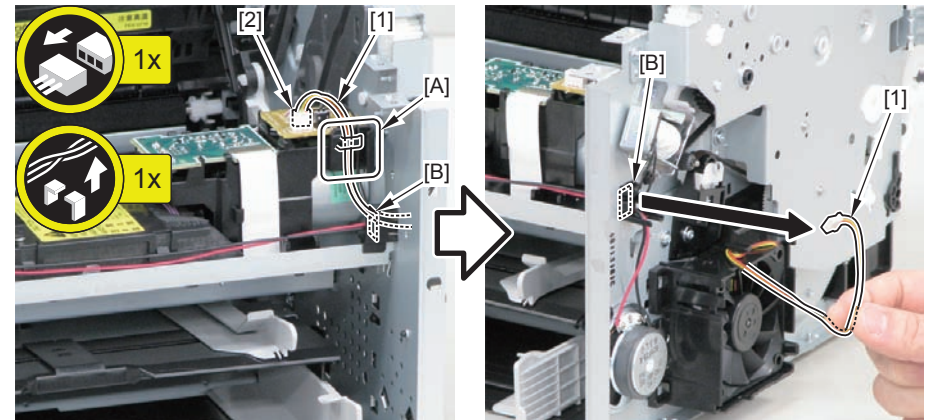

F-4-265

- 4) Free the harness [1] from the guide [A], and remove the Main Fan [2].

- 2 Claws [3]

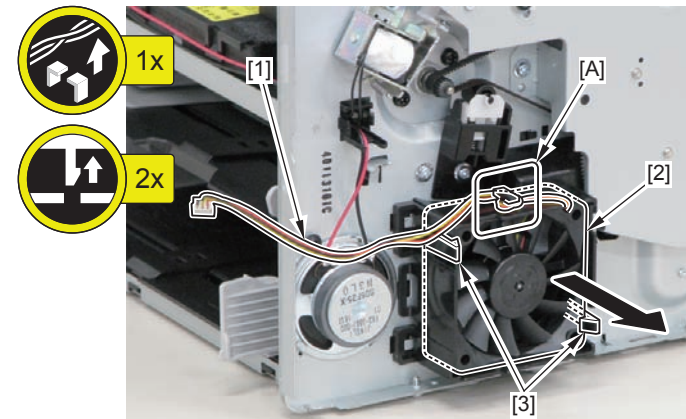

F-4-266

NOTE: How to assemble the Main Fan

Assemble it by aligning the arrow [1] of the Fan Guide with the arrow [2] of the fan and installing the harness [3] to the upper right side.

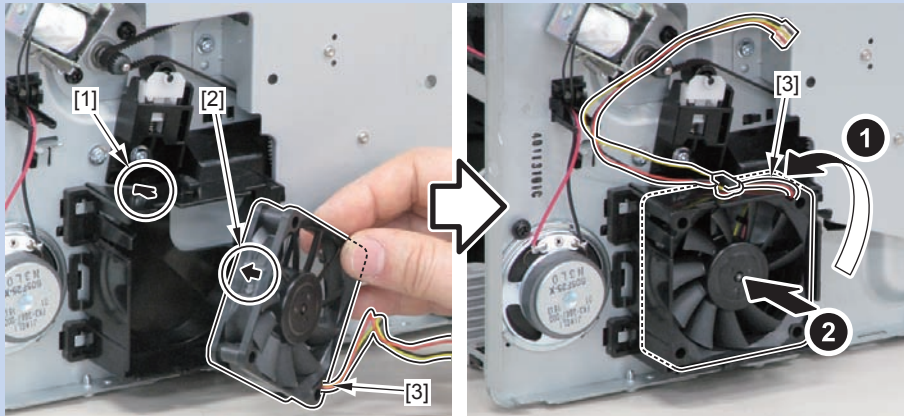

F-4-267

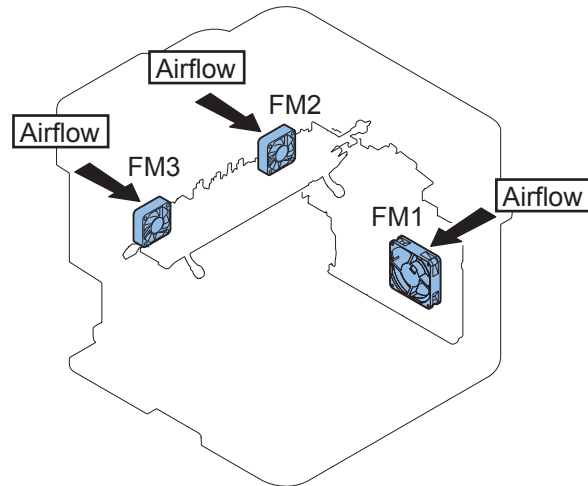

F-4-268

Removing the Edge Left Cooling Fan (Duplex Model)

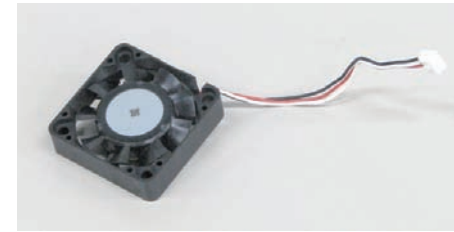

F-4-269

Preparation

- 1) Remove the Left Cover (Duplex Model) (Refer to page 4-86).
- 2-1) Remove the DADF Unit + Reader Unit (DADF Model) (Refer to page 4-27).
- 2-2) Remove the SADF Unit + Reader Unit (SADF Model) (Refer to page 4-51).
- 2-3) Remove the Copyboard Cover + Reader Unit (Copyboard Model) (Refer to page 4-76).
- 3) Remove the Right Cover (Duplex Model) (Refer to page 4-87).
- 4) Remove the Front Cover Unit (Duplex Model) (Refer to page 4-89).
- 5) Remove the Upper Cover Unit (Duplex Model) (Refer to page 4-89).
- 6) Remove the Duplex Feed Guide Unit (Duplex Model) (Refer to page 4-91).

Procedure

- 1) Remove the Front Fixing Reinforcing Plate [1].
 - 2 Screws (black TP) [2]

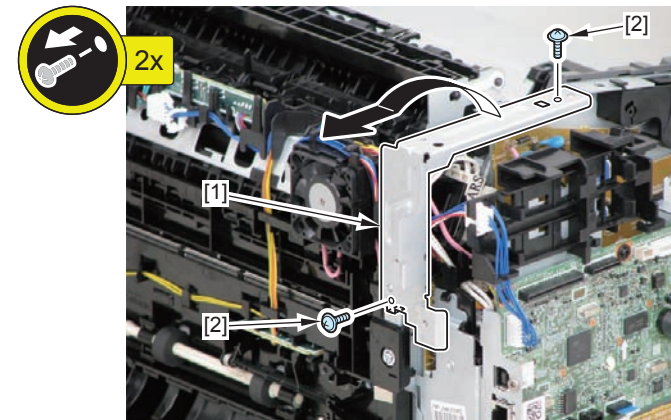

F-4-270

2) Remove the Edge Left Cooling Fan [1].

- 1 Left Fan Earth Spring [2]
- 1 Connector [3]
- 1 Harness Guide [A]
- 2 Claws [4]

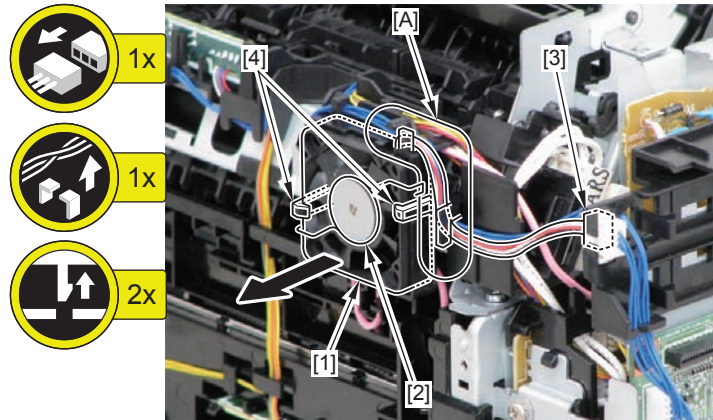

F-4-271

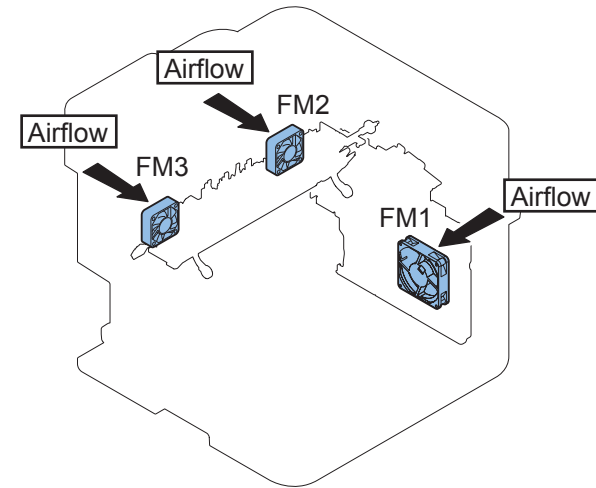

F-4-273

NOTE: How to assemble the Edge Left Cooling Fan

Assemble it by aligning the arrow [1] of the fan with the arrow [2] of the Fan Holder.

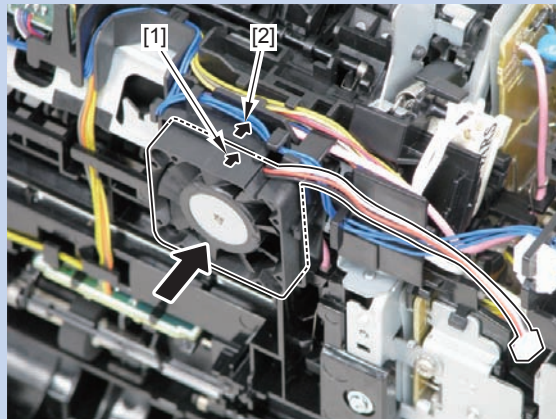

F-4-272

Removing the Edge Right Cooling Fan (Duplex Model)

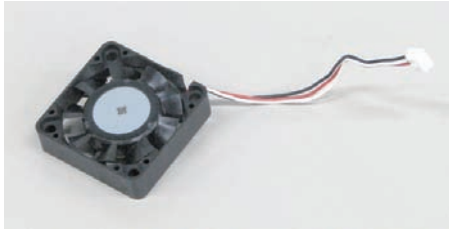

F-4-274

Preparation

- 1) Remove the Left Cover (Duplex Model) (Refer to page 4-86).
- 2-1) Remove the DADF Unit + Reader Unit (DADF Model) (Refer to page 4-27).
- 2-2) Remove the SADF Unit + Reader Unit (SADF Model) (Refer to page 4-51).
- 2-3) Remove the Copyboard Cover + Reader Unit (Copyboard Model) (Refer to page 4-76).
- 3) Remove the Right Cover (Duplex Model) (Refer to page 4-87).
- 4) Remove the Front Cover Unit (Duplex Model) (Refer to page 4-89).
- 5) Remove the Upper Cover Unit (Duplex Model) (Refer to page 4-89).
- 6) Remove the Duplex Feed Guide Unit (Duplex Model) (Refer to page 4-91).

Procedure

- 1) Remove the Edge Right Cooling Fan [1].

- 1 Right Fan Earth Spring [2]
- 1 Connector [3]
- 1 Harness Guide [A]
- 2 Claws [4]

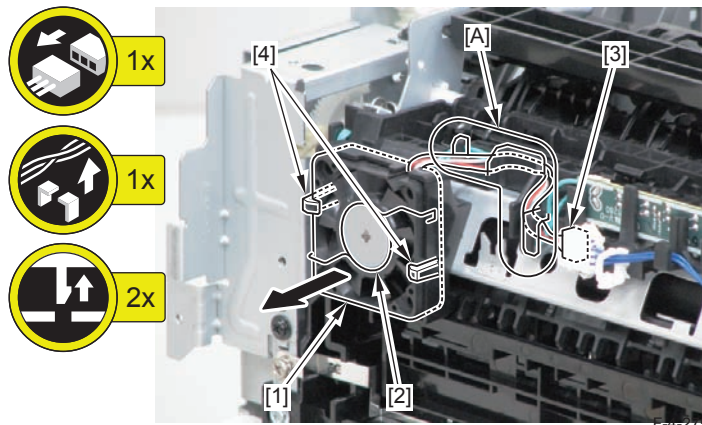

F-4-275

NOTE: How to assemble the Edge Right Cooling Fan

Assemble it by aligning the arrow [1] of the fan with the arrow [2] of the Fan Holder.

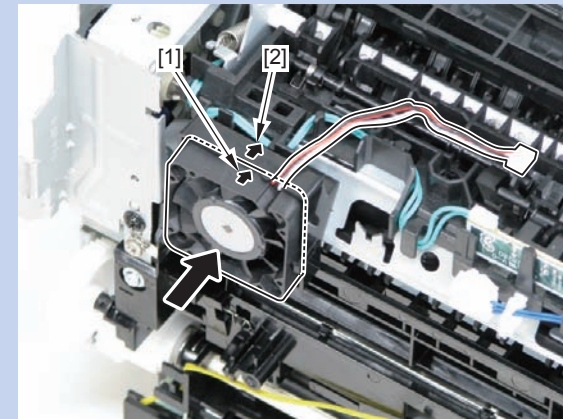

F-4-276

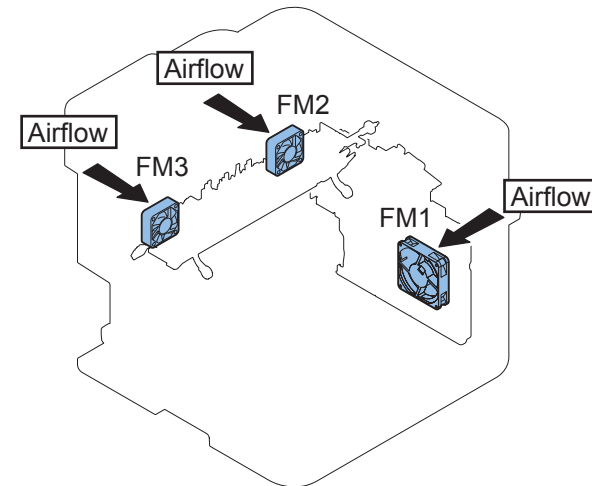

F-4-277

Removing the Engine Controller PCB (Duplex Model)

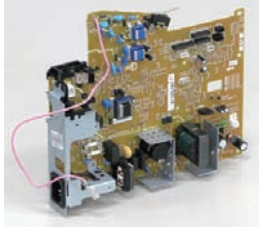

F-4-278

Preparation

- 1) Remove the Left Cover (Duplex Model) (Refer to page 4-86).
- 2-1) Remove the DADF Unit + Reader Unit (DADF Model) (Refer to page 4-27).
- 2-2) Remove the SADF Unit + Reader Unit (SADF Model) (Refer to page 4-51).
- 2-3) Remove the Copyboard Cover + Reader Unit (Copyboard Model) (Refer to page 4-76).
- 3) Remove the Right Cover (Duplex Model) (Refer to page 4-87).
- 4) Remove the Front Cover Unit (Duplex Model) (Refer to page 4-89).
- 5) Remove the Upper Cover Unit (Duplex Model) (Refer to page 4-89).
- 6) Remove the Duplex Feed Guide Unit (Duplex Model) (Refer to page 4-91).
- 7) Remove the Main Controller PCB (Duplex Model) (Refer to page 4-95).
- 8) Remove the FAX NCU PCB (FAX Model 120/230V) (Duplex Model) (Refer to page 4-107).
- 9) Remove the Edge Left Cooling Fan (Duplex Model) (Refer to page 4-99).

Procedure

- 1) Remove the Wireless LAN Unit [1] (Wifi Model).
 - 1 Screw (black TP) [2]
 - 2 Hooks [3]

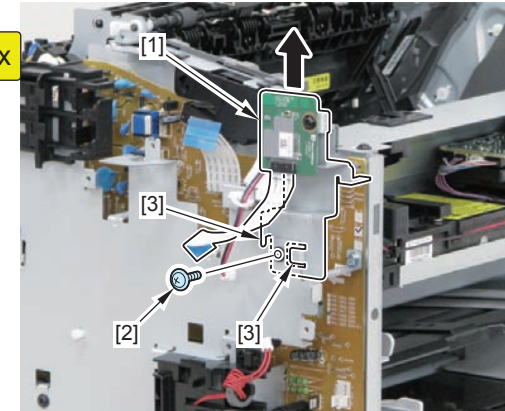

F-4-279

- 2) Remove the Main Controller PCB Installation Plate [1].
 - 1 Relay Connector [2]
 - Harness Guide [A]
 - 1 Wire Saddle [3]
 - 4 Screws (with washer) [4]
 - 2 Screws (black TP) [5]

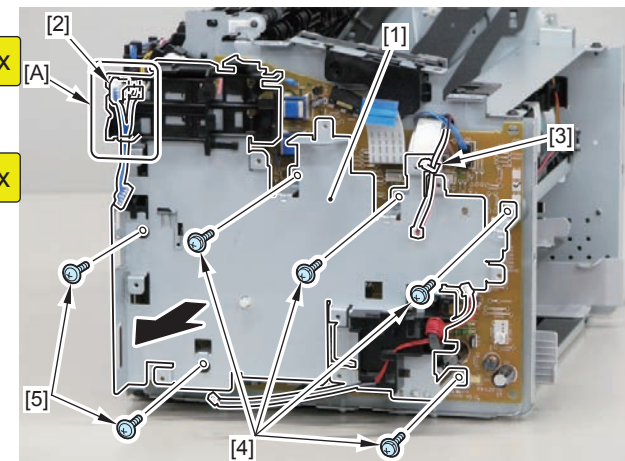

F-4-280

- 3) Free the harness [1] from the Harness Guide [A].
 - 4) Remove the Edge Left Cooling Fan Holder [2].
- 1 Screw [3]

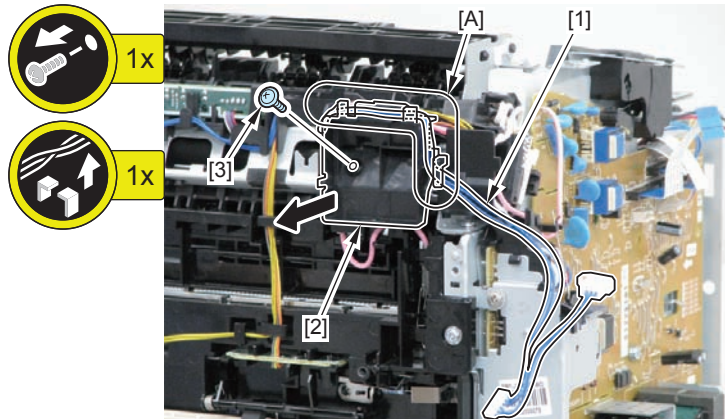

F-4-281

- 5) Free the harness [1] from the Harness Guide [A].
- 1 Terminal [2]

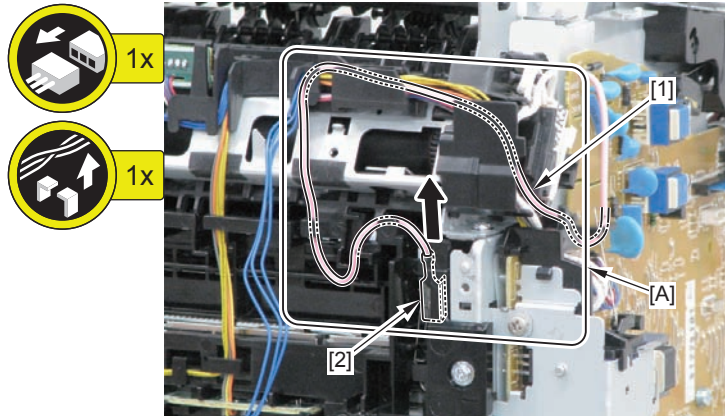

F-4-282

CAUTION:

Be sure that the terminal [2] is in contact with the Contact Spring [3].

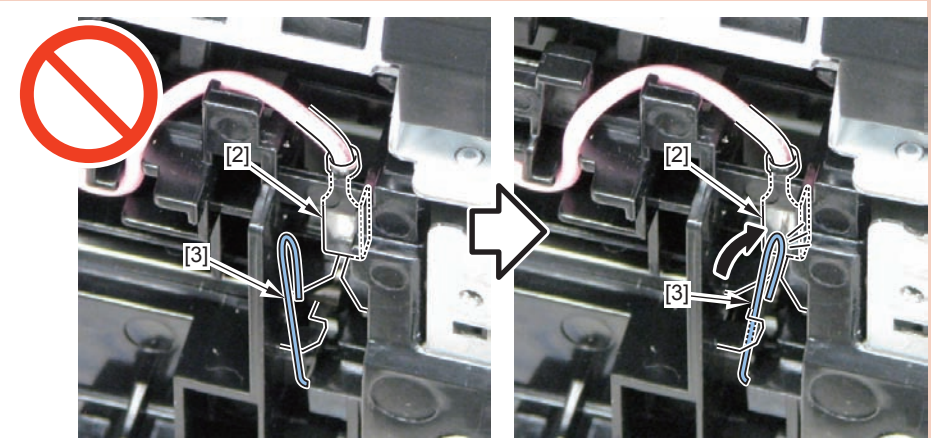

F-4-283

- 6) Remove the Harness Retaining Spring [1] from the 2 hooks [2].

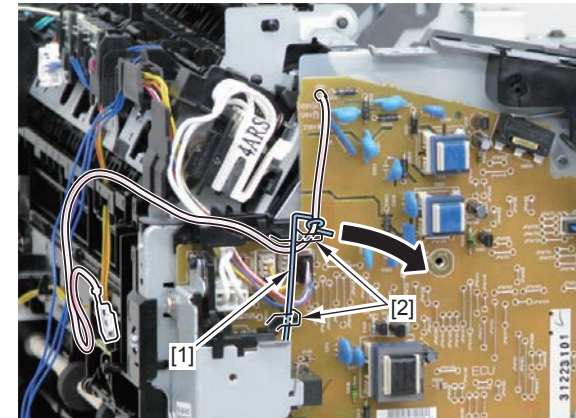

F-4-284

7) Remove the 3 Flat Cables [2], the 6 connectors [3], and the connector [4] (Fax Model) installed on the Engine Controller PCB [1].

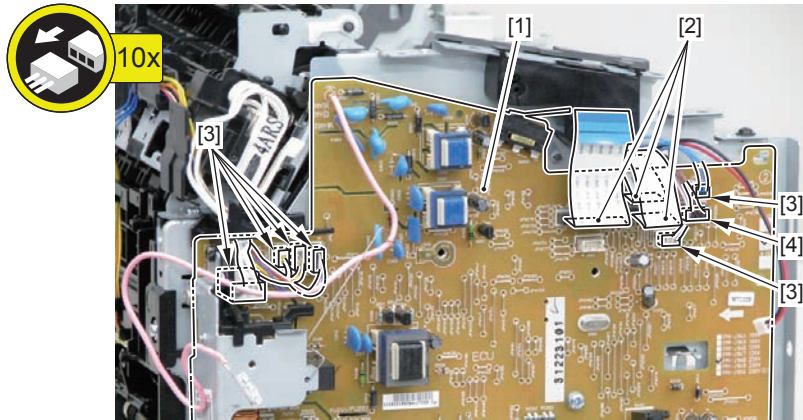

F-4-285

8) Free the harness [1] from the Harness Guide [A].

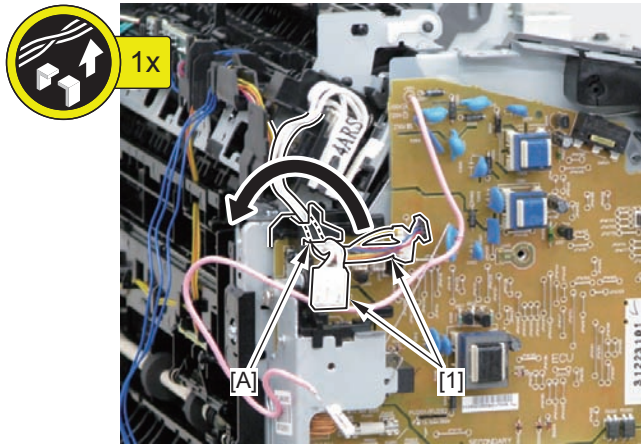

F-4-286

9) Remove the Engine Controller PCB [1].

- 2 Screws (with plain washer) [2]
- 1 Screw (with toothed lock washer) [3]
- 1 Screw (black TP) [4]
- 2 Hooks [5]

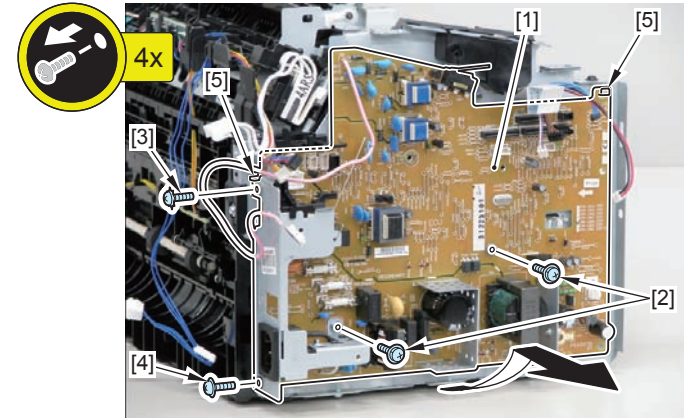

F-4-287

NOTE: How to assemble the Engine Controller PCB

- Put the Switchboard [2] in the lower part of the Switch Arm [1], and hook the Engine Controller PCB on the hook [3].

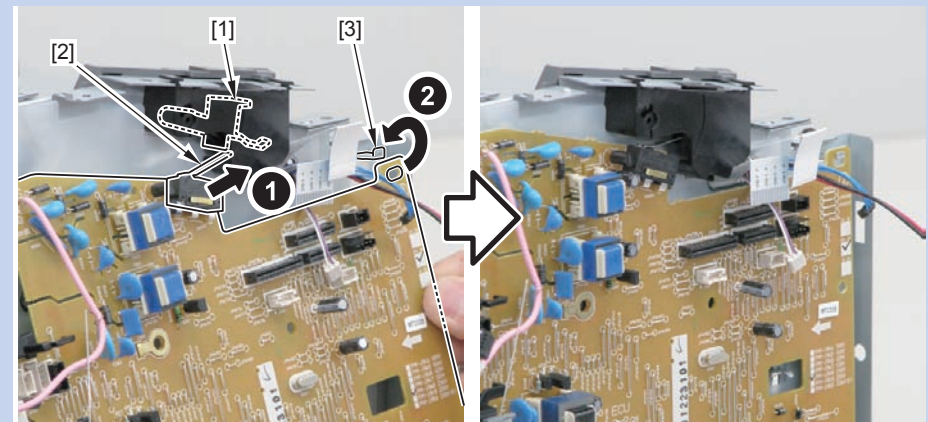

F-4-288

NOTE: How to assemble the Engine Controller PCB

- Be sure that the Switch Arm [1] can move vertically.

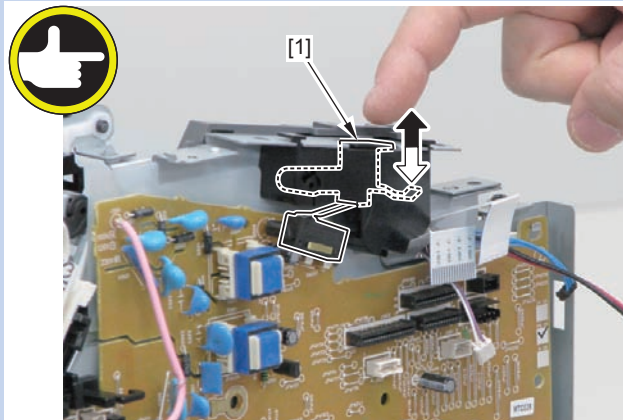

F-4-289

CAUTION:

Be careful not to install the Flat Cable [1] in the wrong direction.

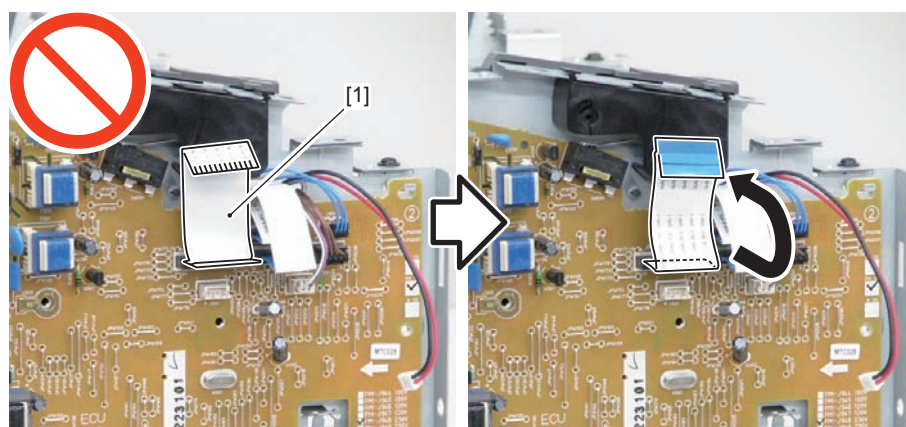

F-4-290

Removing the Main Controller PCB (Duplex Model)



F-4-291

Before Replacing

- 1) Before starting the replacement, output a status print.
After replacing the Main Controller, the serial number of the host machine needs to be written to the Main Controller.
- 2) Ask the user to perform the following operations if possible.
 - Ask the user to print the user data list.
[Menu] > [Output Report] > [Output Rprt.] > [User Data List]
 - Ask the user to save the address book from remote UI.
 1. Start remote UI and log in in administrator mode.
 2. Click [Settings/Registration] > [Import/Export] > [Export] > [Start Exporting].
 3. Follow the instructions on the screen to specify the location to save the address book.

Preparation

- 1) Remove the Left Cover (Duplex Model) (Refer to page 4-86).

Procedure

1) Disconnect all the Flat Cables [1] and connectors [2] installed on the Main Controller PCB.

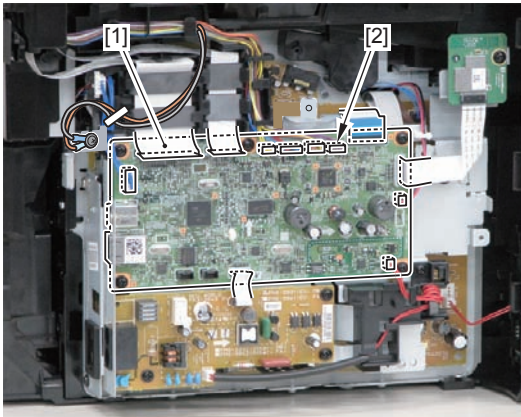

F-4-292

2) Remove the Main Controller PCB [1].

- 1 Screw [2]
- 5 Screws (black TP) [3]

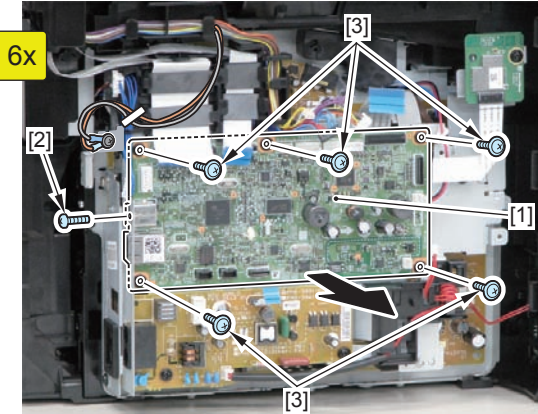

F-4-293

NOTE:

The layout of the connectors on the Main Controller PCB is shown below.

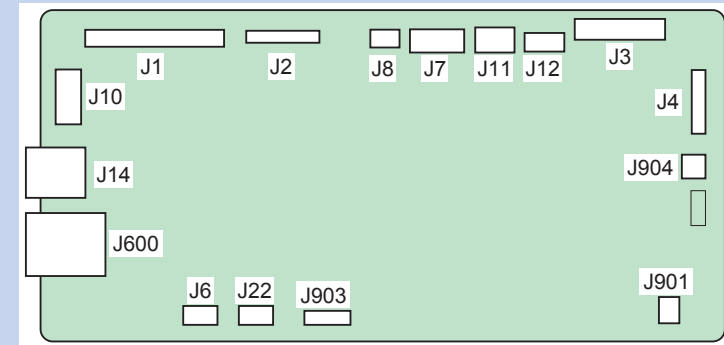

F-4-294

J No.	J No.	Symbol	Name	Remarks
J1	J401	UNIT14	Control Panel PCB	
J2	J1601	CIS	CIS Sensor	
J3	J902	UNIT2	Engine Controller PCB	
J4	J1	UNIT13	Wireless LAN PCB	WIFI Model
J6	-	-	-	
J7	J1402	PS2	Original Sensor	DADF Model
J7	J1403	PS3	Original Edge Sensor	DADF Model
J7	J1406	PS4	Original Sensor	SADF Model
J7	J1407	PS5	Original Edge Sensor	SADF Model
J8	-	SL3	DADF Solenoid Unit	DADF Model
J10	J102	FM2	Edge Right Cooling Fan	
J10	J103	FM3	Edge Left Cooling Fan	
J11	-	M3	Flatbed Motor Unit	
J12	J1401	M4	DADF Motor Unit	DADF Model
J12	J1401	M5	SADF Motor Unit	SADF Model
J14	-	-	USB	
J22	-	-	-	
J600	-	-	LAN	
J901	J1204	UNIT16	FAX NCU PCB	FAX Model
J903	J1201	UNIT16	FAX NCU PCB	FAX Model
J904	-	SP1	Speaker	FAX Model

T-4-41

After Replacing

- 1) After replacing the PCB, enter the serial number in "Location" of System Management Settings from remote UI or local UI, and confirm the serial number.
- 2) Check that OK is displayed in COPIER > OPTION > SERIAL > SN-MAIN.
 - For the detailed procedure, refer to the chapter on service mode.
- 3) COPIER > OPTION > BODY > LOCALE
To set country group.
 - 1: Japan
 - 2: North America
 - 3: Korea
 - 4: China
 - 5: Taiwan
 - 6: Europe
 - 7: Asia
 - 8: Oceania
 Setting range: 1 - 8 (Service part default value: 2)
- 4) Execute the following service mode to enable this setting.
COPIER > FUNCTION > CLEAR > ALL
- 5) If the user has printed the user data list and saved the address book before the replacement, ask the user to return the settings back to the original values.
 - Ask the user to load the address book from remote UI.
 1. Start remote UI and log in in administrator mode.
 2. [Settings/Registration] > [Import/Export] > [Import]
 3. Select the address book file to be imported, and click [Start Importing].
 4. Click [OK].

Removing the FAX NCU PCB (Fax Model 120V/230V) (Duplex Model)

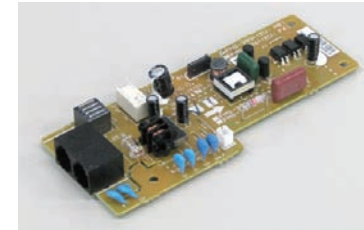

F-4-295

Preparation

- 1) Remove the Left Cover (Duplex Model) (Refer to page 4-86).

Procedure

- 1) Remove the FAX NCU PCB [1].
 - 1 Flat Cable [2]
 - 1 Connector [3]
 - 3 Screws [4]

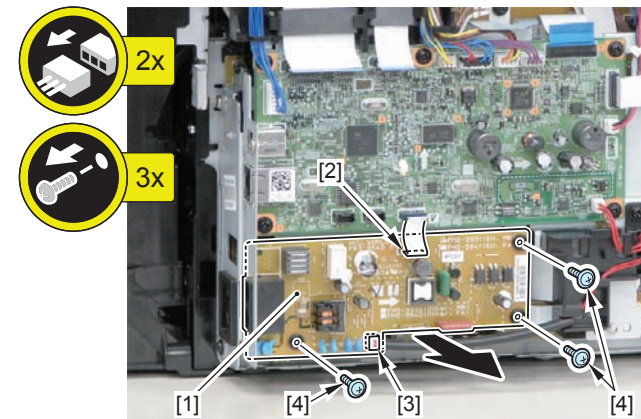

F-4-296

Removing the Wireless LAN PCB (Wifi Model + Duplex Model)



F-4-297

Preparation

1) Remove the Left Cover (Duplex Model) (Refer to page 4-86).

Procedure

1) Remove the Wireless LAN PCB [1].

- 1 Flat Cable [2]
- 1 Screw (black TP) [3]

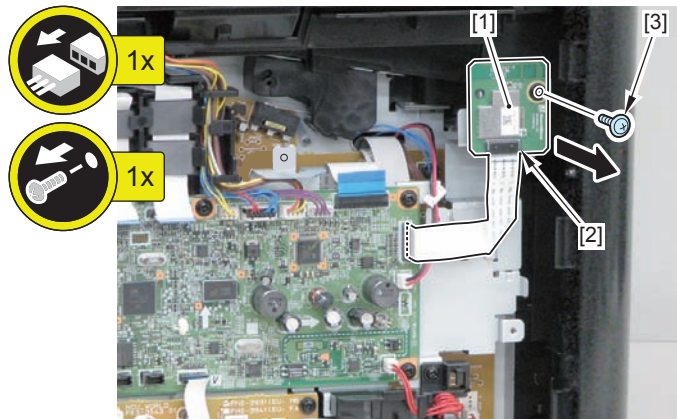

F-4-298

Removing the Paper Leading Edge Sensor PCB (Duplex Model)

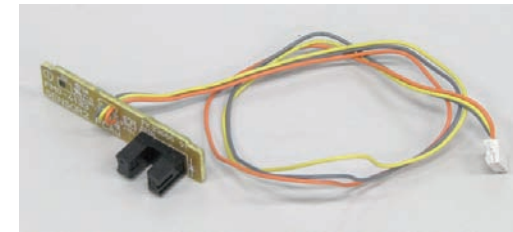

F-4-299

Preparation

1) Remove the Left Cover (Duplex Model) (Refer to page 4-86).

2-1) Remove the DADF Unit + Reader Unit (DADF Model) (Refer to page 4-27).

2-2) Remove the SADF Unit + Reader Unit (SADF Model) (Refer to page 4-51).

2-3) Remove the Copyboard Cover + Reader Unit (Copyboard Model) (Refer to page 4-76).

3) Remove the Right Cover (Duplex Model) (Refer to page 4-87).

4) Remove the Front Cover Unit (Duplex Model) (Refer to page 4-89).

5) Remove the Upper Cover Unit (Duplex Model) (Refer to page 4-89).

6) Remove the Duplex Feed Guide Unit (Duplex Model) (Refer to page 4-91).

7) Remove the Main Controller PCB (Duplex Model) (Refer to page 4-95).

8) Remove the FAX NCU PCB (FAX Model 120/230V) (Duplex Model) (Refer to page 4-107).

9) Remove the Edge Left Cooling Fan (Duplex Model) (Refer to page 4-99).

Procedure

1) Remove the Wireless LAN Unit [1] (Wifi Model).

- 1 Screw (black TP) [2]
- 2 Hooks [3]

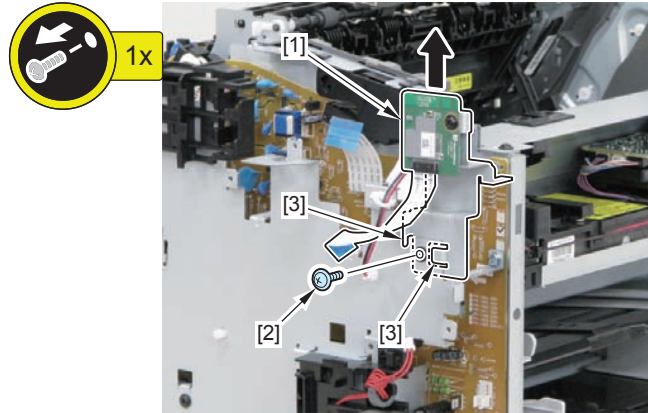

F-4-300

2) Remove the Main Controller PCB Installation Plate [1].

- 1 Relay Connector [2]
- Harness Guide [A]
- 1 Wire Saddle [3]
- 4 Screws (with washer) [4]
- 2 Screws (black TP) [5]

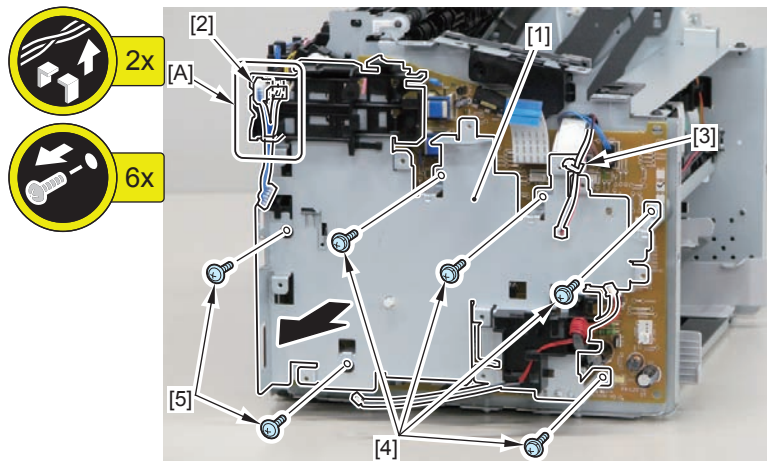

F-4-301

NOTE:

The Front Fixing Reinforcing Plate [1] should be removed before removing the Edge Left Cooling Fan Holder.

- 2 Screws (black TP) [2]

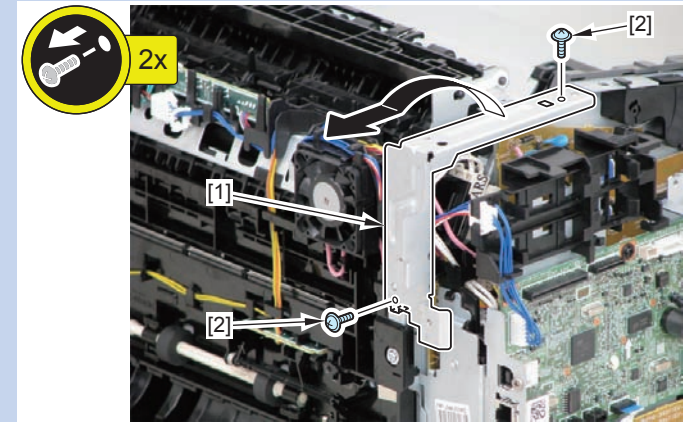

F-4-302

3) Free the harness [1] from the Harness Guide [A].

4) Remove the Edge Left Cooling Fan Holder [2].

- 1 Screw [3]

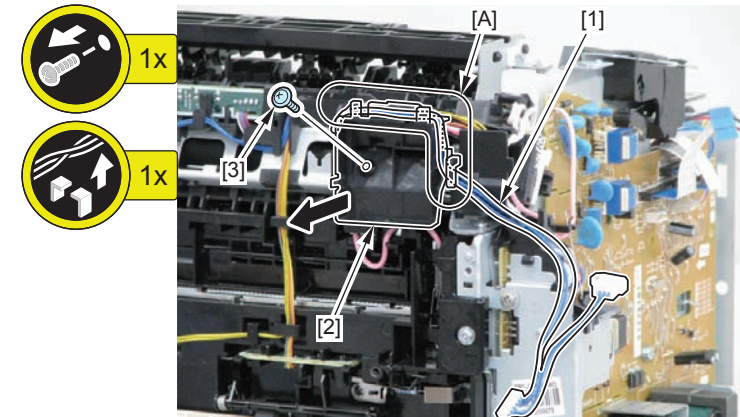

F-4-303

5) Free the harness [1] from the Harness Guide [A].

- 1 Terminal [2]

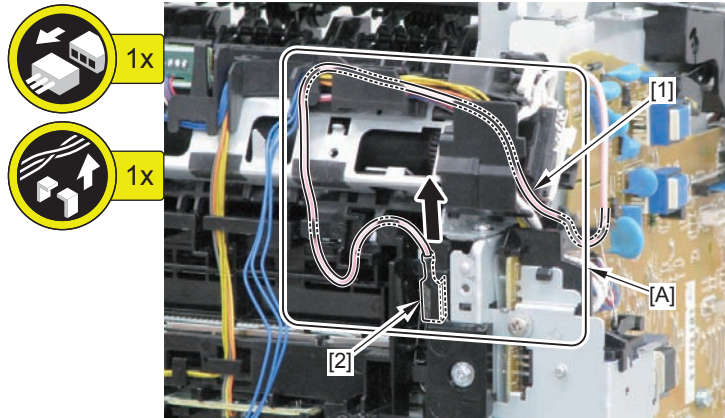

F-4-304

6) Remove the Harness Retaining Spring [1] from the 2 hooks [2].

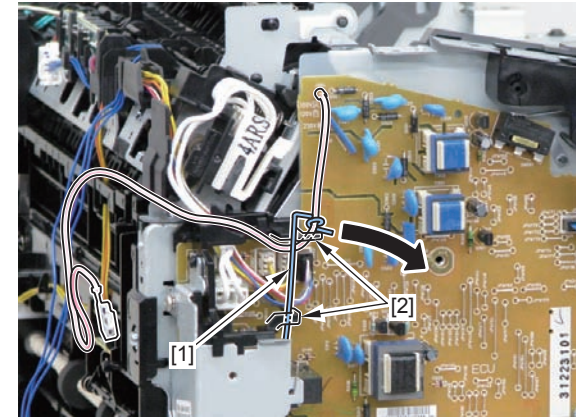

F-4-306

7) Disconnect the 4 connectors [1].

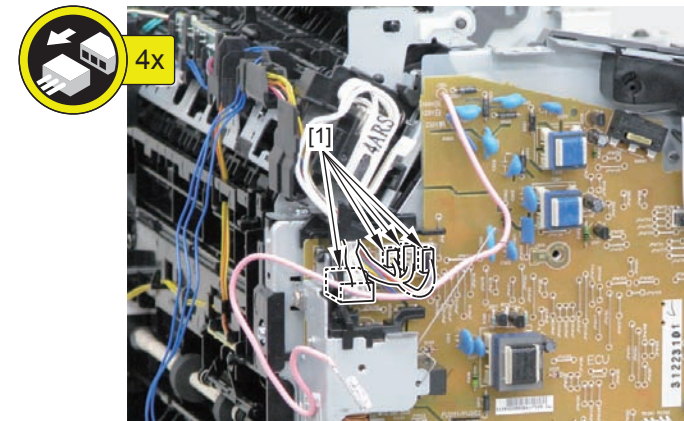

F-4-307

CAUTION:

Be sure that the terminal [2] is in contact with the Contact Spring [3].

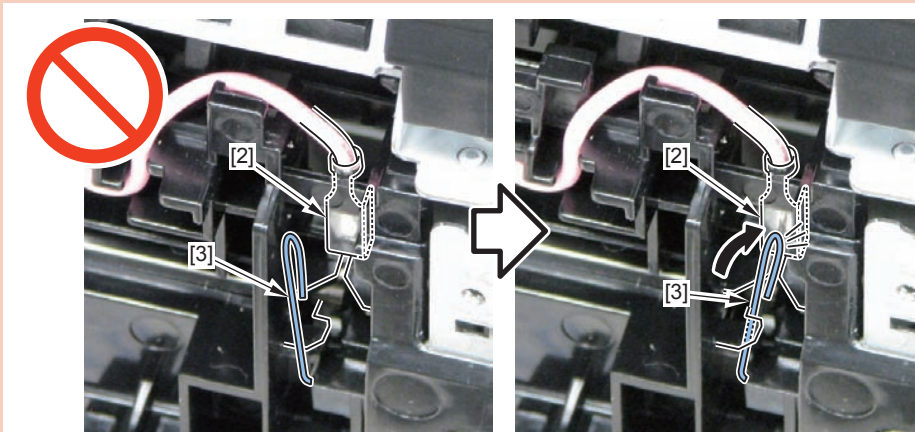

F-4-305

- 8) Free the harness [1] from the Harness Guide [A].
 - 9) Remove the Paper Leading Edge Sensor PCB [2].
- 2 Claws [3]

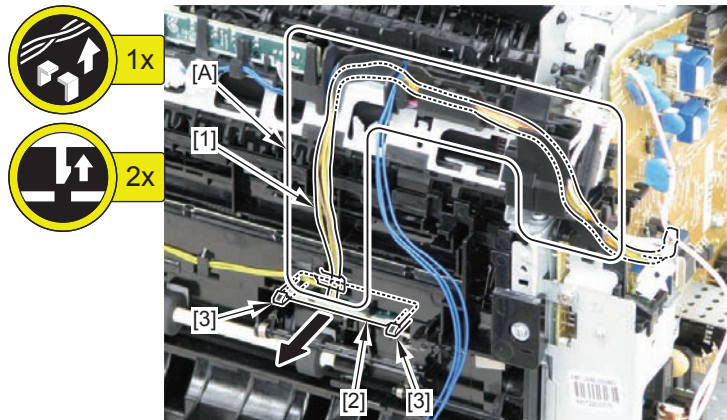

F-4-308

NOTE:

The following shows how to route the harness.

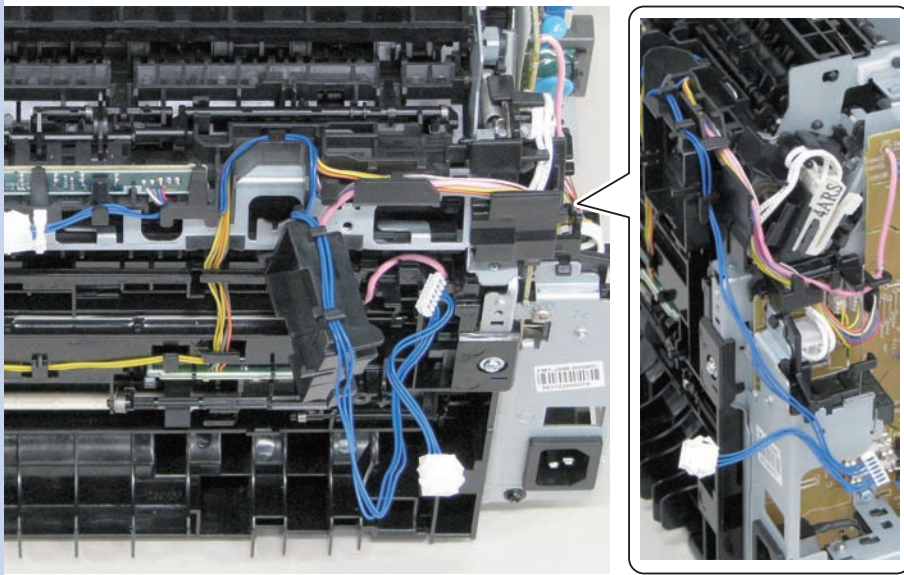

F-4-309

Removing the Fixing Delivery/Paper Width Sensor PCB (Duplex Model)

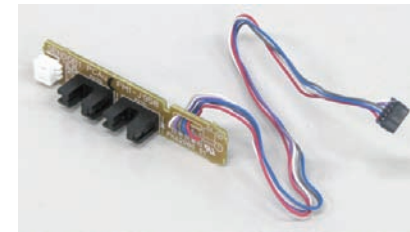

F-4-310

Preparation

- 1) Remove the Left Cover (Duplex Model) (Refer to page 4-86).
- 2-1) Remove the DADF Unit + Reader Unit (DADF Model) (Refer to page 4-27).
- 2-2) Remove the SADF Unit + Reader Unit (SADF Model) (Refer to page 4-51).
- 2-3) Remove the Copyboard Cover + Reader Unit (Copyboard Model) (Refer to page 4-76).
- 3) Remove the Right Cover (Duplex Model) (Refer to page 4-87).
- 4) Remove the Front Cover Unit (Duplex Model) (Refer to page 4-89).
- 5) Remove the Upper Cover Unit (Duplex Model) (Refer to page 4-89).
- 6) Remove the Duplex Feed Guide Unit (Duplex Model) (Refer to page 4-91).
- 7) Remove the Main Controller PCB (Duplex Model) (Refer to page 4-95).
- 8) Remove the FAX NCU PCB (FAX Model 120/230V) (Duplex Model) (Refer to page 4-107).
- 9) Remove the Edge Left Cooling Fan (Duplex Model) (Refer to page 4-99).

Procedure

1) Remove the Wireless LAN Unit [1] (Wifi Model).

- 1 Screw (black TP) [2]
- 2 Hooks [3]

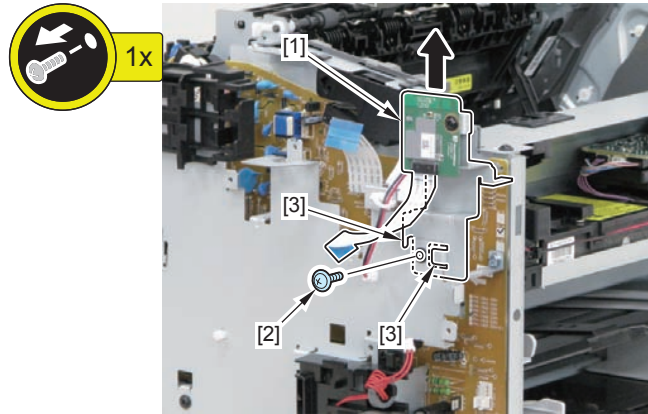

F-4-311

2) Remove the Main Controller PCB Installation Plate [1].

- 1 Relay Connector [2]
- Harness Guide [A]
- 1 Wire Saddle [3]
- 4 Screws (with washer) [4]
- 2 Screws (black TP) [5]

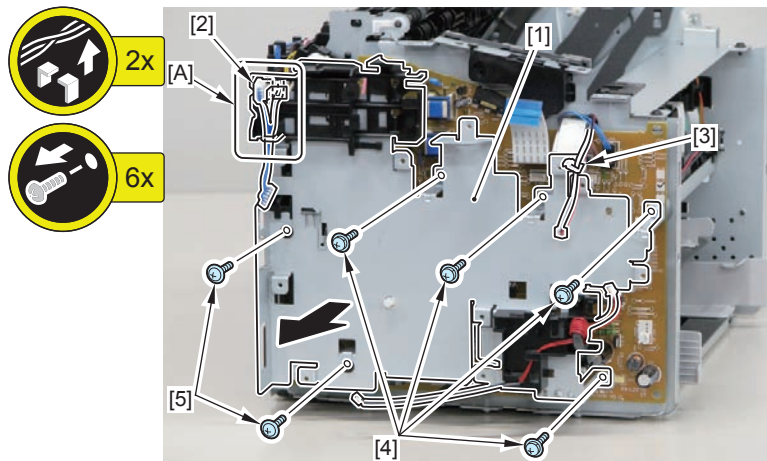

F-4-312

NOTE:

The Front Fixing Reinforcing Plate [1] should be removed before removing the Edge Left Cooling Fan Holder.

- 2 Screws (black TP) [2]

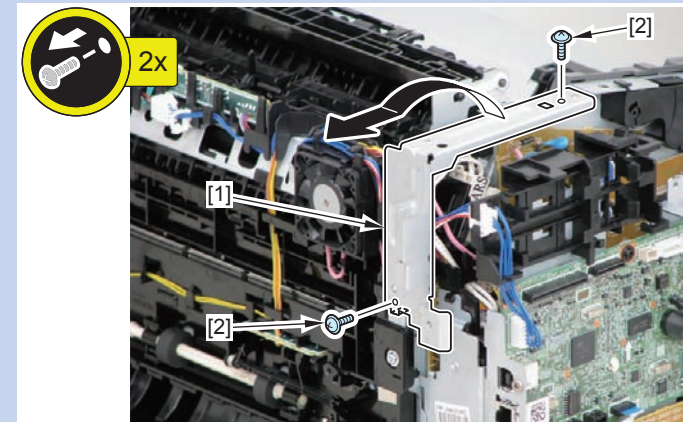

F-4-313

3) Free the harness [1] from the Harness Guide [A].

4) Remove the Edge Left Cooling Fan Holder [2].

- 1 Screw [3]

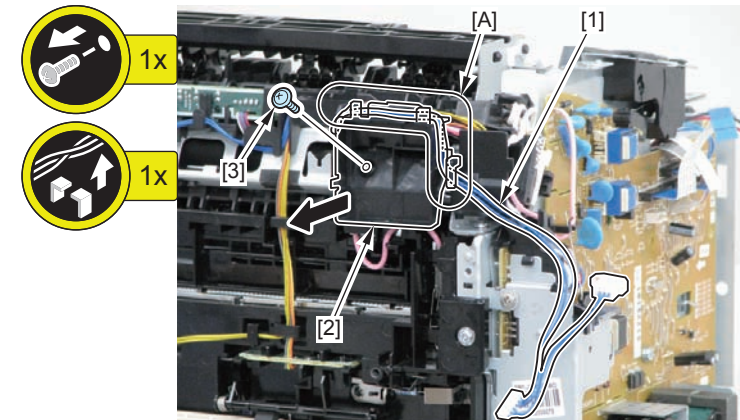

F-4-314

5) Free the harness [1] from the Harness Guide [A].

- 1 Terminal [2]

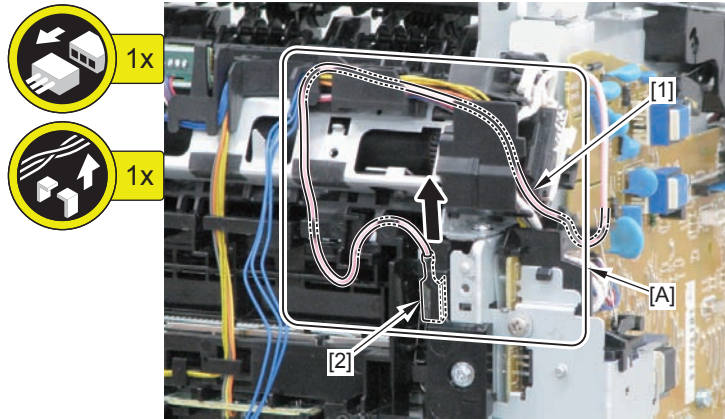

F-4-315

CAUTION:

Be sure that the terminal [2] is in contact with the Contact Spring [3].

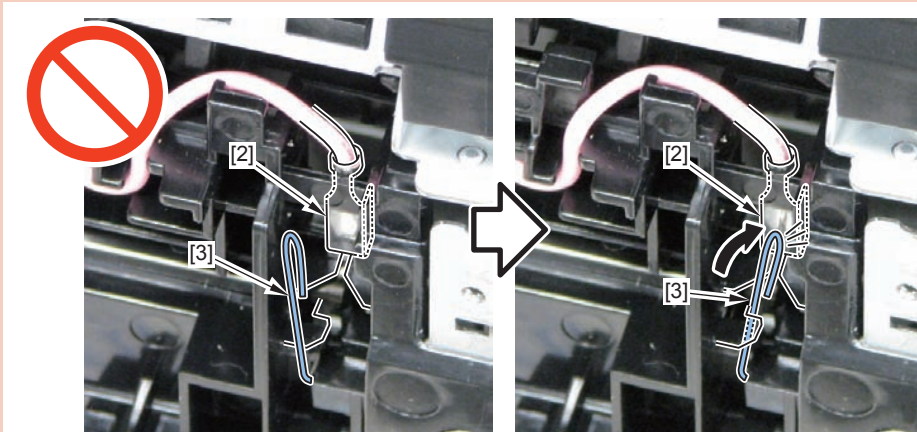

F-4-316

6) Remove the Harness Retaining Spring [1] from the 2 hooks [2].

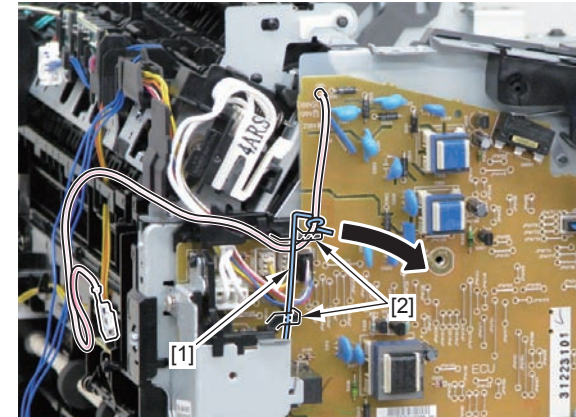

F-4-317

7) Disconnect the 4 connectors [1].

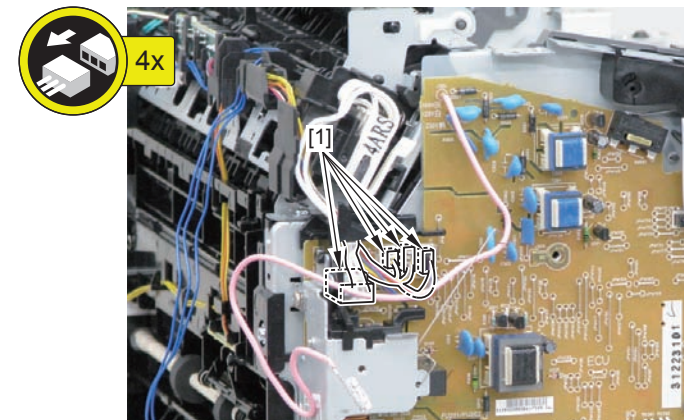

F-4-318

- 8) Free the harness [1] from the Harness Guide [A].
- 9) Remove the Fixing Delivery/Paper Width Sensor PCB [2].
 - 1 Connector [3]
 - 2 Claws [4]

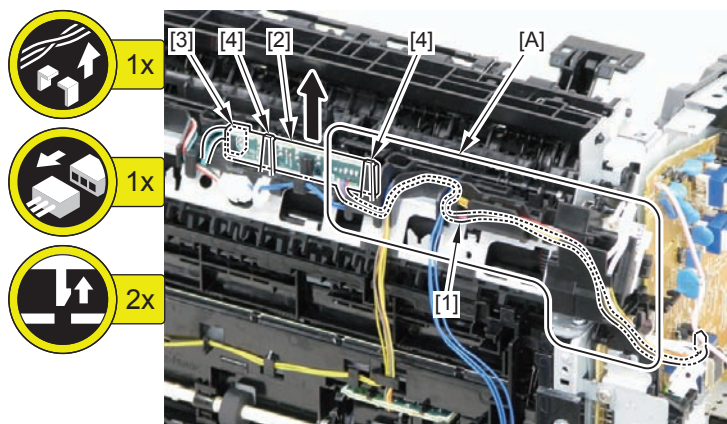

F-4-319

NOTE:

The following shows how to route the harness.

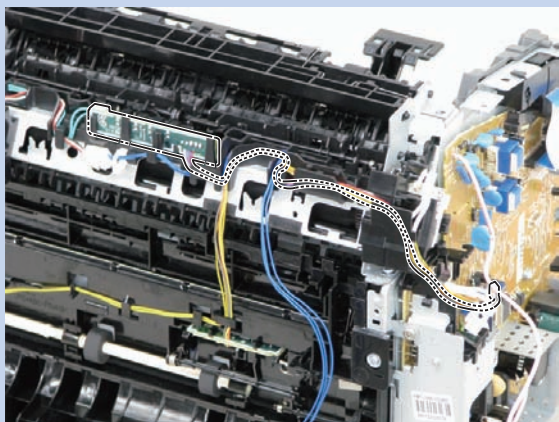

F-4-320

Removing the Toner Sensor and Multi Pickup Sensor Unit (Fax Model + Duplex Model)

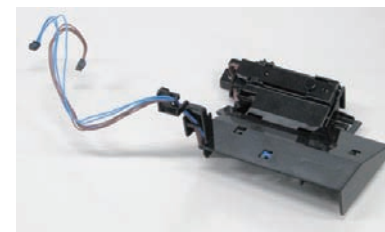

F-4-321

Preparation

- 1) Remove the Left Cover (Duplex Model) (Refer to page 4-86).
- 2-1) Remove the DADF Unit + Reader Unit (DADF Model) (Refer to page 4-27).
- 2-2) Remove the SADF Unit + Reader Unit (SADF Model) (Refer to page 4-51).
- 2-3) Remove the Copyboard Cover + Reader Unit (Copyboard Model) (Refer to page 4-76).
- 3) Remove the Right Cover (Duplex Model) (Refer to page 4-87).
- 4) Remove the Front Cover Unit (Duplex Model) (Refer to page 4-89).
- 5) Remove the Upper Cover Unit (Duplex Model) (Refer to page 4-89).

Procedure

1) Remove the Wireless LAN Unit [1] (Wifi Model).

- 1 Flat Cable [2]
- 1 Screw (black TP) [3]
- 2 Hooks [4]

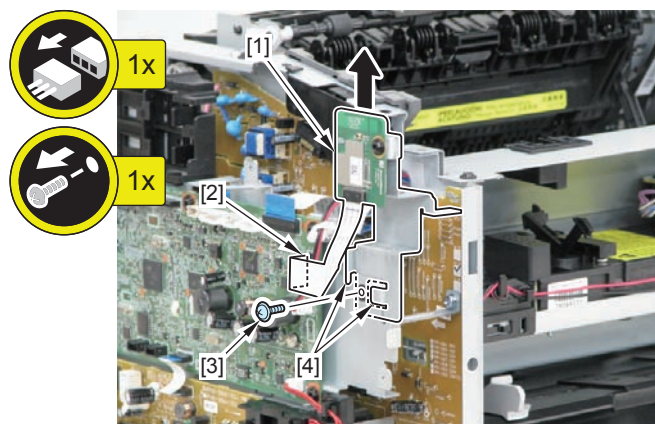

F-4-322

2) Remove the Scanner Cover [1].

- 2 Screws (black TP) [2]

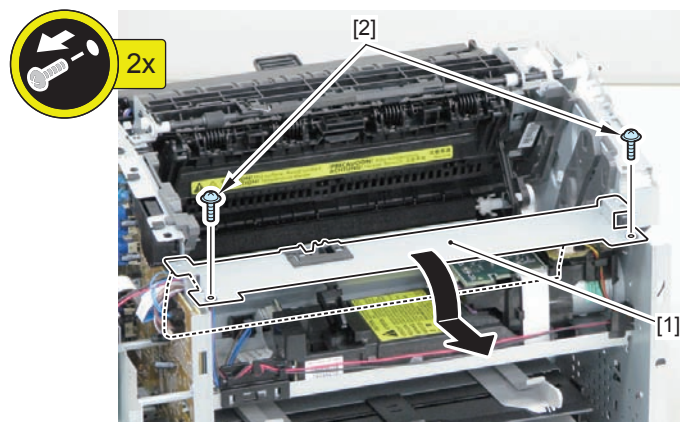

F-4-323

NOTE: How to assemble the Scanner Cover

- 1) Be sure to pass the Shutter Open/Close Lever [3] through the hole [A] of the Scanner Cover.

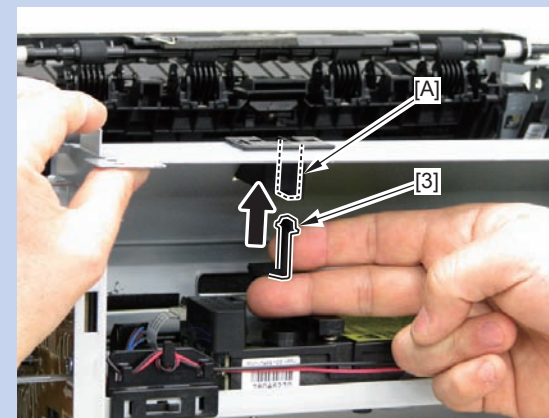

F-4-324

- 2) Be sure that the Shutter Open/Close Lever [3] can move vertically.

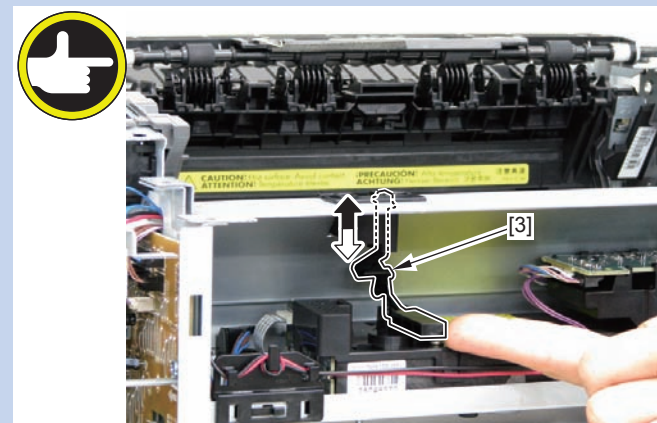

F-4-325

3) Pass the harness [1] through the hole [A] of the Left Side Plate to the inside.

- 1 Connector [2]
- 1 Connector [3] (Fax Model)

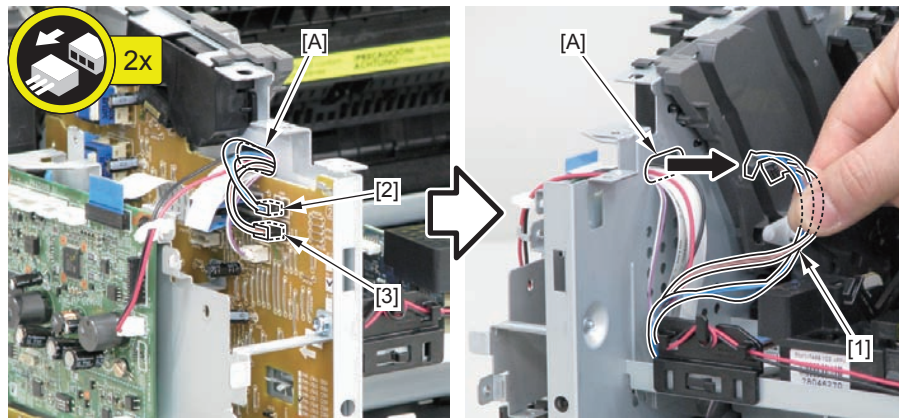

F-4-326

4) Remove the Multi Pickup Sensor Unit [1].

- 1 Wire Saddle [2]
- 1 Claw [3]
- 3 Hooks [4]

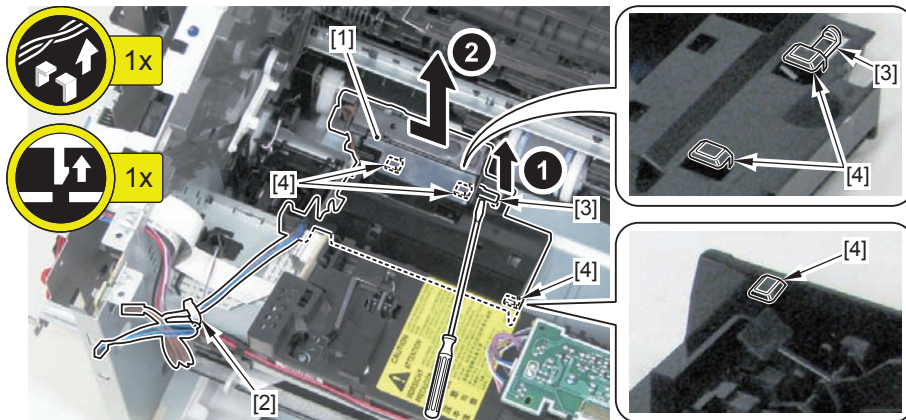

F-4-327

Removing the Speaker (Fax Model + Duplex Model)

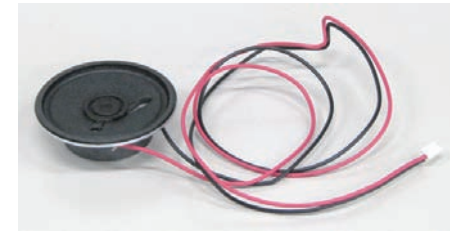

F-4-328

Preparation

- 1) Remove the Left Cover (Duplex Model) (Refer to page 4-86).
- 2) Remove the Right Cover (Duplex Model) (Refer to page 4-87).
- 3) Remove the Front Cover Unit (Duplex Model) (Refer to page 4-89).

Procedure

- 1) Disconnect the Speaker Harness [1], and pass it through the hole [A] of the Left Side Plate to the inside.

- 1 Connector [2]
- 1 Wire Saddle [3]

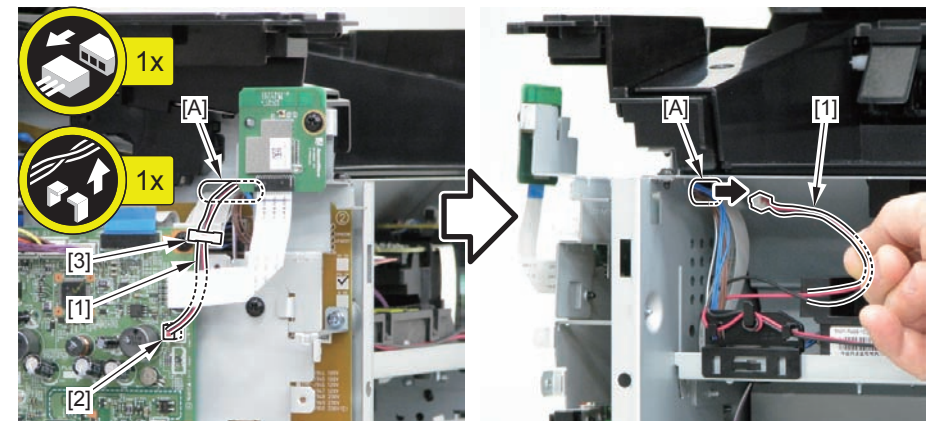

F-4-329

2) Free the Speaker Harness [1] from the Harness Guide [A], and pass it through the hole [B] of the Right Plate to the outside.

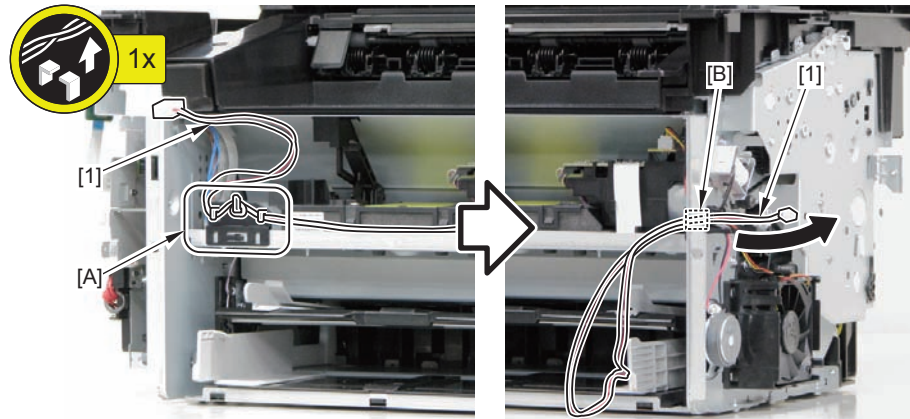

F-4-330

3) Remove the speaker [1].

- 1 Screw [2]
- 2 Hook[3]

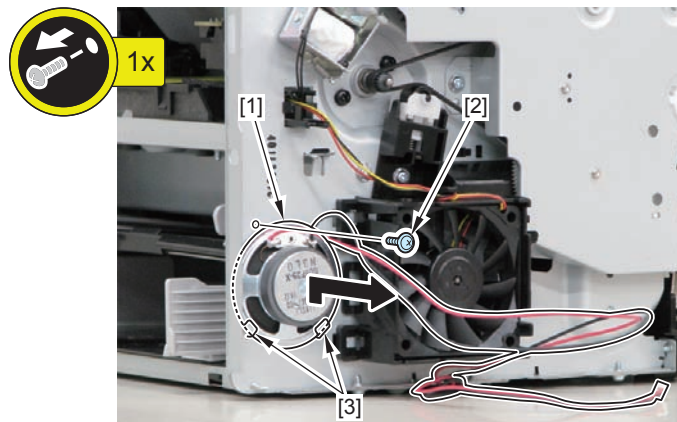

F-4-331

NOTE: How to assemble the speaker

Be sure to assemble it with the harness [1] routed upwards.

(Otherwise, the connector of the Speaker Harness cannot reach the Main Controller.)

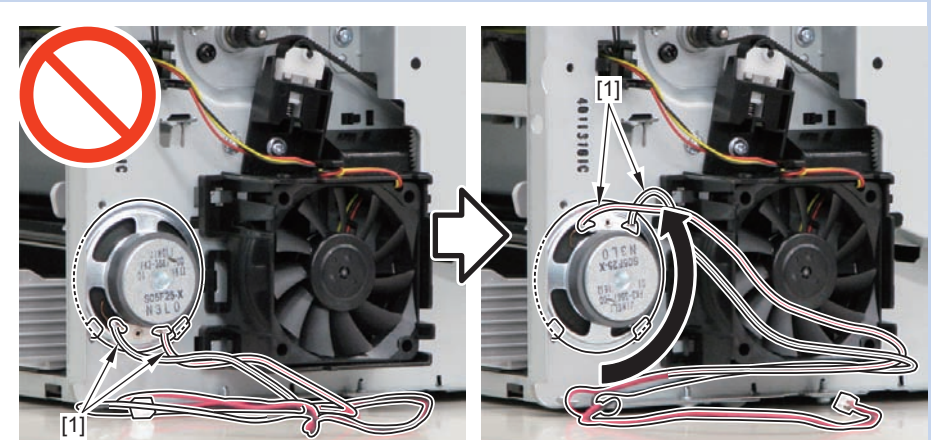

F-4-332

Laser Exposure System (Duplex Model)

Layout Drawing

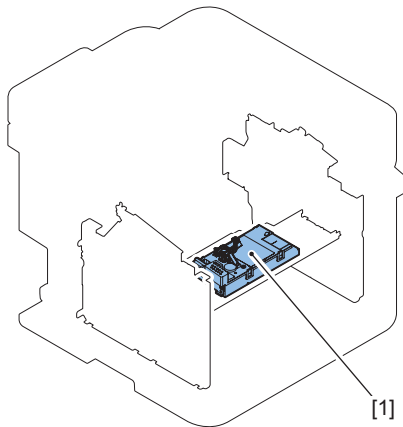

F-4-333

No.	Name	Reference	Remarks
[1]	Laser Scanner Unit	(Refer to page 4-118)	

T-4-42

Removing the Laser Scanner Unit (Duplex Model)



F-4-334

Preparation

- 1) Remove the Left Cover (Duplex Model) (Refer to page 4-86).
- 2-1) Remove the DADF Unit + Reader Unit (DADF Model) (Refer to page 4-27).
- 2-2) Remove the SADF Unit + Reader Unit (SADF Model) (Refer to page 4-51).
- 2-3) Remove the Copyboard Cover + Reader Unit (Copyboard Model) (Refer to page 4-76).
- 3) Remove the Right Cover (Duplex Model) (Refer to page 4-87).
- 4) Remove the Front Cover Unit (Duplex Model) (Refer to page 4-89).
- 5) Remove the Upper Cover Unit (Duplex Model) (Refer to page 4-89).

Procedure

CAUTION:

Do not disassemble the Laser Scanner Unit because it requires adjustment.

1) Remove the Scanner Cover [1].

- 2 Screws (black TP) [2]

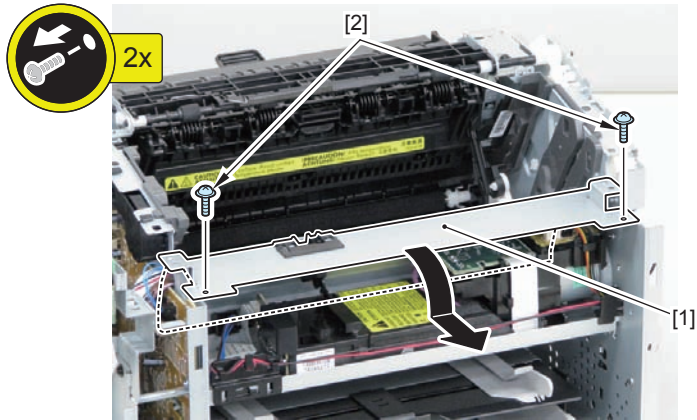

F-4-335

NOTE: How to assemble the Scanner Cover

- 1) Be sure to pass the Shutter Open/Close Lever [3] through the hole [A] of the Scanner Cover.

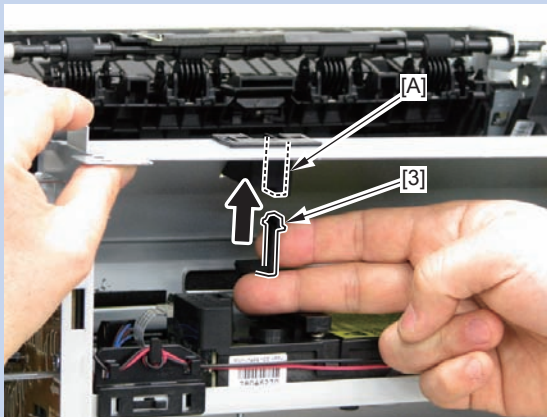

F-4-336

NOTE: How to assemble the Scanner Cover

- 2) Be sure that the Shutter Open/Close Lever [3] can move vertically.

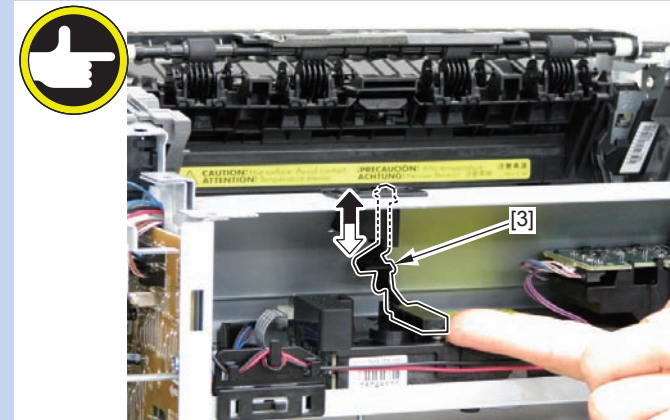

F-4-337

2) Move the Laser Scanner Unit [1].

- 4 Screws [2]

3) Remove the Laser Scanner Unit [1].

- 1 Flat Cable [3]
- 1 Sponge [4]
- 1 Connector [5]

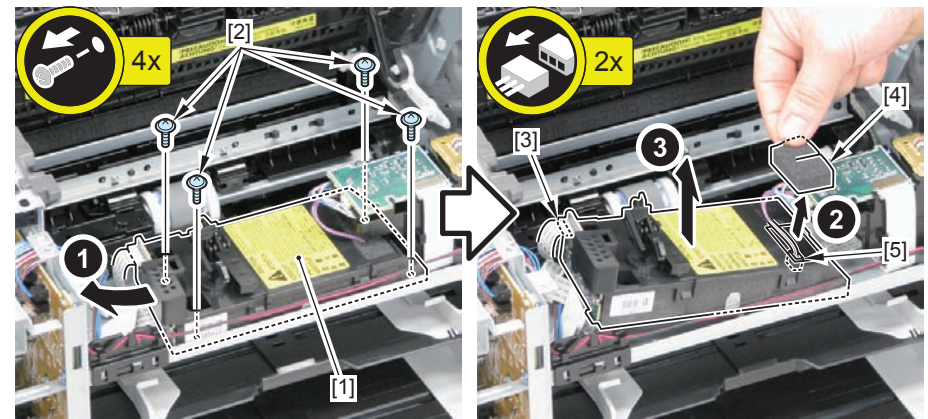

F-4-338

Image Formation System (Duplex Model)

Layout Drawing

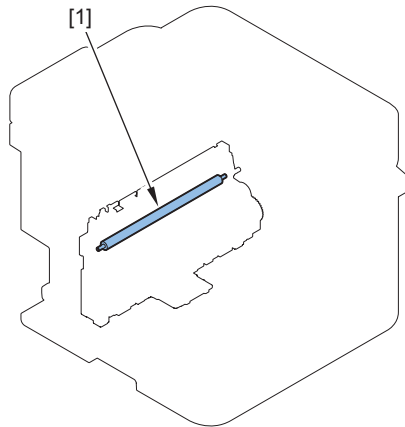

F-4-339

No.	Name	Reference	Remarks
[1]	Transfer Roller	(Refer to page 4-120)	

T-4-43

Removing the Transfer Roller (Duplex Model)



F-4-340

Procedure

CAUTION:

Do not touch the surface of the Transfer Roller.

- 1-1) Open the DADF Unit + Reader Unit [1] and Delivery Tray [2] (DADF Model).
- 1-2) Open the SADF Unit + Reader Unit [1] and Delivery Tray [2] (SADF Model).
- 1-3) Open the Copyboard Cover + Reader Unit [1] and Delivery Tray [2] (Copyboard Model).
- 2) Remove the bushing [3] of the Transfer Roller.
 - 2 Claws [4]

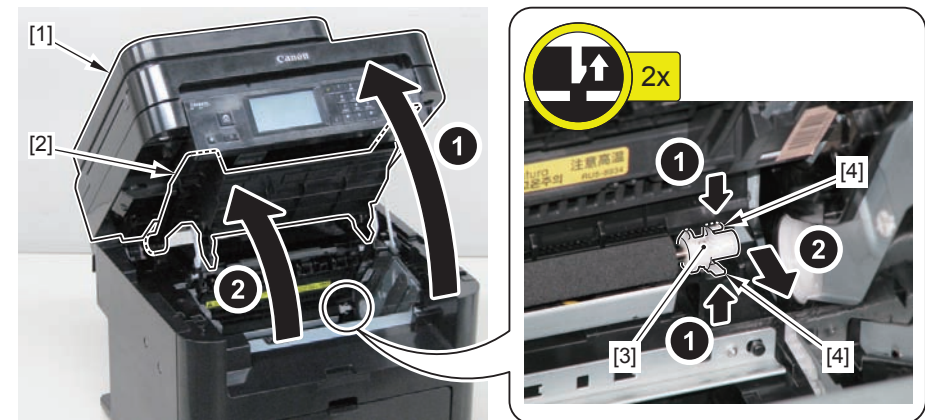

F-4-341

3) Hold both ends of the shaft [1] of the Transfer Roller, and remove the Transfer Roller [2].

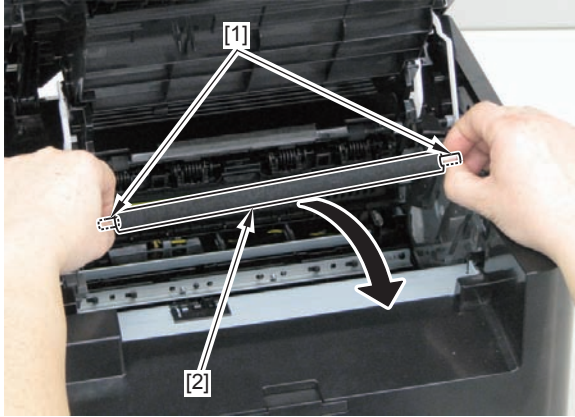

F-4-342

CAUTION:

Be sure that the bushing [1] is facing the correct direction when assembling.

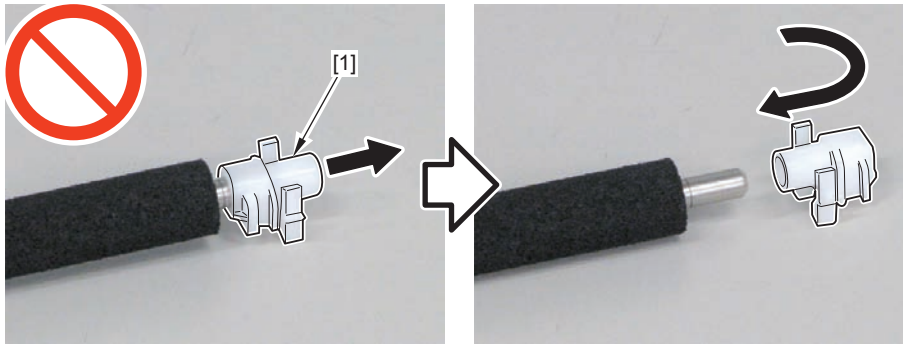

F-4-343

NOTE: How to assemble the Transfer Roller

Be sure to assemble it by aligning the spring [1] with the boss [2].

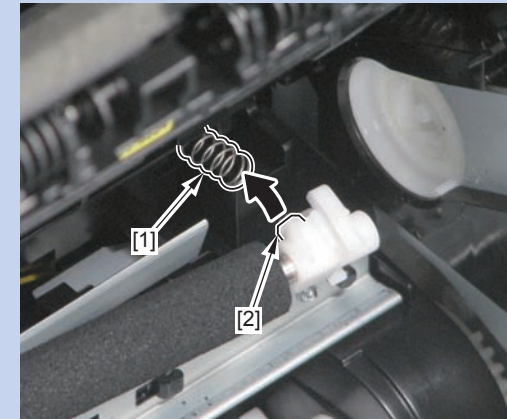

F-4-344

Fixing System (Duplex Model)

Layout Drawing

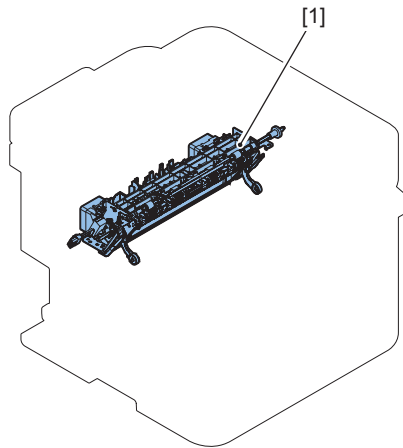

F-4-345

No.	Name	Reference	Remarks
[1]	Fixing Unit	(Refer to page 4-122)	

T-4-44

Removing the Fixing Assembly (Duplex Model)

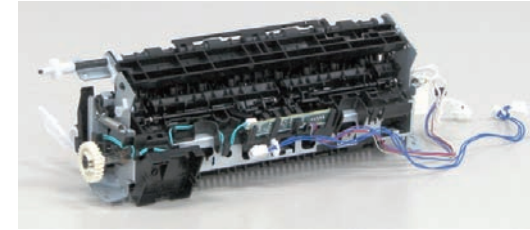

F-4-346

Preparation

- 1) Remove the Left Cover (Duplex Model) (Refer to page 4-86).
- 2-1) Remove the DADF Unit + Reader Unit (DADF Model) (Refer to page 4-27).
- 2-2) Remove the SADF Unit + Reader Unit (SADF Model) (Refer to page 4-51).
- 2-3) Remove the Copyboard Cover + Reader Unit (Copyboard Model) (Refer to page 4-76).
- 3) Remove the Right Cover (Duplex Model) (Refer to page 4-87).
- 4) Remove the Front Cover Unit (Duplex Model) (Refer to page 4-89).
- 5) Remove the Upper Cover Unit (Duplex Model) (Refer to page 4-89).
- 6) Remove the Duplex Feed Guide Unit (Duplex Model) (Refer to page 4-91).
- 7) Remove the Main Controller PCB (Duplex Model) (Refer to page 4-95).
- 8) Remove the FAX NCU PCB (FAX Model 120/230V) (Duplex Model) (Refer to page 4-107).
- 9) Remove the Edge Left Cooling Fan (Duplex Model) (Refer to page 4-99).
- 10) Remove the Edge Right Cooling Fan (Duplex Model) (Refer to page 4-101).

Procedure

CAUTION:

- Be sure to start work after the Fixing Assembly is cooled down enough.
- The Fixing Assembly right after printing may cause burn injury.
- Do not disassemble the Fixing Assembly because it requires adjustment.

1) Remove the Wireless LAN Unit [1] (Wifi Model).

- 1 Screw (black TP) [2]
- 2 Hooks [3]

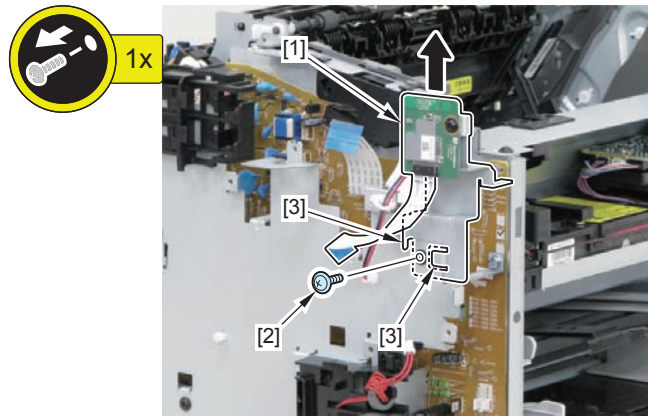

F-4-347

2) Remove the Main Controller PCB Installation Plate [1].

- 1 Relay Connector [2]
- Harness Guide [A]
- 1 Wire Saddle [3]
- 4 Screws (with washer) [4]
- 2 Screws (black TP) [5]

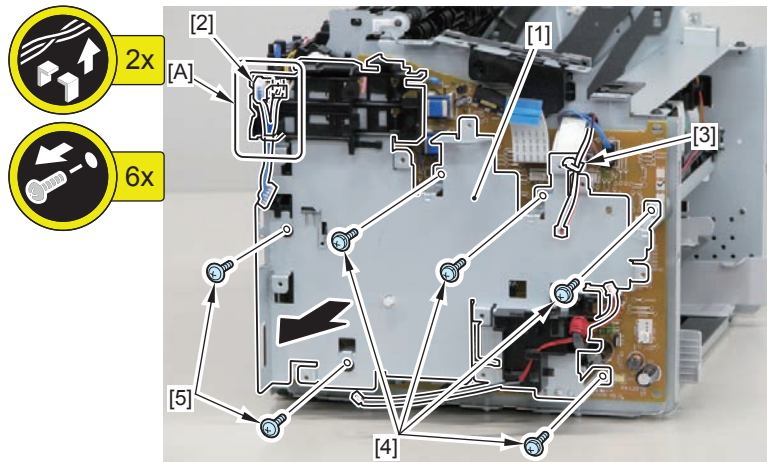

F-4-348

NOTE:

The Front Fixing Reinforcing Plate [1] should be removed before removing the Edge Left Cooling Fan Holder.

- 2 Screws (black TP) [2]

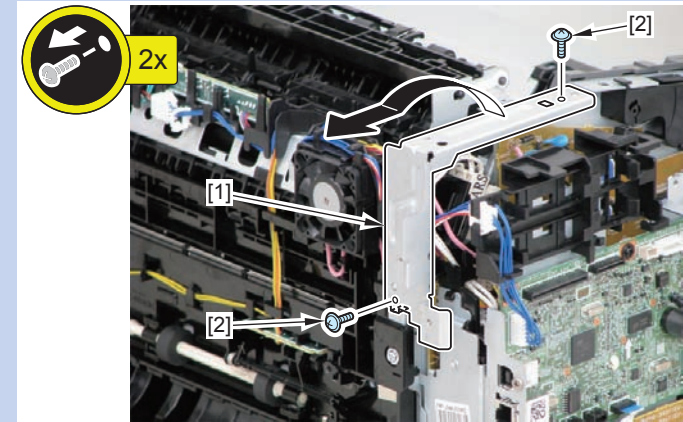

F-4-349

3) Free the harness [1] from the Harness Guide [A].

4) Remove the Edge Left Cooling Fan Holder [2].

- 1 Screw [3]

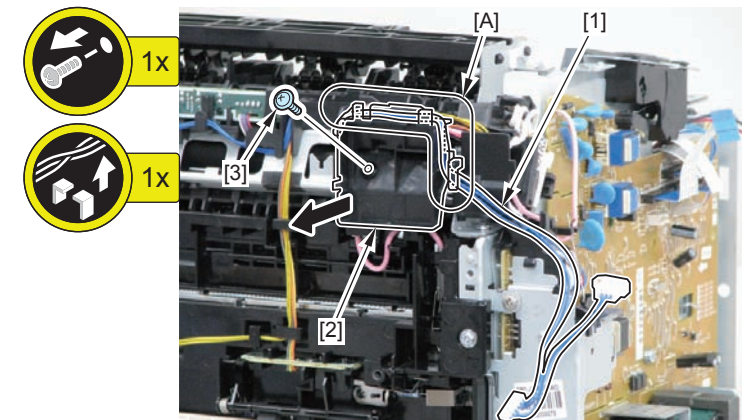

F-4-350

5) Free the harness [1] from the Harness Guide [A].

- 1 Terminal [2]

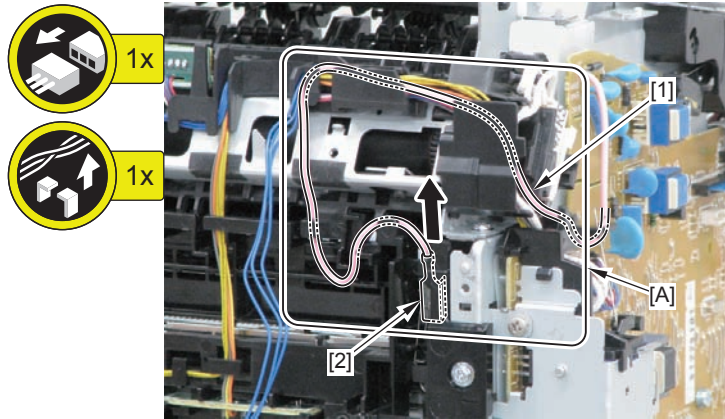

F-4-351

6) Remove the Harness Retaining Spring [1] from the 2 hooks [2].

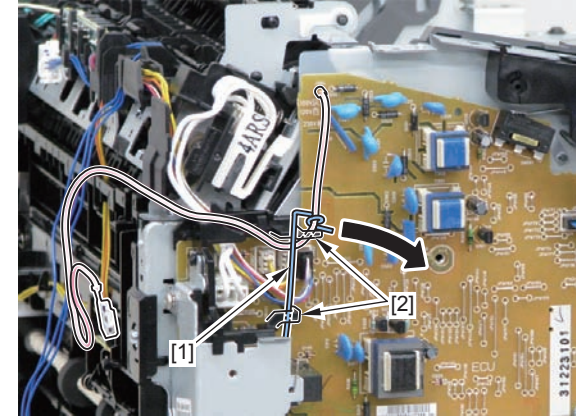

F-4-353

7) Disconnect the 4 connectors [1].

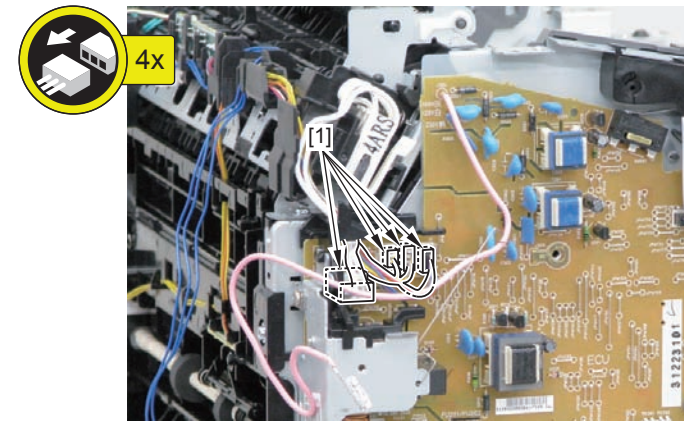

F-4-354

CAUTION:

Be sure that the terminal [2] is in contact with the Contact Spring [3].

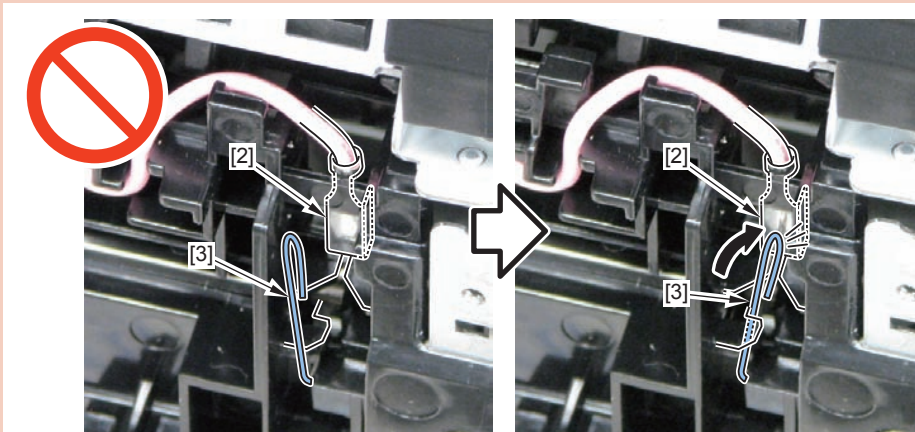

F-4-352

8) Free the harness [1] from the Harness Guide [A].

9) Free the Fixing Harness [2] from the Harness Holder [3].

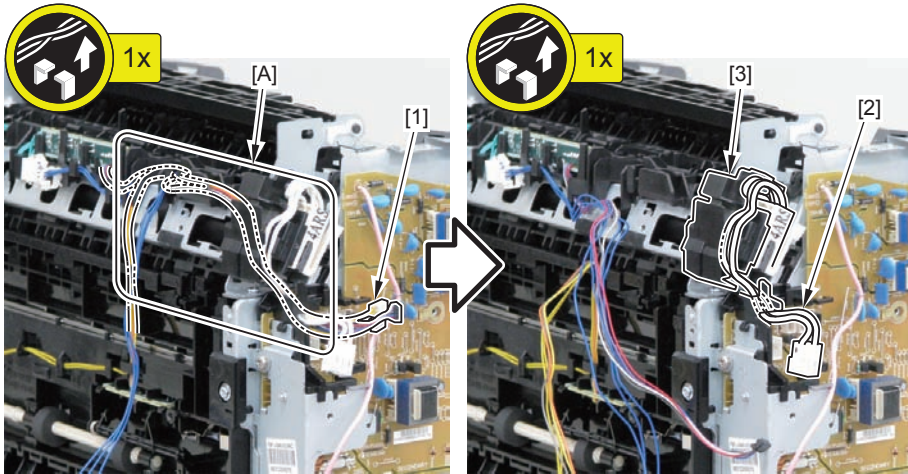

F-4-355

10) Remove the Harness Holder [1].

• 1 Claw [2]

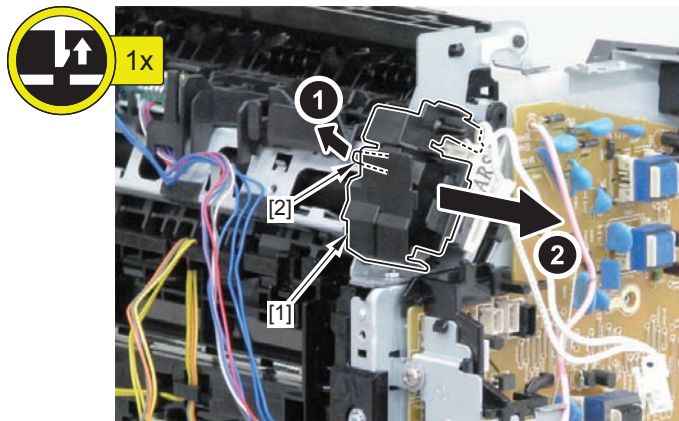

F-4-356

11) Remove the Rear Reinforcing Plate [1].

• 2 Screws (black TP) [2]

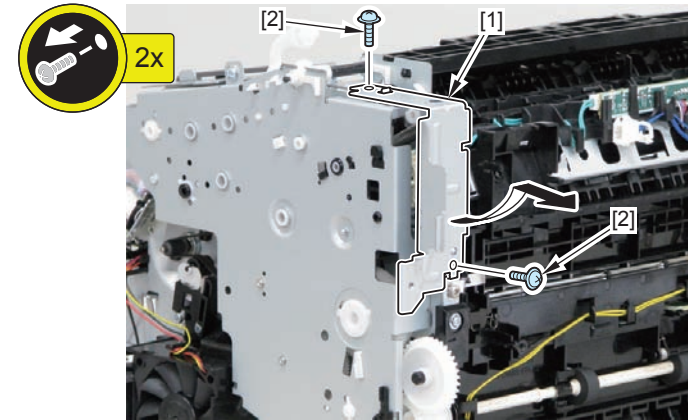

F-4-357

12) Remove the Shaft Support [1] of the Delivery Roller.

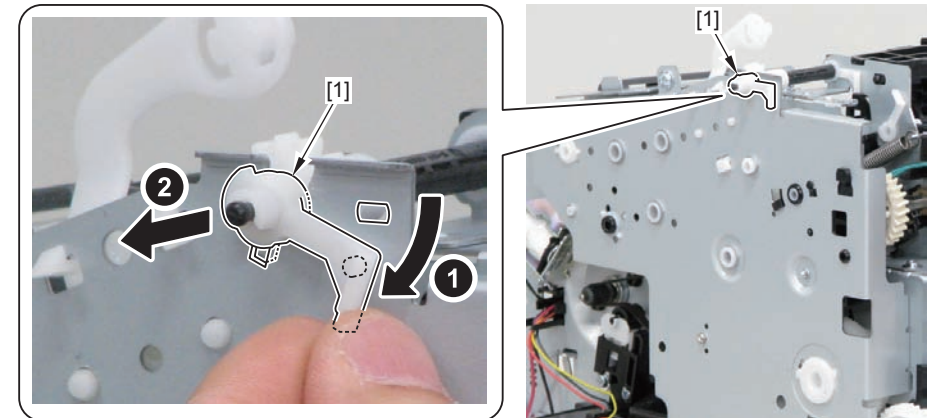

F-4-358

13) Remove the Fixing Assembly [1].

- 3 Screws [2]

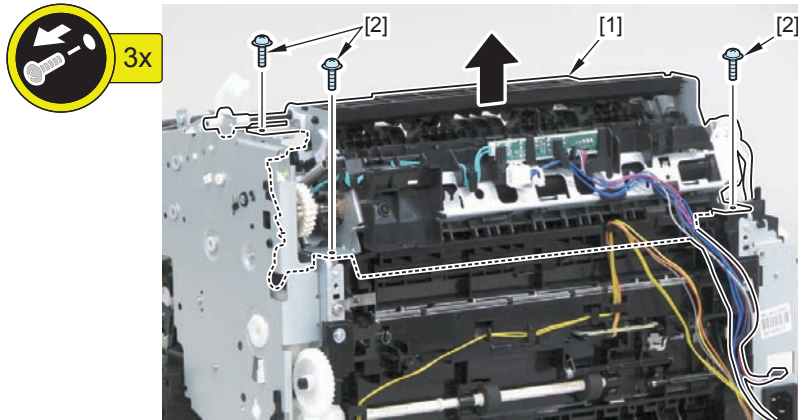

F-4-359

NOTE: How to install the Fixing Harness

- 1) Wrap the Fixing Harness [2] around the protrusion [1] of the Harness Holder.
- 2) Pass it through the Harness Guide [A], and then connect the connector [3].

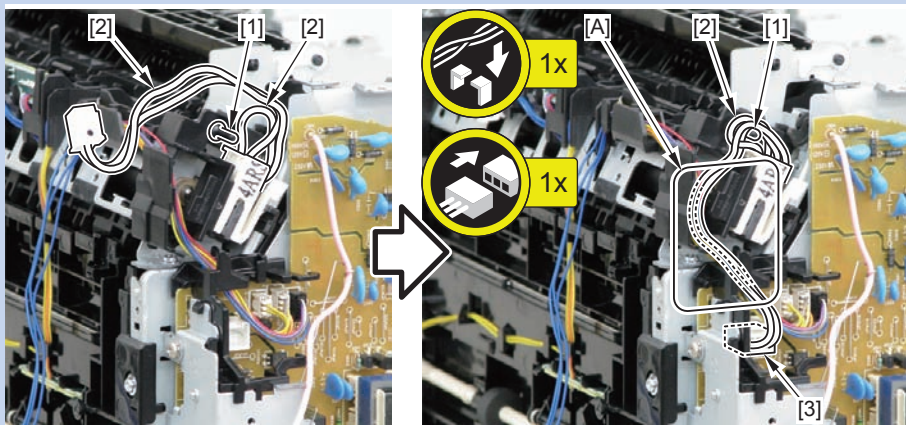

F-4-360

NOTE:

The following shows how to route the harness.

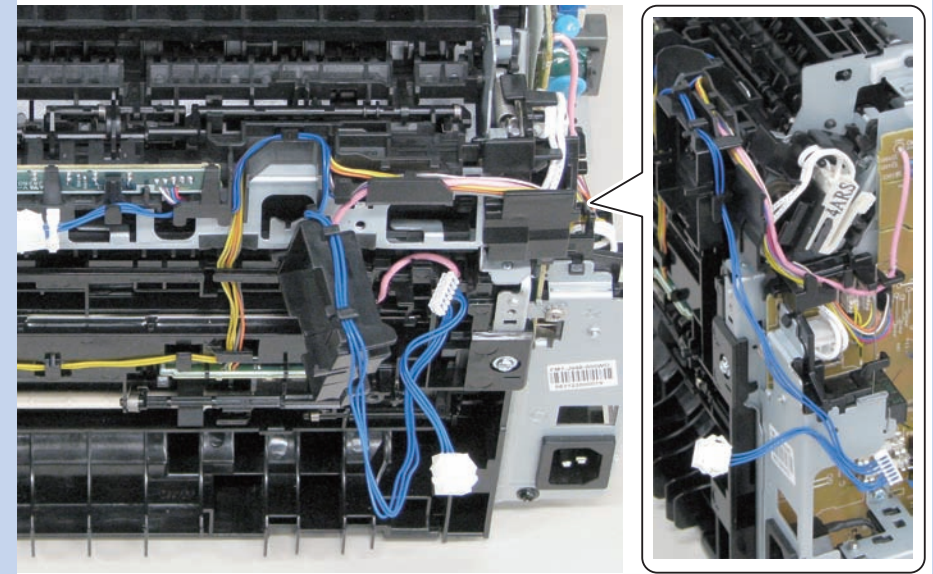

F-4-361

Pickup Feed System (Duplex Model)

Layout Drawing

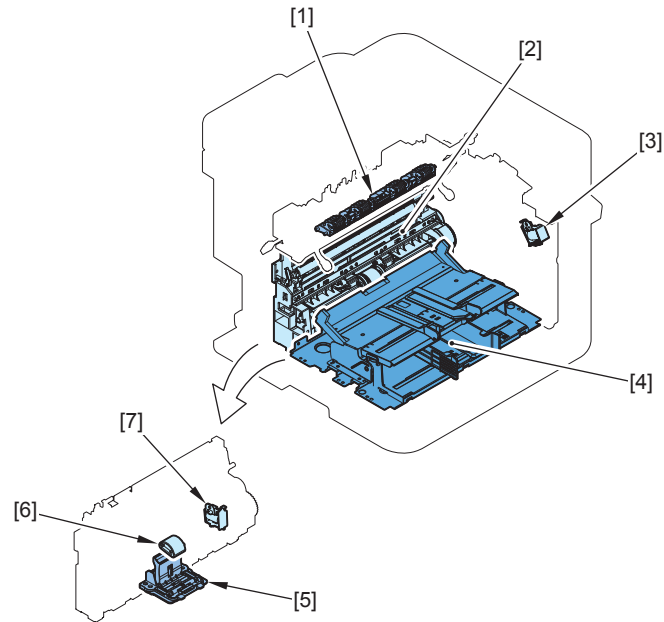

F-4-362

No.	Name	Reference	Remarks
[1]	Delivery Slave Roller Unit	(Refer to page 4-136)	
[2]	Pickup Unit	(Refer to page 4-127)	
[3]	Duplex Solenoid	(Refer to page 4-141)	
[4]	Pickup Tray Unit	(Refer to page 4-132)	
[5]	Separation Pad	(Refer to page 4-135)	
[6]	Pickup Roller	(Refer to page 4-134)	
[7]	Pickup Solenoid	(Refer to page 4-137)	

T-4-45

Removing the Pickup Unit (Duplex Model)

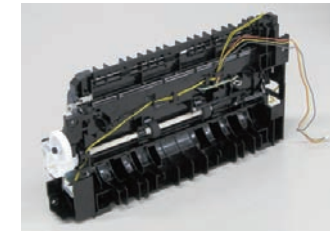

F-4-363

Preparation

- 1) Remove the Left Cover (Duplex Model) (Refer to page 4-86).
- 2-1) Remove the DADF Unit + Reader Unit (DADF Model) (Refer to page 4-27).
- 2-2) Remove the SADF Unit + Reader Unit (SADF Model) (Refer to page 4-51).
- 2-3) Remove the Copyboard Cover + Reader Unit (Copyboard Model) (Refer to page 4-76).
- 3) Remove the Right Cover (Duplex Model) (Refer to page 4-87).
- 4) Remove the Front Cover Unit (Duplex Model) (Refer to page 4-89).
- 5) Remove the Upper Cover Unit (Duplex Model) (Refer to page 4-89).
- 6) Remove the Duplex Feed Guide Unit (Duplex Model) (Refer to page 4-91).
- 7) Remove the Main Controller PCB (Duplex Model) (Refer to page 4-95).
- 8) Remove the FAX NCU PCB (FAX Model 120/230V) (Duplex Model) (Refer to page 4-107).
- 9) Remove the Edge Left Cooling Fan (Duplex Model) (Refer to page 4-99).
- 10) Remove the Separation Pad (Duplex Model) (Refer to page 4-135).

Procedure

1) Remove the Wireless LAN Unit [1] (Wifi Model).

- 1 Screw (black TP) [2]
- 2 Hooks [3]

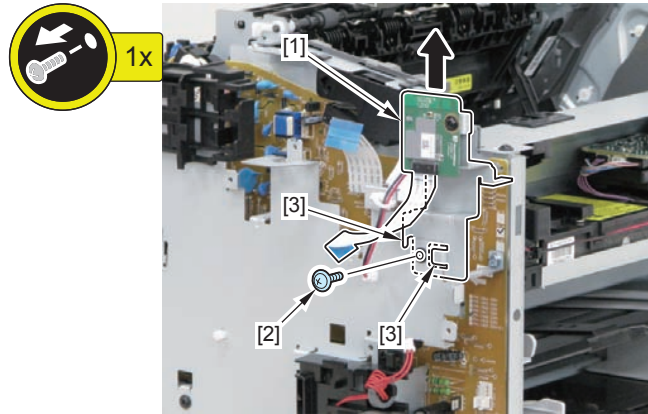

F-4-364

2) Remove the Main Controller PCB Installation Plate [1].

- 1 Relay Connector [2]
- Harness Guide [A]
- 1 Wire Saddle [3]
- 4 Screws (with washer) [4]
- 2 Screws (black TP) [5]

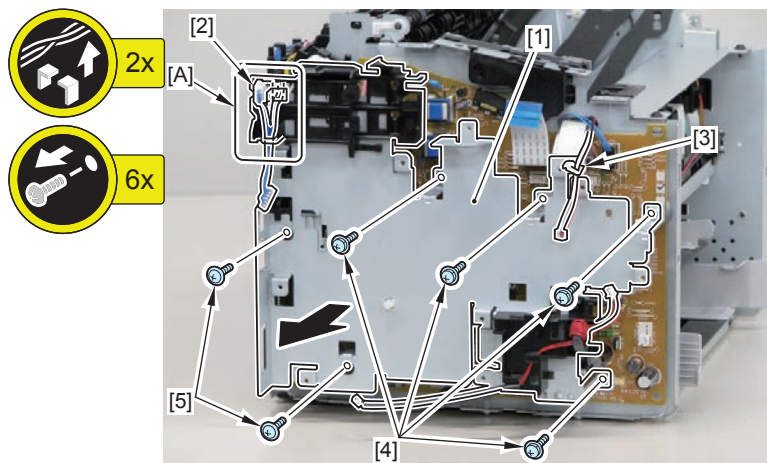

F-4-365

NOTE:

The Front Fixing Reinforcing Plate [1] should be removed before removing the Edge Left Cooling Fan Holder.

- 2 Screws (black TP) [2]

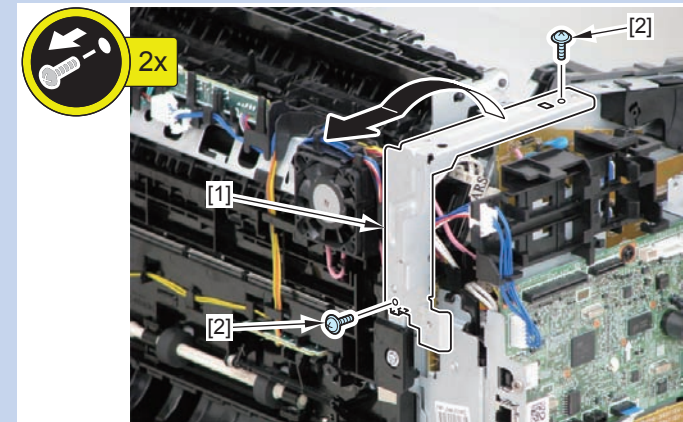

F-4-366

3) Free the harness [1] from the Harness Guide [A].

4) Remove the Edge Left Cooling Fan Holder [2].

- 1 Screw [3]

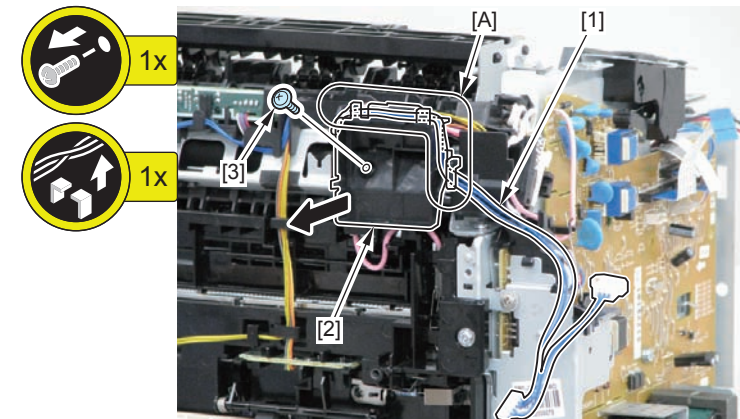

F-4-367

5) Free the harness [1] from the Harness Guide [A].

- 1 Terminal [2]

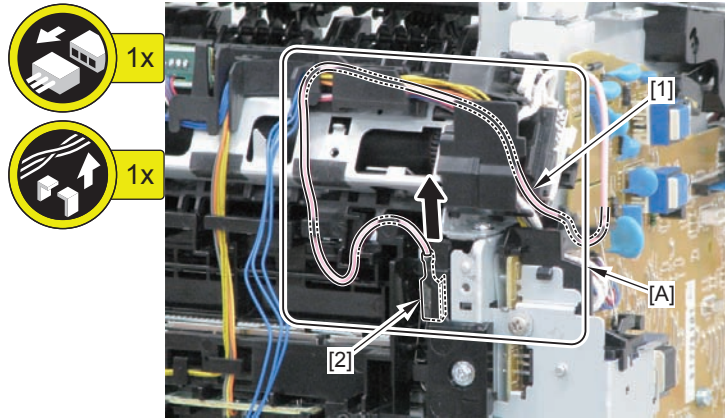

CAUTION:

Be sure that the terminal [2] is in contact with the Contact Spring [3].

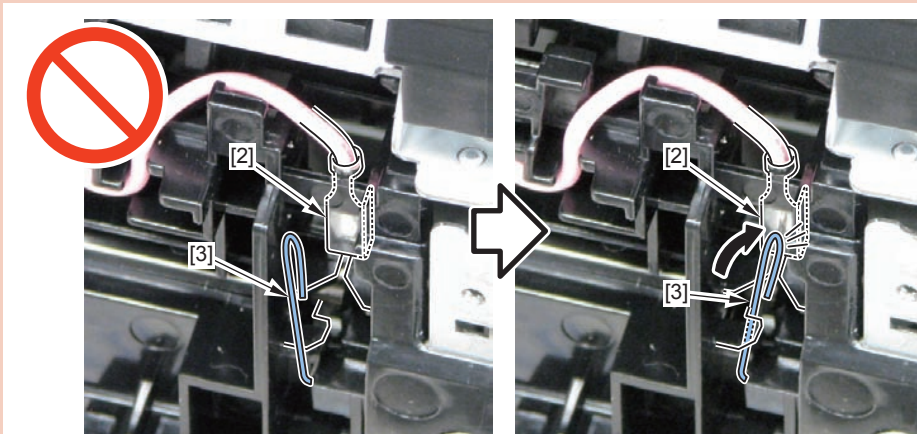

6) Remove the Harness Retaining Spring [1] from the 2 hooks [2].

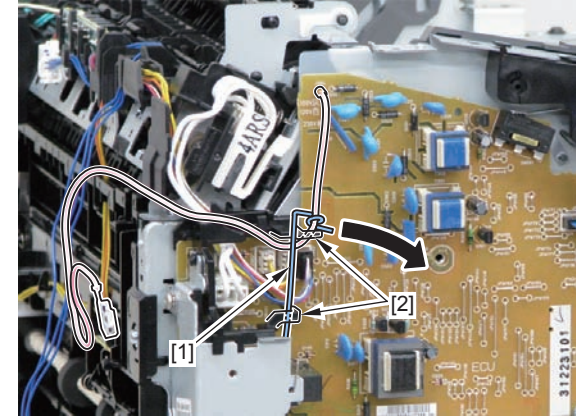

7) Disconnect the 4 connectors [1].

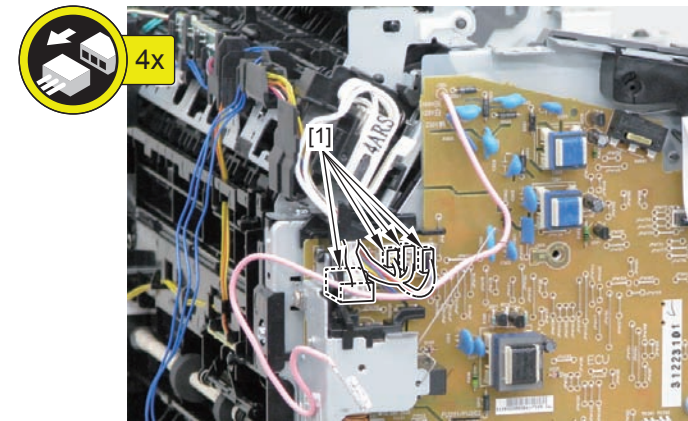

8) Free the harness [1] from the Harness Guide [A].

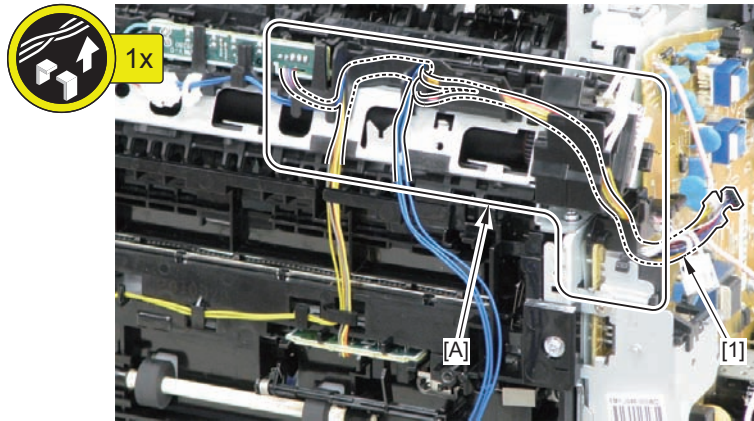

F-4-372

10) Turn the machine so that it is placed with its front side down.

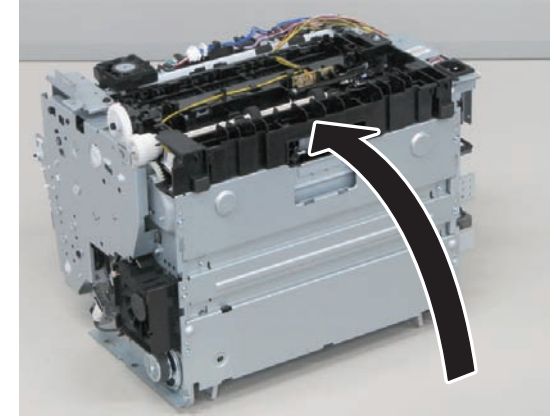

F-4-374

9) Remove the Shaft Retainer [1].

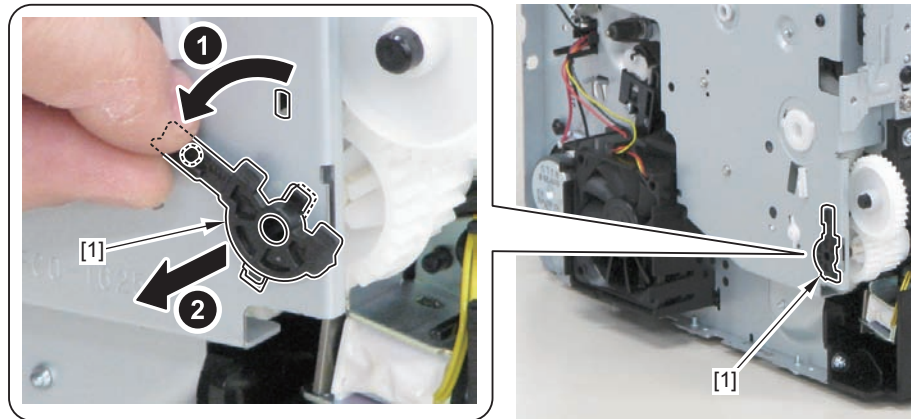

F-4-373

11) Remove the 6 screws (TP) [1] and the screw (with toothed lock washer) [2].

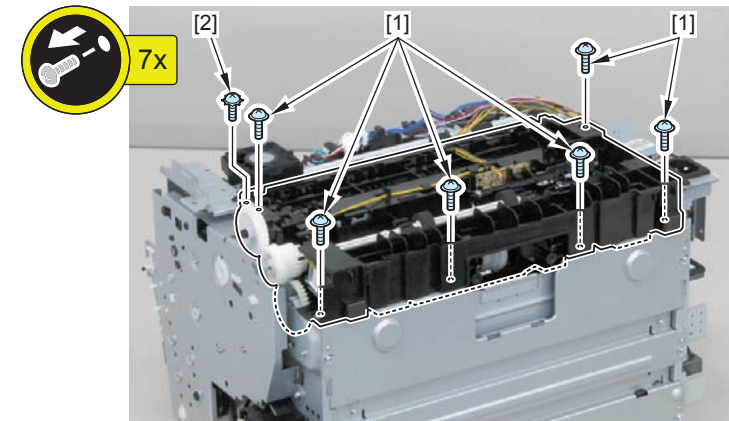

F-4-375

12) Remove the Pickup Unit [2] while holding the Pickup Unit [1] toward the front.

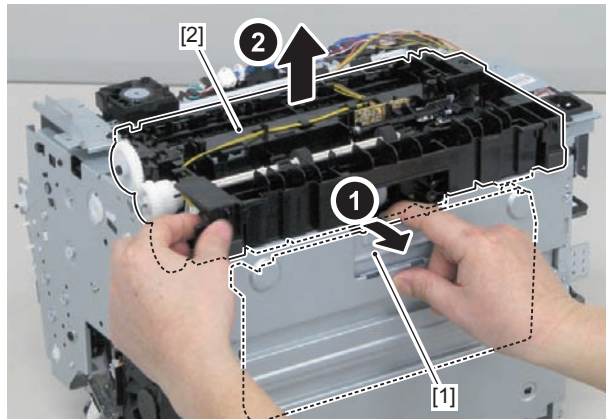

F-4-376

CAUTION:

- When installing the Pickup Unit [1], be sure that the Contact Spring [2] is in contact with the [A] part.
- Be sure to make the contact point [3] of the grounding come in contact with the [B] part.
- Be sure to install the Pickup Unit while holding the Pickup Tray [4] toward the front.
(This is because the tension of the spring is applied to the Pickup Tray.)

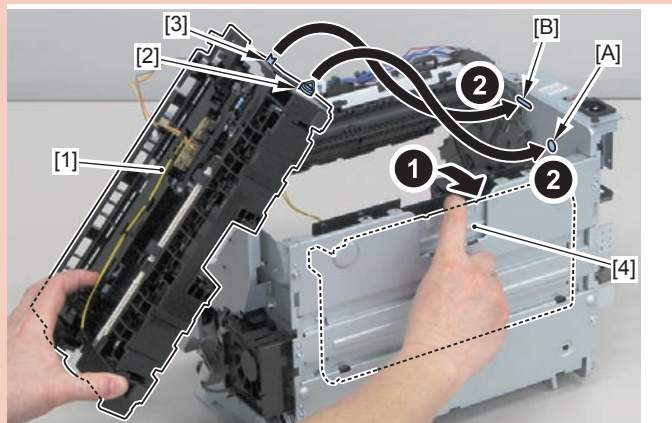

F-4-377

NOTE:

The following shows how to route the harness.

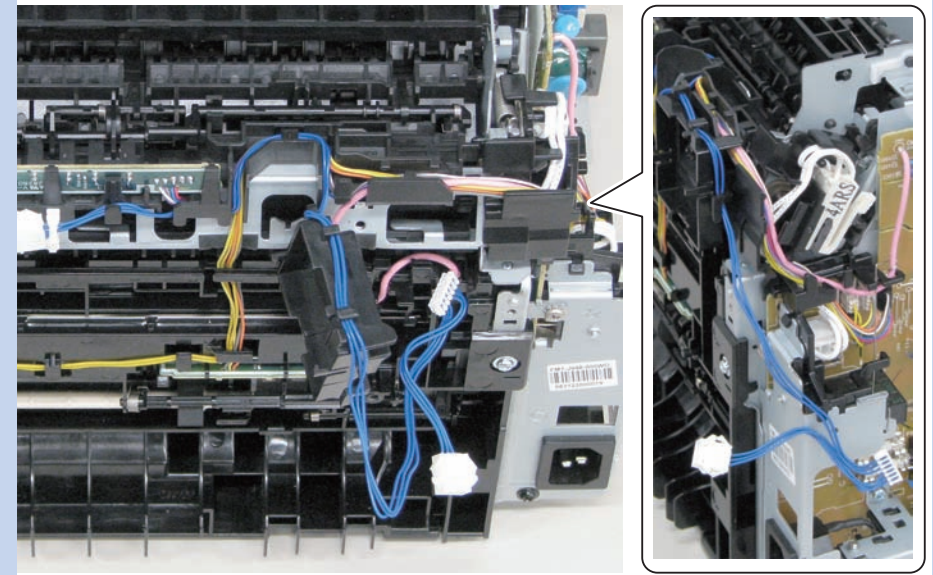

F-4-378

Removing the Pickup Tray Unit (Duplex Model)

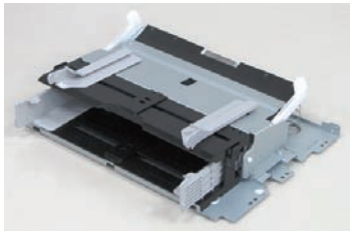

F-4-379

2) Remove the Pickup Unit [2] while holding the Pickup Tray Unit [1] toward the front.

- 2 Boss Holes [3]
- 2 Hooks [4]
- 2 Bosses [5]

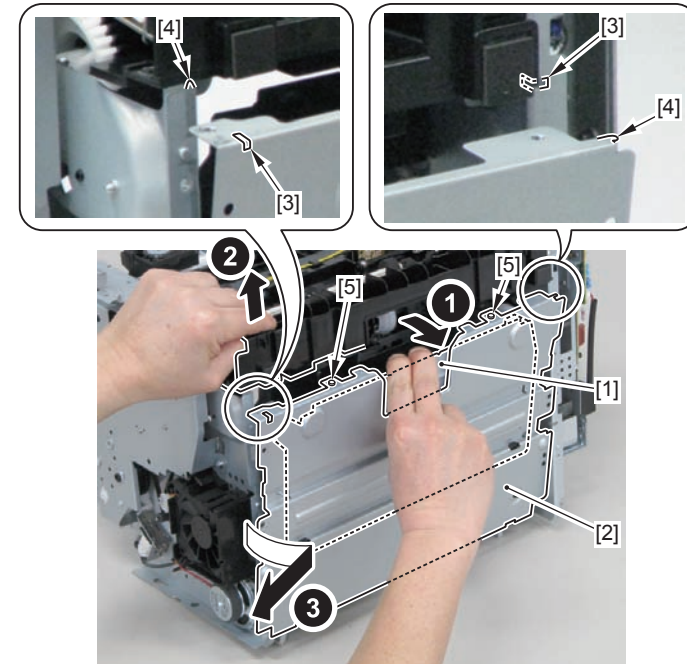

F-4-381

Preparation

- 1) Remove the Left Cover (Duplex Model) (Refer to page 4-86).
- 2-1) Remove the DADF Unit + Reader Unit (DADF Model) (Refer to page 4-27).
- 2-2) Remove the SADF Unit + Reader Unit (SADF Model) (Refer to page 4-51).
- 2-3) Remove the Copyboard Cover + Reader Unit (Copyboard Model) (Refer to page 4-76).
- 3) Remove the Right Cover (Duplex Model) (Refer to page 4-87).
- 4) Remove the Front Cover Unit (Duplex Model) (Refer to page 4-89).
- 5) Remove the Upper Cover Unit (Duplex Model) (Refer to page 4-89).
- 6) Remove the Duplex Feed Guide Unit (Duplex Model) (Refer to page 4-91).
- 7) Remove the Separation Pad (Duplex Model) (Refer to page 4-135).

Procedure

- 1) Remove the 4 screws (black TP) [1] and the 6 screws [2].

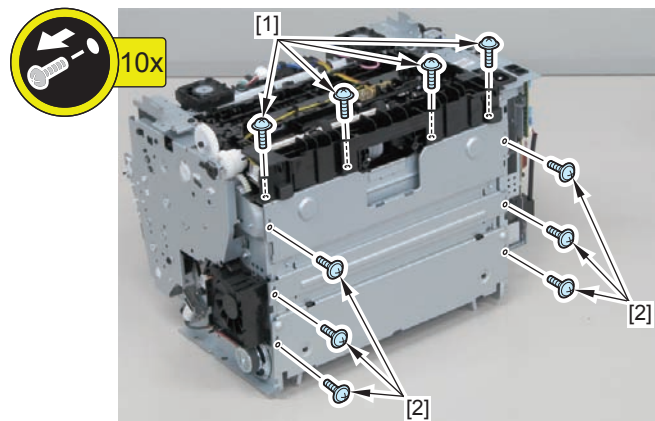

F-4-380

NOTE: How to assemble the Pickup Tray Unit

- 1) While holding the pickup tray [1] together, assemble it by aligning the 2 hooks [4] with the 2 Boss Holes [3] and the 2 bosses [5] with the Pickup Unit [2].

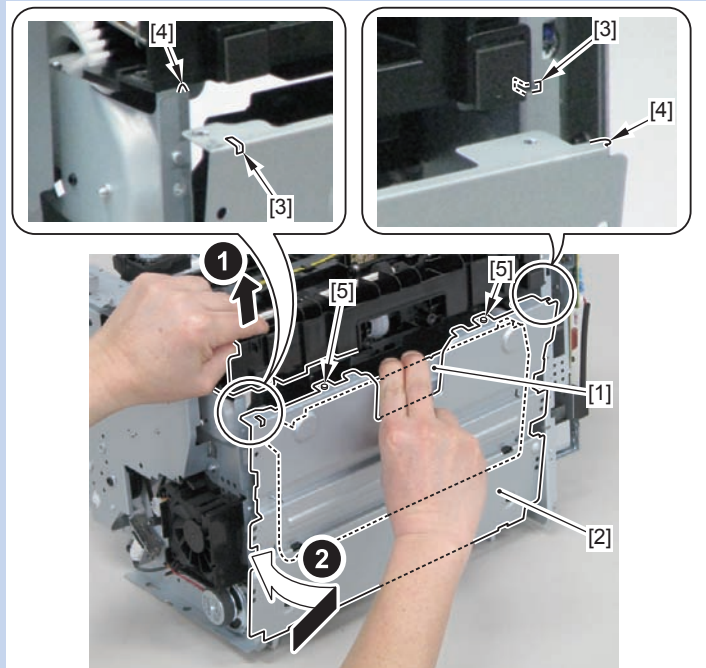

F-4-382

NOTE: How to assemble the Pickup Tray Unit

- 2) Fix the 6 screws [6] in the following order.
- 3) Be sure to check the positioning of the 6 bosses [7] when installing the Pickup Tray Unit.

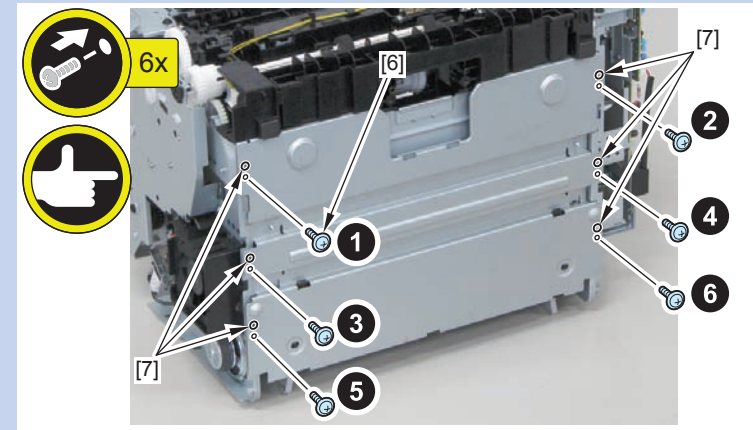

F-4-383

Removing the Pickup Roller (Duplex Model)



F-4-384

Procedure

CAUTION:

- Do not touch the surface of the Pickup Roller.
- Do not touch the Transfer Roller [1].

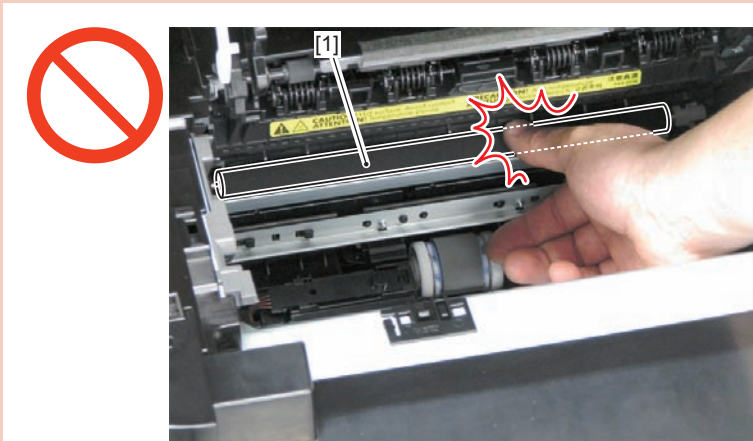

F-4-385

- 1-1) Open the DADF Unit + Reader Unit [1] and Delivery Tray [2] (DADF Model).
- 1-2) Open the SADF Unit + Reader Unit [1] and Delivery Tray [2] (SADF Model).
- 1-3) Open the Copyboard Cover + Reader Unit [1] and Delivery Tray [2] (Copyboard Model).
- 2) Remove the Pickup Roller [3].
 - 2 Claws [4]

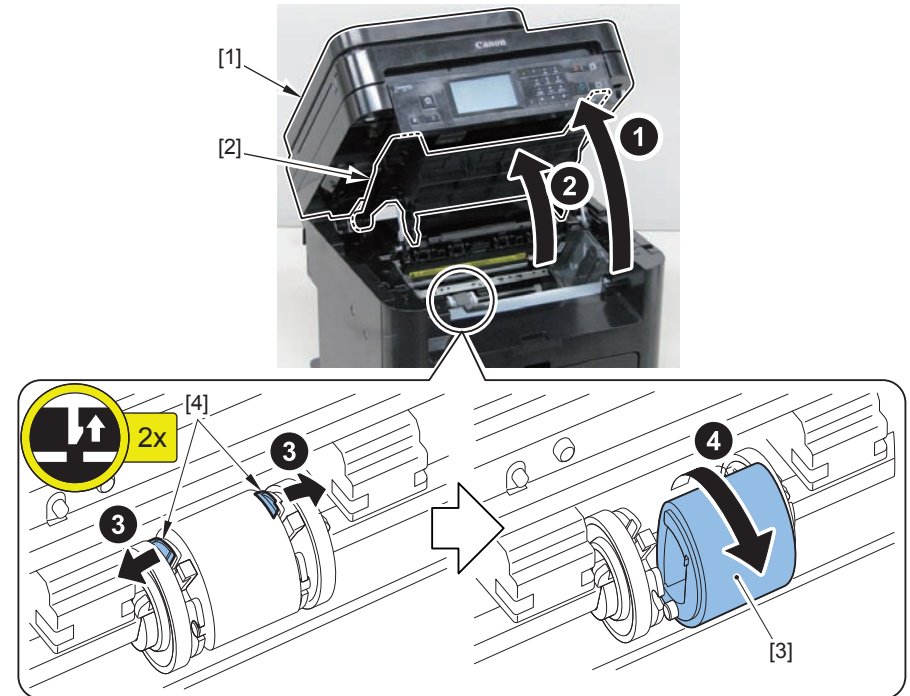

F-4-386

Removing the Separation Pad (Duplex Model)



F-4-387

Procedure

CAUTION:

Do not touch the surface of the Separation Pad.

- 1) Turn the machine so that it is placed with its left side down.
- 2-1) Hold and open the DADF Unit + Reader Unit [1] (DADF Model).
- 2-2) Hold and open the SADF Unit + Reader Unit [1] (SADF Model).
- 2-3) Hold and open the Copyboard Unit + Reader Unit [1] (Copyboard Model).

CAUTION:

Turning the machine sideways may release the tension of the hinge of the SADF Unit [2] and cause the units to open suddenly.

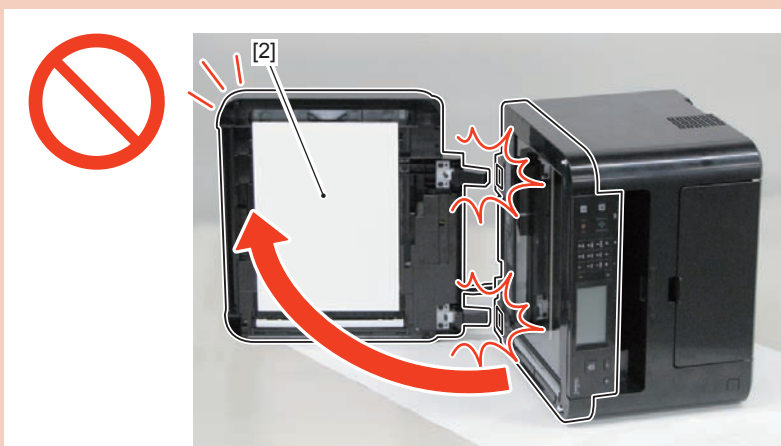

F-4-388

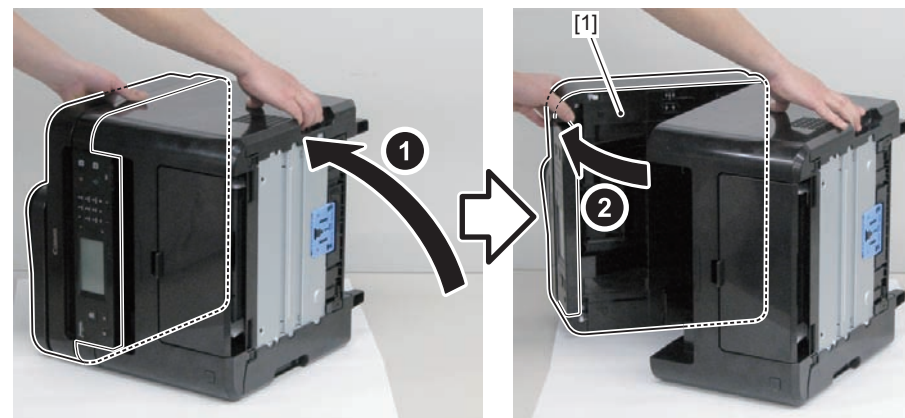

F-4-389

3) Remove the Separation Pad [1].

- 2 Screws [2]
- 2 Hooks [3]

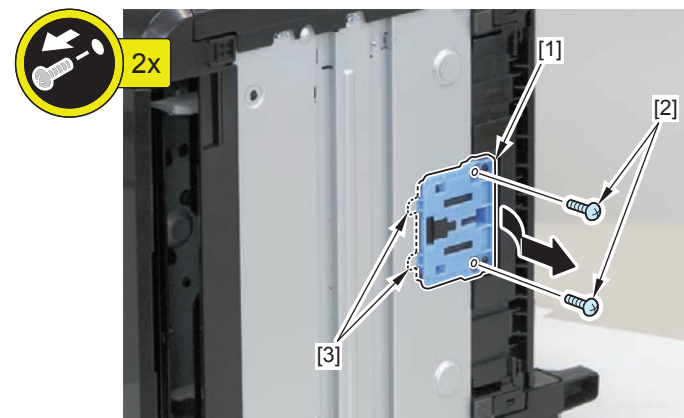

F-4-390

Removing the Delivery Slave Roller Unit (Duplex Model)



F-4-391

Procedure

- 1-1) Open the DADF Unit + Reader Unit [1] and Delivery Tray [2] (DADF Model).
- 1-2) Open the SADF Unit + Reader Unit [1] and Delivery Tray [2] (SADF Model).
- 1-3) Open the Copyboard Cover + Reader Unit [1] and Delivery Tray [2] (Copyboard Model).

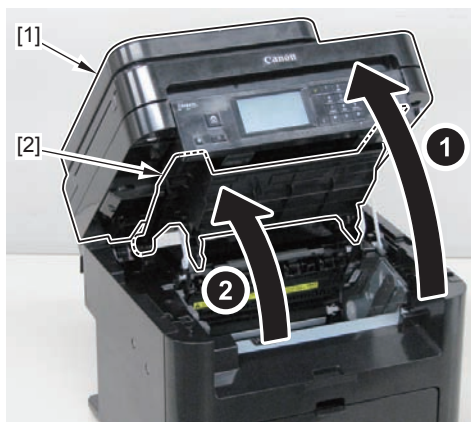

F-4-392

- 2) Remove the Delivery Slave Roller Unit [1].

- 2 Shafts [2]

CAUTION:

Do not damage the Delivery Slave Roller Unit [1] by bending it too much.

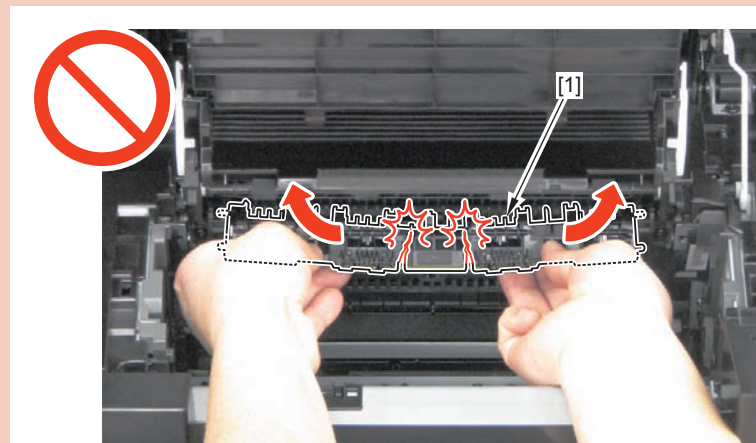

F-4-393

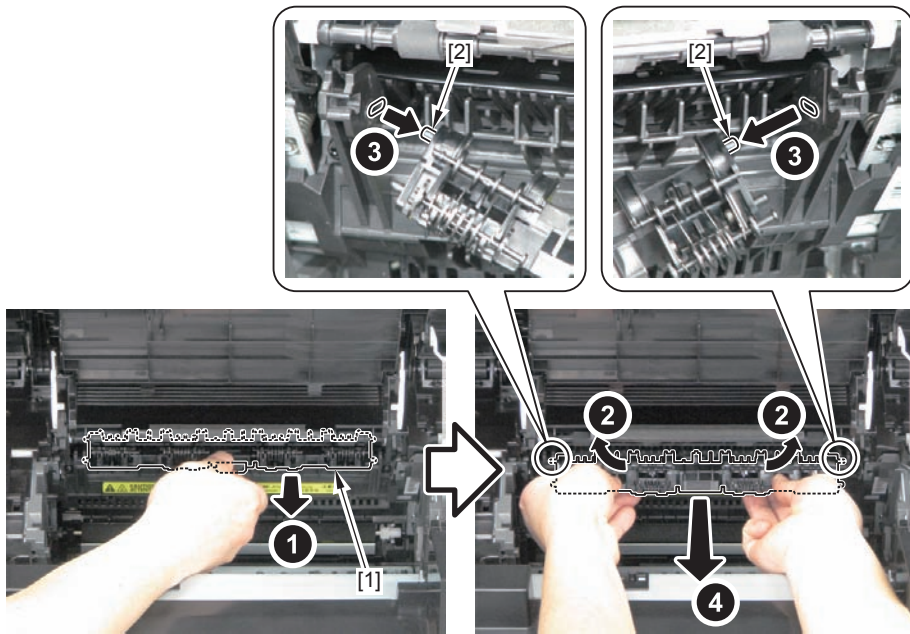

F-4-394

Removing the Pickup Solenoid (Duplex Model)



F-4-395

Preparation

- 1) Remove the Left Cover (Duplex Model) (Refer to page 4-86).
- 2-1) Remove the DADF Unit + Reader Unit (DADF Model) (Refer to page 4-27).
- 2-2) Remove the SADF Unit + Reader Unit (SADF Model) (Refer to page 4-51).
- 2-3) Remove the Copyboard Cover + Reader Unit (Copyboard Model) (Refer to page 4-76).
- 3) Remove the Right Cover (Duplex Model) (Refer to page 4-87).
- 4) Remove the Front Cover Unit (Duplex Model) (Refer to page 4-89).
- 5) Remove the Upper Cover Unit (Duplex Model) (Refer to page 4-89).
- 6) Remove the Duplex Feed Guide Unit (Duplex Model) (Refer to page 4-91).
- 7) Remove the Main Controller PCB (Duplex Model) (Refer to page 4-95).
- 8) Remove the FAX NCU PCB (FAX Model 120/230V) (Duplex Model) (Refer to page 4-107).
- 9) Remove the Edge Left Cooling Fan (Duplex Model) (Refer to page 4-99).

Procedure

1) Remove the Wireless LAN Unit [1] (Wifi Model).

- 1 Screw (black TP) [2]
- 2 Hooks [3]

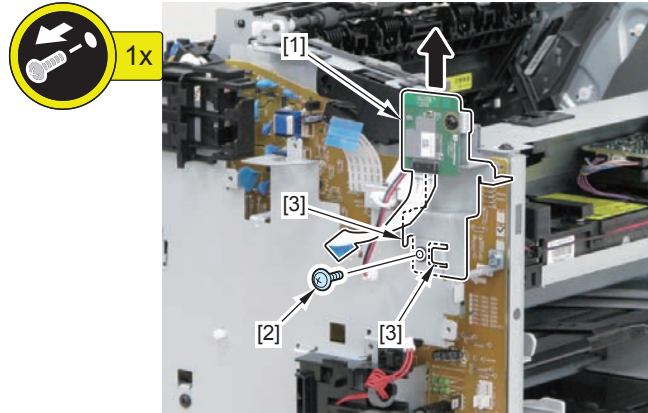

F-4-396

2) Remove the Main Controller PCB Installation Plate [1].

- 1 Relay Connector [2]
- Harness Guide [A]
- 1 Wire Saddle [3]
- 4 Screws (with washer) [4]
- 2 Screws (black TP) [5]

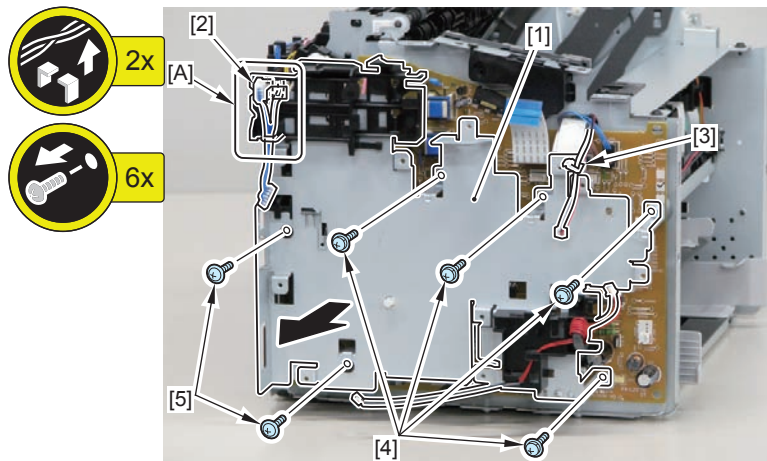

F-4-397

NOTE:

The Front Fixing Reinforcing Plate [1] should be removed before removing the Edge Left Cooling Fan Holder.

- 2 Screws (black TP) [2]

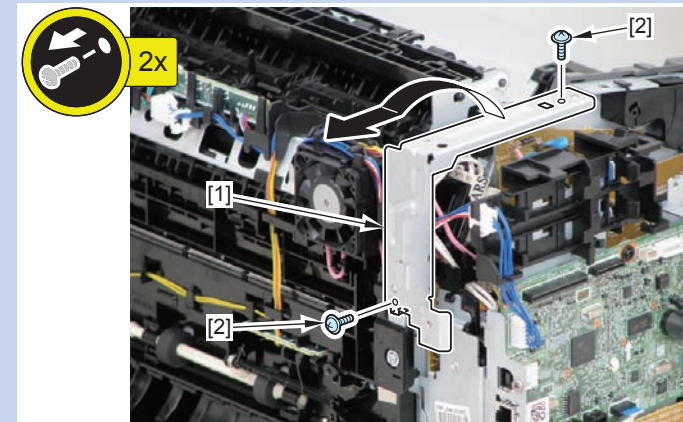

F-4-398

3) Free the harness [1] from the Harness Guide [A].

4) Remove the Edge Left Cooling Fan Holder [2].

- 1 Screw [3]

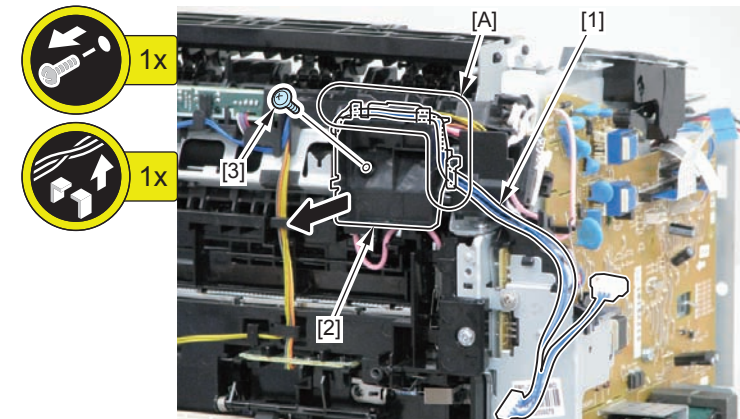

F-4-399

5) Free the harness [1] from the Harness Guide [A].

- 1 Terminal [2]

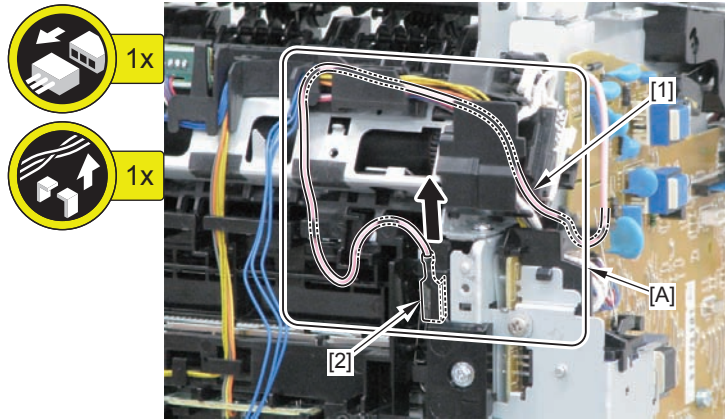

F-4-400

CAUTION:

Be sure that the terminal [2] is in contact with the Contact Spring [3].

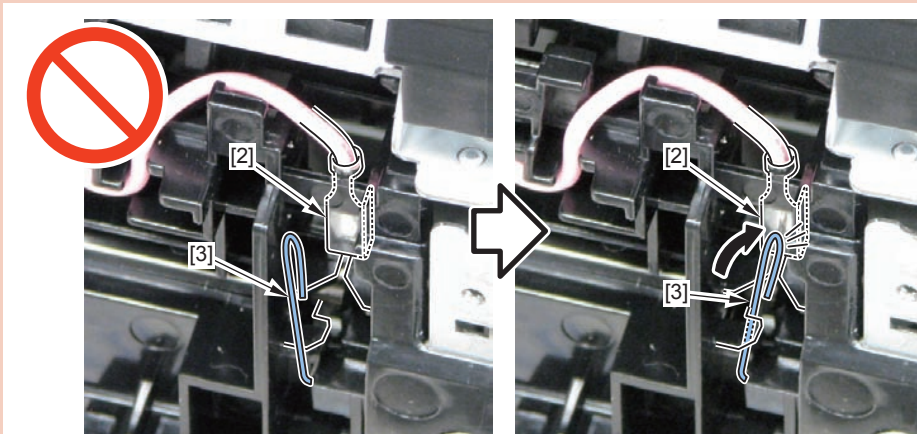

F-4-401

6) Remove the Harness Retaining Spring [1] from the 2 hooks [2].

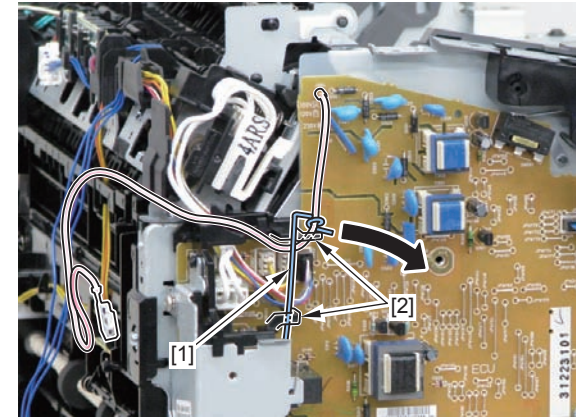

F-4-402

7) Disconnect the 4 connectors [1].

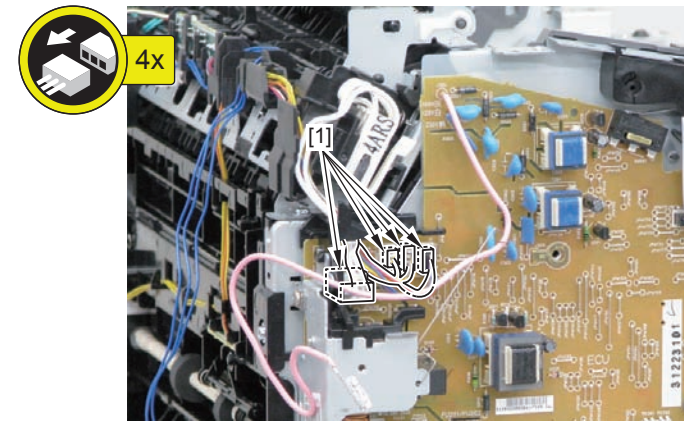

F-4-403

8) Free the Pickup Solenoid Harness [1] from the Harness Guide [A].

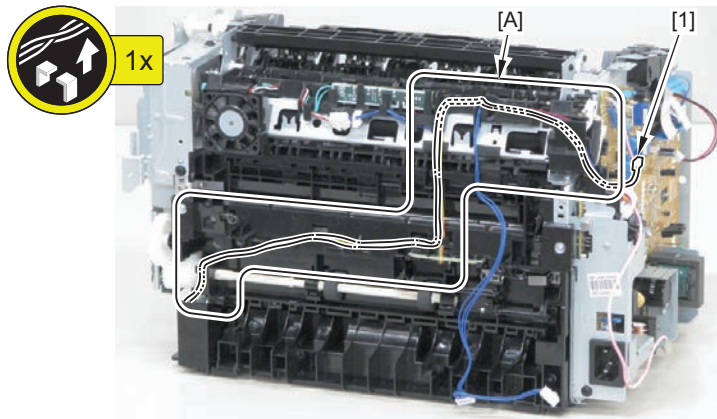

F-4-404

9) Move the Solenoid Arm [1] and remove the Pickup Solenoid [2].

- 1 Screw [3]

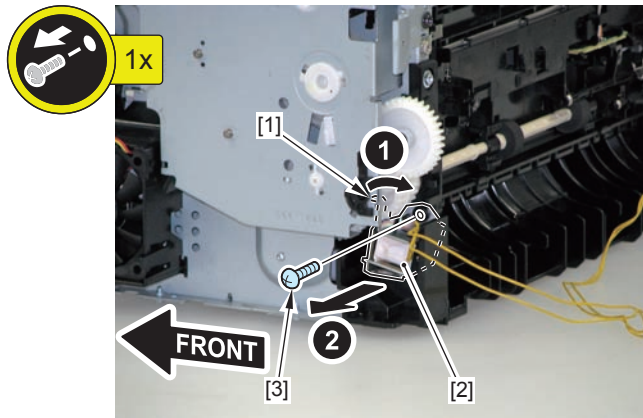

F-4-405

NOTE:

The following shows how to route the harness.

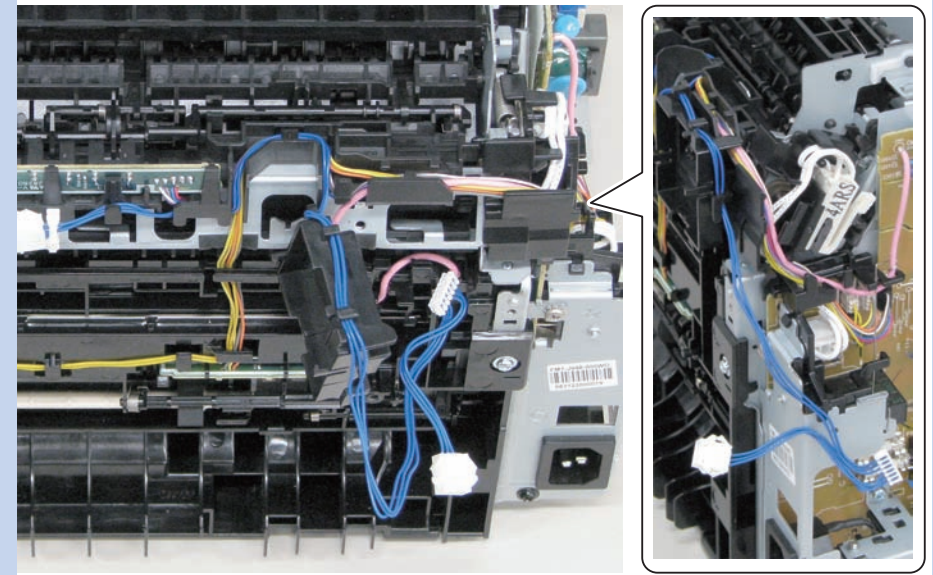

F-4-406

Removing the Duplex Solenoid (Duplex Model)



F-4-407

Preparation

- 1) Remove the Left Cover (Duplex Model) (Refer to page 4-86).
- 2-1) Remove the DADF Unit + Reader Unit (DADF Model) (Refer to page 4-27).
- 2-2) Remove the SADF Unit + Reader Unit (SADF Model) (Refer to page 4-51).
- 2-3) Remove the Copyboard Cover + Reader Unit (Copyboard Model) (Refer to page 4-76).
- 3) Remove the Right Cover (Duplex Model) (Refer to page 4-87).
- 4) Remove the Front Cover Unit (Duplex Model) (Refer to page 4-89).
- 5) Remove the Upper Cover Unit (Duplex Model) (Refer to page 4-89).

Procedure

- 1) Remove the Scanner Cover [1].
 - 2 Screws (black TP) [2]

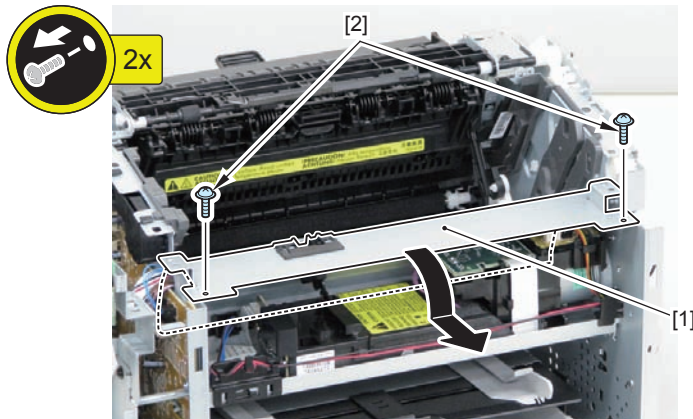

F-4-408

NOTE: How to assemble the Scanner Cover

- 1) Be sure to pass the Shutter Open/Close Lever [3] through the hole [A] of the Scanner Cover.

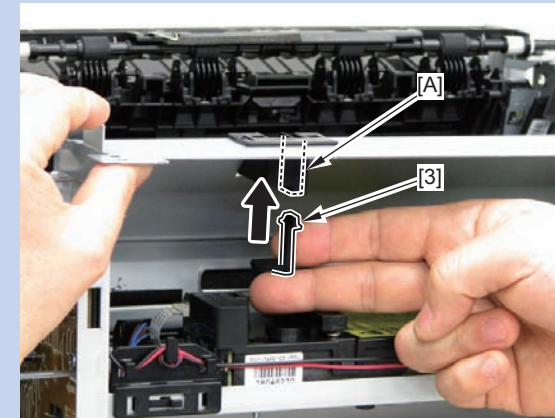

F-4-409

- 2) Be sure that the Shutter Open/Close Lever [3] can move vertically.

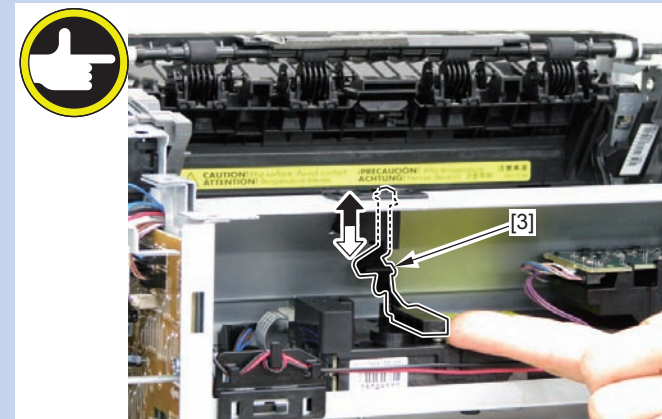

F-4-410

2) Free the Solenoid Harness [1] from the guide [A], and pass it through the hole [B] of the Right Plate to the outside.

- 1 Connector [2]

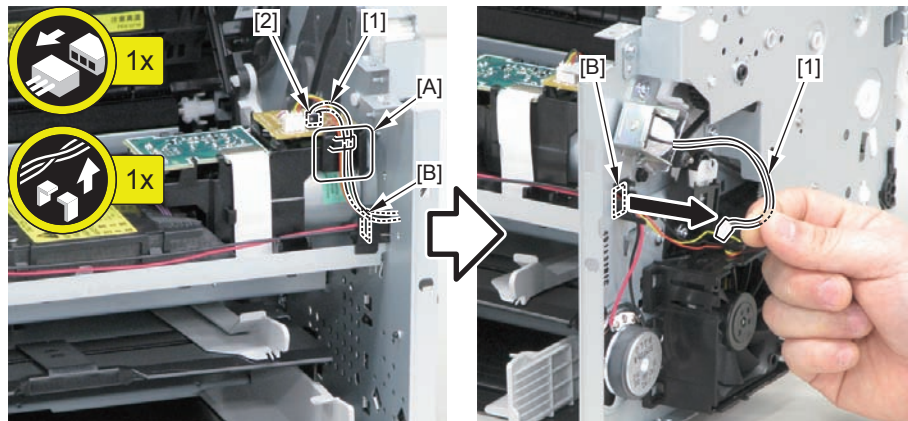

F-4-411

3) Remove the Duplex Solenoid [1].

- 1 Screw [2]

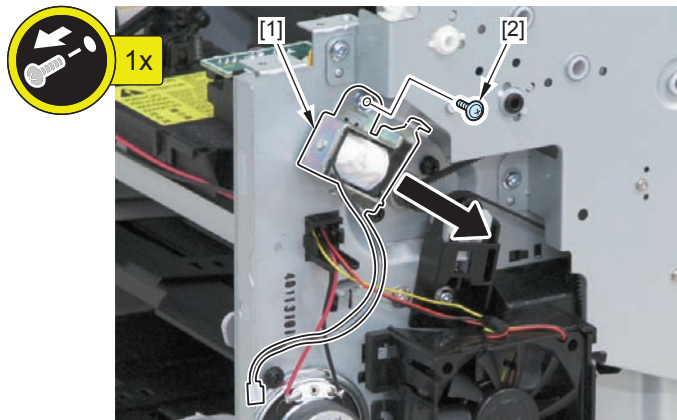

F-4-412

NOTE: How to assemble the Duplex Solenoid

Be sure to align the Solenoid Lever [1] with the groove [2] of the link, and fit the 2 Solenoid Positioning Bosses [3] in the 2 positioning holes [4] of the Side Plate.

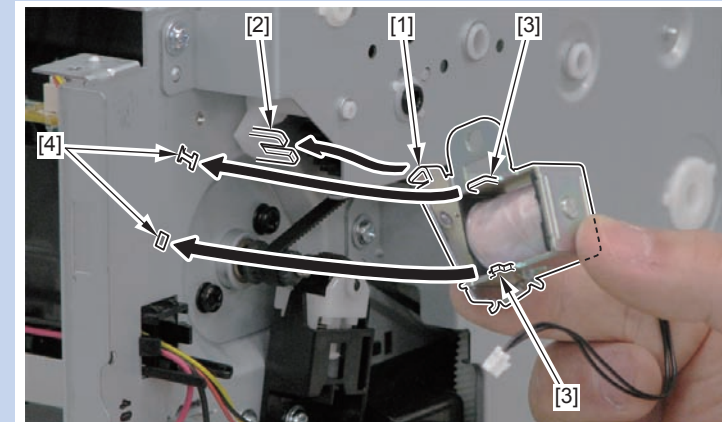

F-4-413

External Cover/Internal System (Simplex Model)

● Rear Side

● Layout Drawing

● Front Side

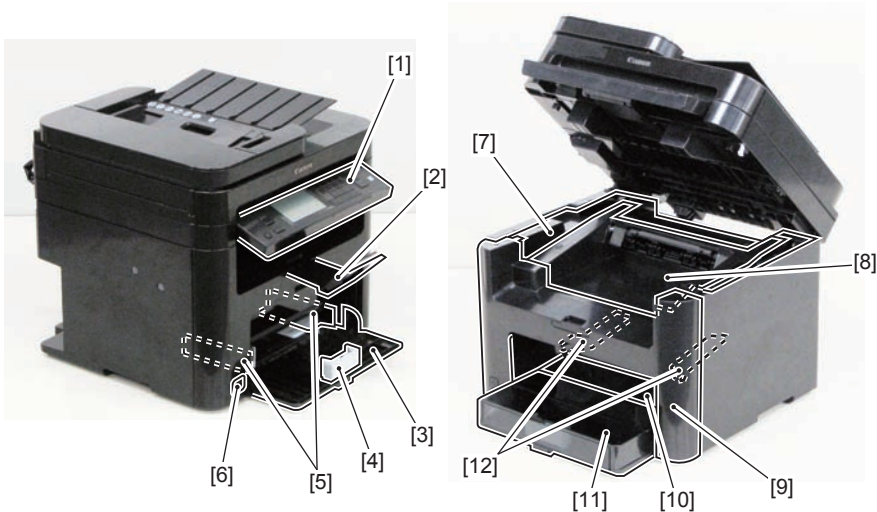

F-4-414

No.	Name	Reference	Remarks
[1]	Control Panel Unit	(Refer to page 4-151)	-
[2]	Delivery Auxiliary Tray		-
[3]	Pickup Tray		-
[4]	Trailing Edge Paper Guides		-
[5]	Pickup Tray Side Guide Plate		-
[6]	Power Switch		-
[7]	Upper Cover	(Refer to page 4-147)	-
[8]	Delivery Tray	(Refer to page 4-147)	-
[9]	Front Cover Unit	(Refer to page 4-147)	-
[10]	Multi-Purpose Tray		-
[11]	Tray Cover		-
[12]	Multi-Purpose Tray Side Guide Plate		-

T-4-46

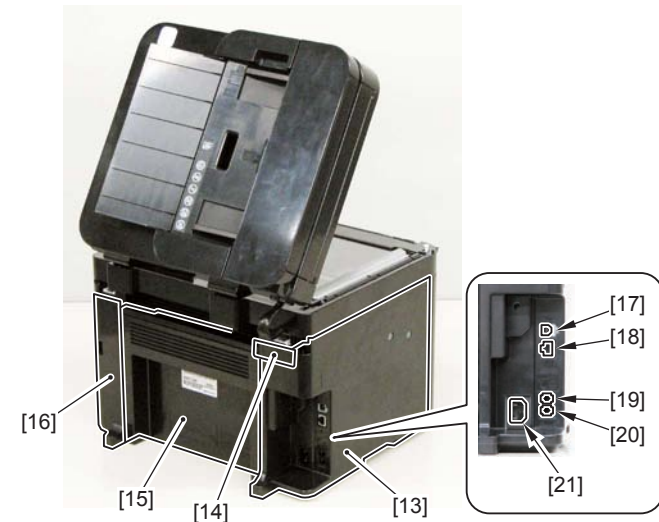

F-4-415

No.	Name	Reference	Remarks
[13]	Left Cover	(Refer to page 4-144)	-
[14]	Hinge Face Cover		-
[15]	Rear Cover	(Refer to page 4-149)	-
[16]	Right Cover	(Refer to page 4-145)	-
[17]	USB Device Port		-
[18]	LAN Port		Model with NET
[19]	External Device Jack		Model with FAX
[20]	Telephone Line Jack		Model with FAX
[21]	Power Supply Cord Slot		-

T-4-47

Removing the Left Cover (Simplex Model)

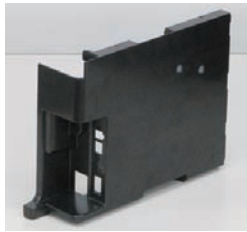

F-4-416

Procedure

NOTE:

The following shows the 5 claws [1] and 3 hooks [2] of the Left Cover.

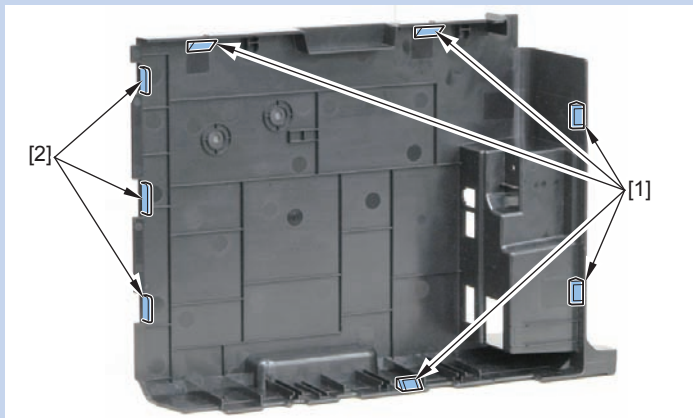

F-4-417

1) Remove the screw (black TP) [1].

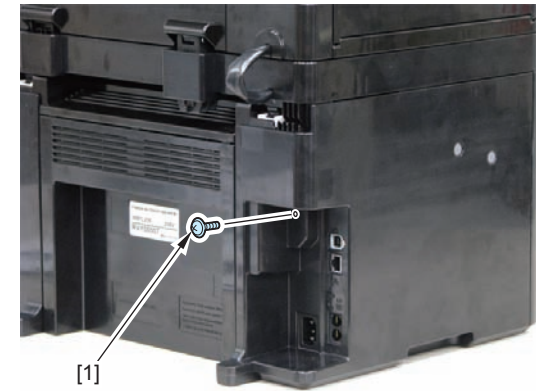

F-4-418

2) Release the 2 claws [1] at the rear side and the claw [2] at the lower side.

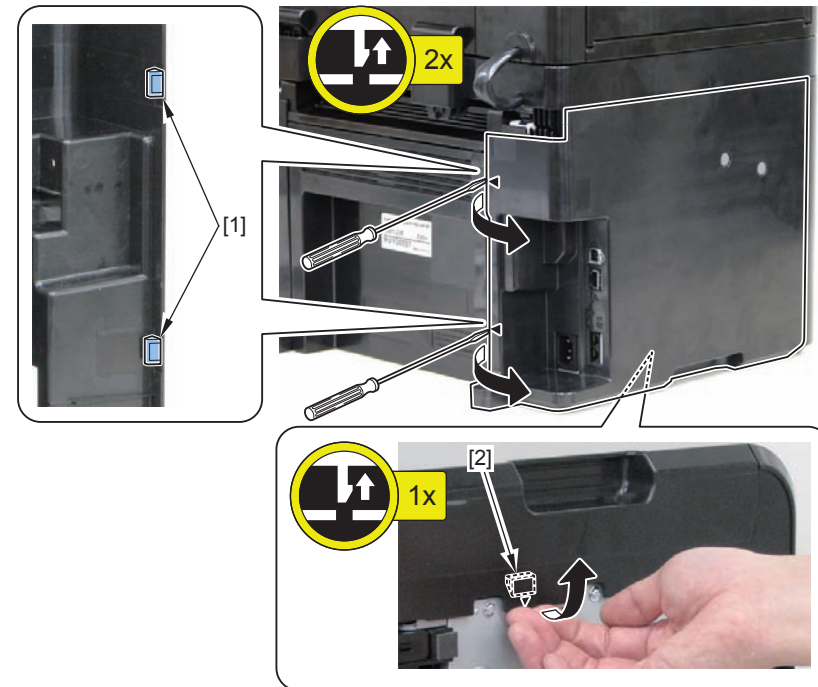

F-4-419

3-1) Open the SADF Unit + Reader Unit [1] (SADF Model).

3-2) Open the Copyboard Cover + Reader Unit [1] (Copyboard Model).



F-4-420

4) Release the 2 claws [1] at the upper side and remove the Left Cover [3] while releasing the 3 hooks [2].

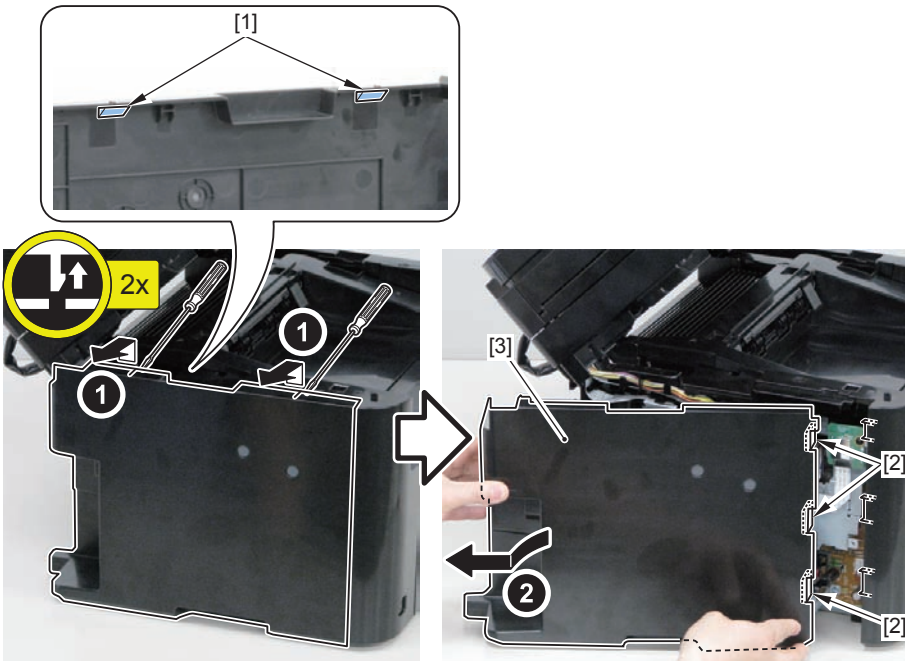

F-4-421

Removing the Right Cover (Simplex Model)



F-4-422

Procedure

NOTE:

The following shows the 5 claws [1] and 3 hooks [2] of the Right Cover.

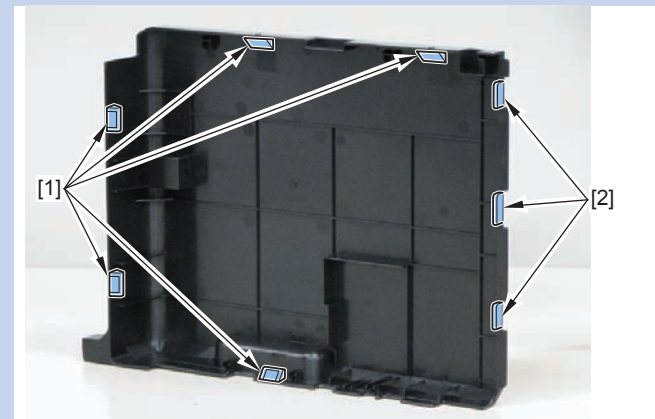

F-4-423

1) Remove the screw (black TP) [1].

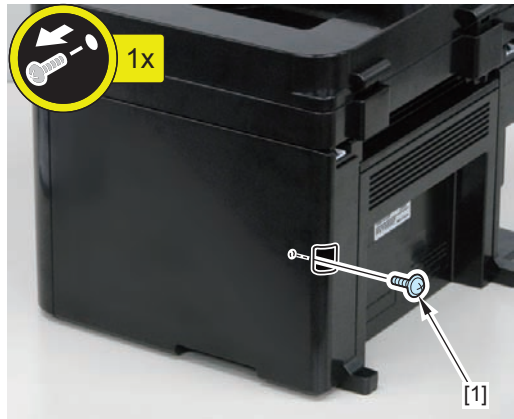

F-4-424

2) Release the 2 claws [1] at the rear side and the claw [2] at the lower side.

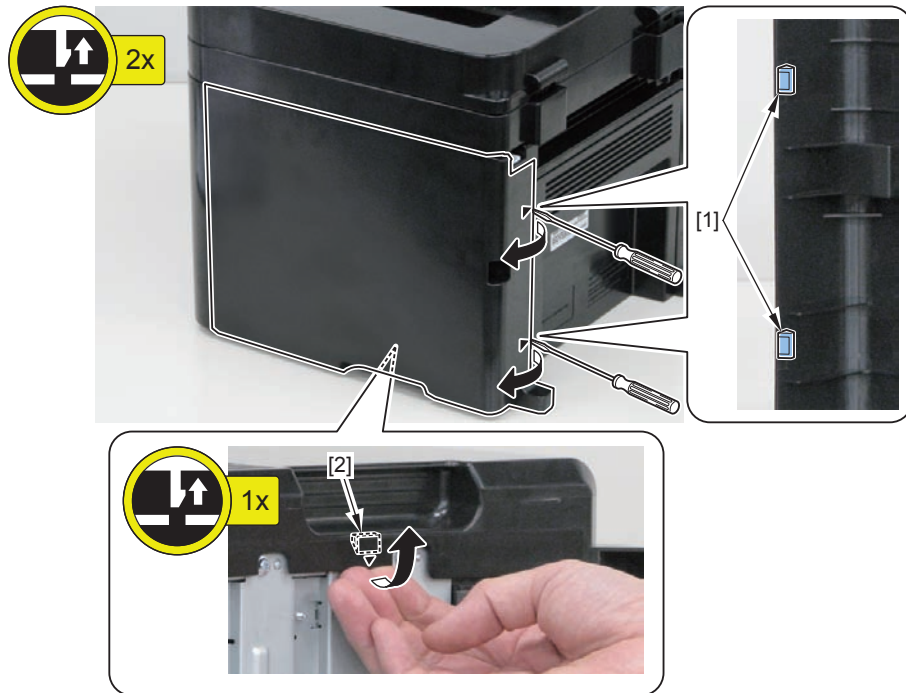

F-4-425

3-1) Open the SADF Unit + Reader Unit [1] (SADF Model).

3-2) Open the Copyboard Cover + Reader Unit [1] (Copyboard Model).



F-4-426

4) Release the 2 claws [1] at the upper side and remove the Left Cover [3] while releasing the 3 hooks [2].

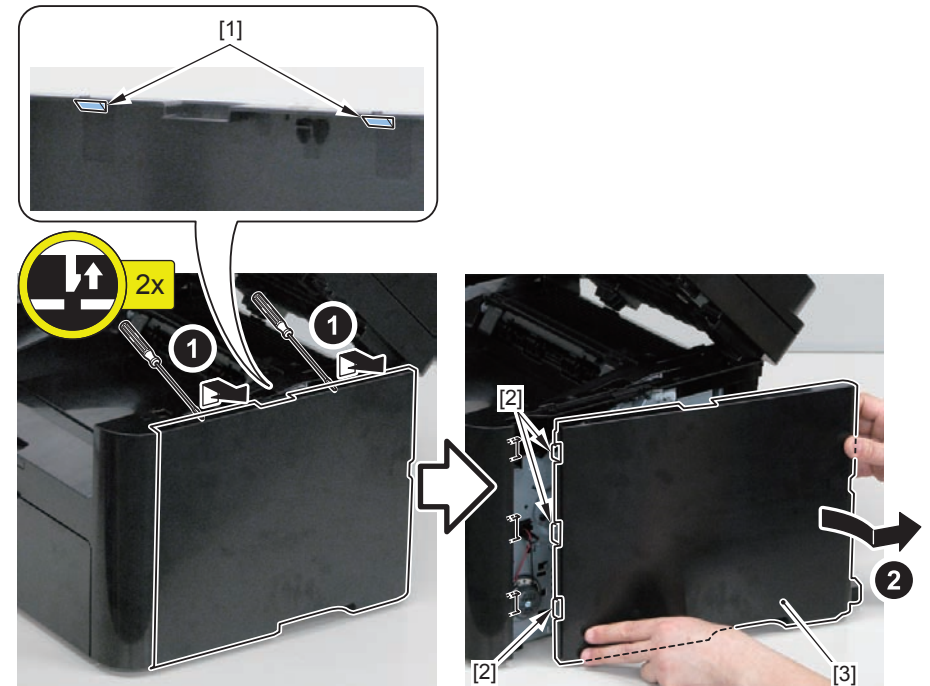

F-4-427

Removing the Front Cover Unit (Simplex Model)

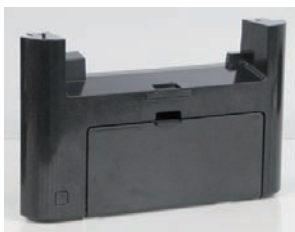

F-4-428

Preparation

- 1) Remove the Left Cover (Simplex Model) (Refer to page 4-144).
- 2) Remove the Right Cover (Simplex Model) (Refer to page 4-147).

Procedure

- 1) Remove the Front Cover Unit [1].

- 1 Connector [2]
- 2 Bosses [3]
- 2 Claws [4]

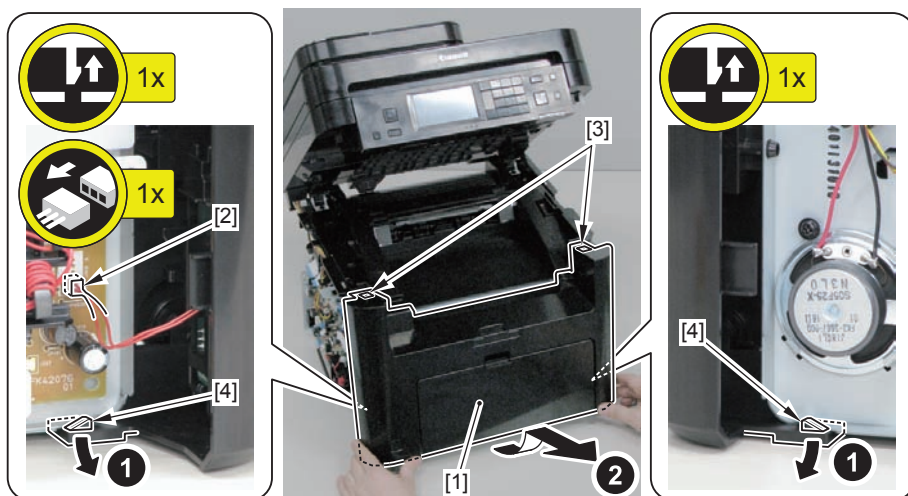

F-4-429

Removing the Upper Cover (Simplex Model)



F-4-430

Preparation

- 1) Remove the Left Cover (Simplex Model) (Refer to page 4-144).
- 2-1) Remove the SADF Unit + Reader Unit (SADF Model) (Refer to page 4-51).
- 2-2) Remove the Copyboard Cover + Reader Unit (Copyboard Model) (Refer to page 4-76).
- 3) Remove the Right Cover (Simplex Model) (Refer to page 4-147).
- 4) Remove the Front Cover Unit (Simplex Model) (Refer to page 4-147).

Procedure

- 1) Open the Delivery Tray [1].
- 2) Remove the Cartridge Arm [2].
- 3) Remove the 2 Fixing Pressure Arms [3].

CAUTION:

Be careful not to lose the Cartridge Arm [2] and the 2 Fixing Pressure Arms [3].

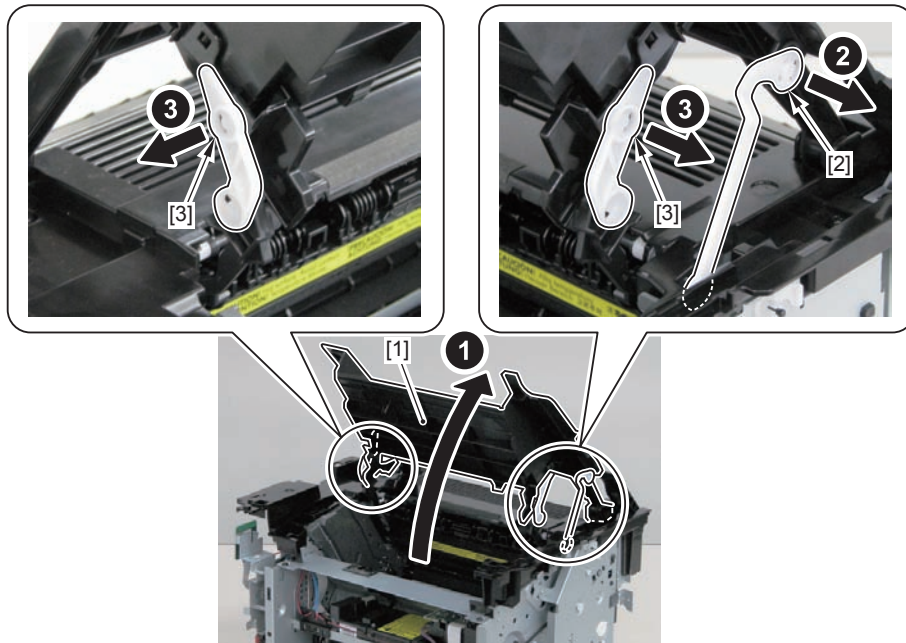

F-4-431

- 4) Remove the Delivery Tray [1].

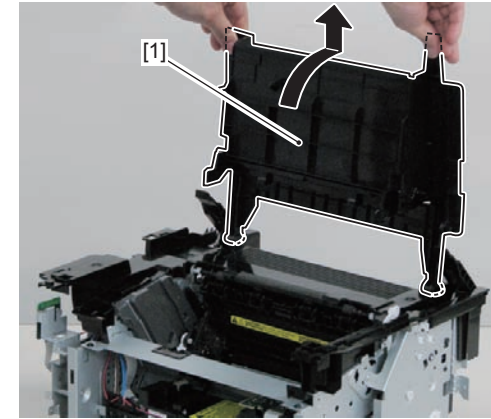

F-4-432

- 5) Remove the Upper Cover Unit [1].

- 4 Screws (black TP) [2]

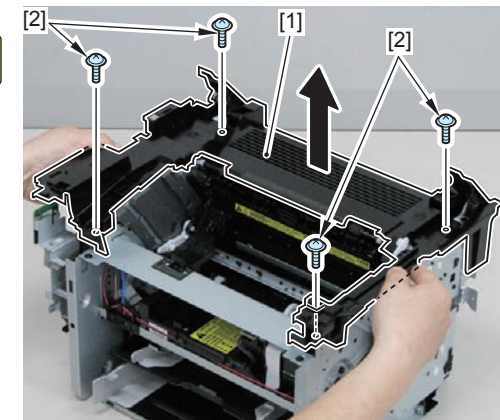

F-4-433

NOTE: How to assemble the Delivery Tray

- 1) Pass the Cartridge Arm [1] through the hole [A] of the Upper Cover Unit.
- 2) Install the Cartridge Arm [1] and the 2 Fixing Pressure Arms [2] on the Delivery Tray [3].

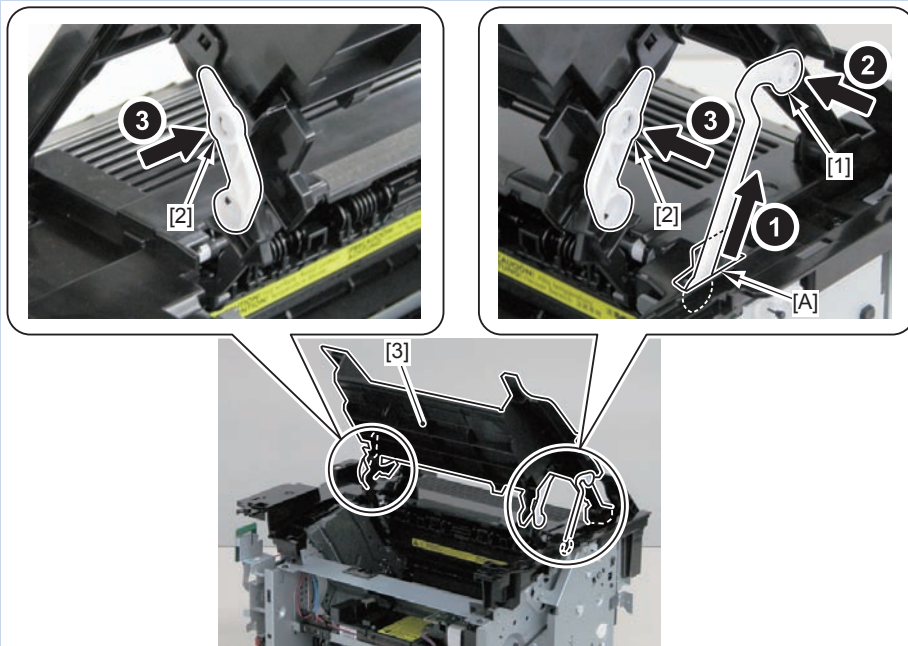

F-4-434

Removing the Rear Cover (Simplex Model)



F-4-435

Preparation

- 1) Remove the Left Cover (Simplex Model) (Refer to page 4-144).
- 2-1) Remove the SADF Unit + Reader Unit (SADF Model) (Refer to page 4-51).
- 2-2) Remove the Copyboard Cover + Reader Unit (Copyboard Model) (Refer to page 4-76).
- 3) Remove the Right Cover (Simplex Model) (Refer to page 4-147).
- 4) Remove the Front Cover Unit (Simplex Model) (Refer to page 4-147).
- 5) Remove the Upper Cover (Simplex Model) (Refer to page 4-147).

Procedure

- 1) Remove the 2 screws (black TP) [1].



2x

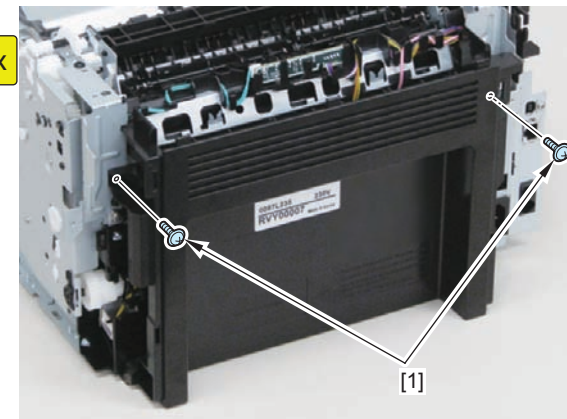

F-4-436

2) Remove the Rear Cover [1].

- 1 Claw [2]
- 2 Hooks [3]

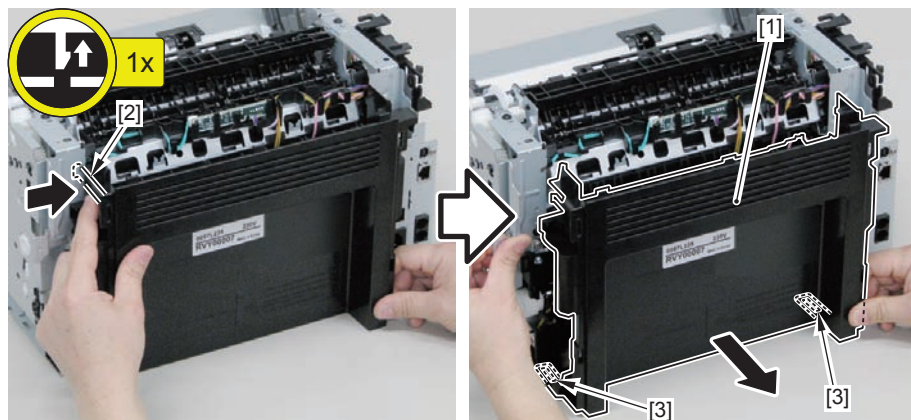

F-4-437

Controller System (Simplex Model)

Layout Drawing

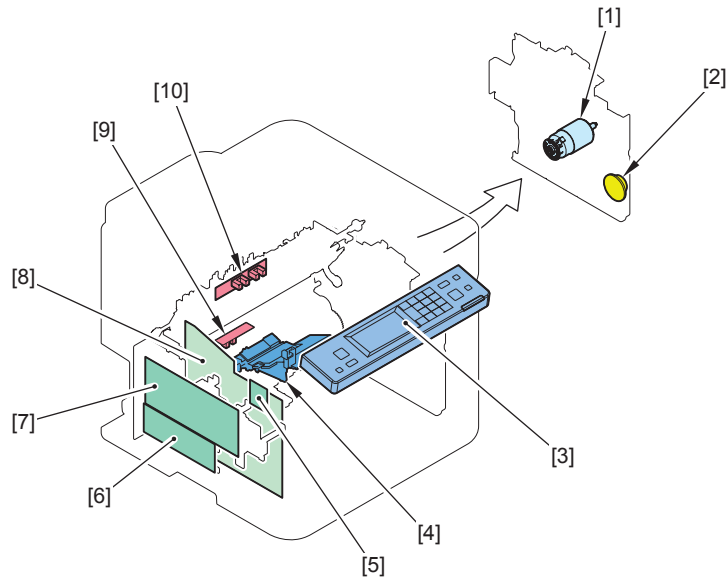

F-4-438

No.	Name	Reference	Remarks
[1]	Main Motor	(Refer to page 4-153)	
[2]	Speaker	(Refer to page 4-169)	Fax Model
[3]	Control Panel Unit	(Refer to page 4-151)	
[4]	Toner Sensor and Multi Pickup Sensor Unit	(Refer to page 4-167)	Fax Model
[5]	Wireless LAN PCB	(Refer to page 4-161)	Wifi Model
[6]	FAX NCU PCB	(Refer to page 4-161)	Fax Model 120V/230V
[7]	Main Controller PCB	(Refer to page 4-159)	
[8]	Engine Controller PCB	(Refer to page 4-155)	
[9]	Paper Leading Edge Sensor PCB	(Refer to page 4-162)	
[10]	Fixing Delivery/Paper Width Sensor PCB	(Refer to page 4-164)	

T-4-48

Removing the Control Panel Unit (Simplex Model)



F-4-439

Procedure

- 1-1) Open the SADF Unit + Reader Unit [1] (SADF Model).
- 1-2) Open the Copyboard Cover + Reader Unit [1] (Copyboard Model).
- 2) Lift the Control Panel Unit [2].

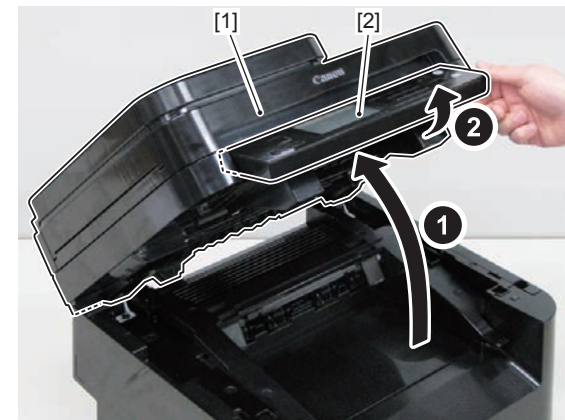

F-4-440

3) Remove the 4 Screws [1].

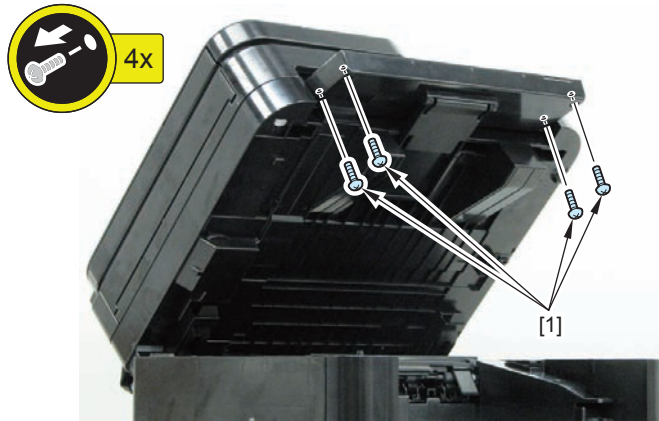

F-4-441

4-1) Close the Reader Unit [1], and open the SADF Unit [2] (SADF Model).

4-2) Close the Reader Unit [1], and open the Copyboard Unit 1 [2] (Copyboard Model).

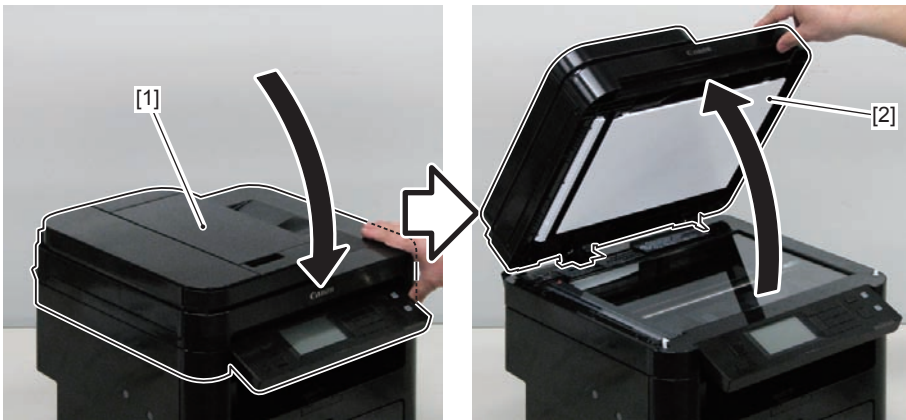

F-4-442

5) Remove the Control Panel Unit [1].

- 6 Claws [2]
- 1 Flat Cable [3]

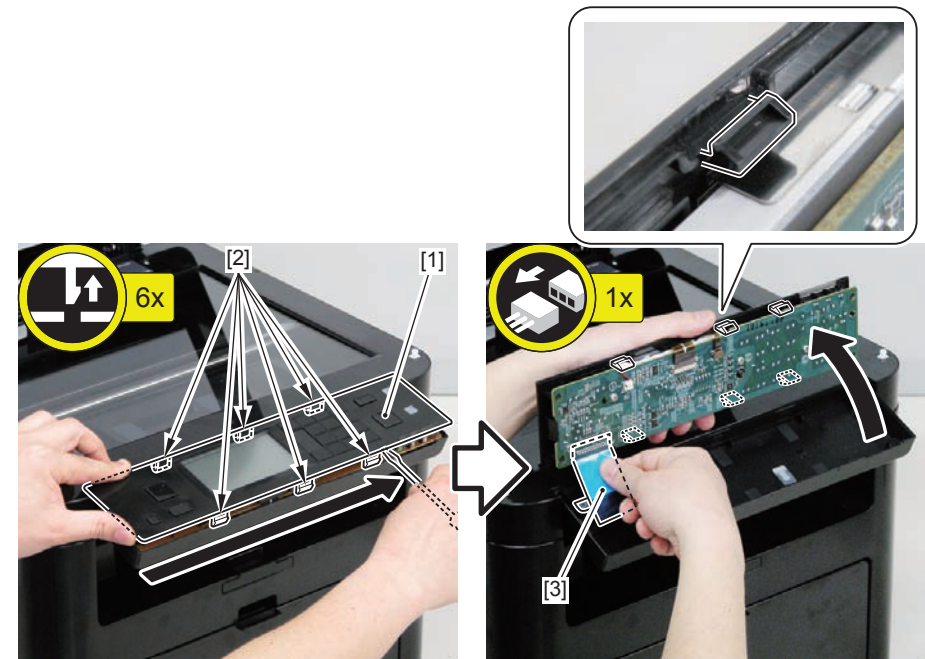

F-4-443

Removing the Main Motor (Simplex Model)



F-4-444

Preparation

- 1) Remove the Left Cover (Simplex Model) (Refer to page 4-144).
- 2-1) Remove the SADF Unit + Reader Unit (SADF Model) (Refer to page 4-51).
- 2-2) Remove the Copyboard Cover + Reader Unit (Copyboard Model) (Refer to page 4-76).
- 3) Remove the Right Cover (Simplex Model) (Refer to page 4-147).
- 4) Remove the Front Cover Unit (Simplex Model) (Refer to page 4-147).
- 5) Remove the Upper Cover (Simplex Model) (Refer to page 4-147).

Procedure

- 1) Remove the Scanner Cover [1].
 - 2 Screws (black TP) [2]

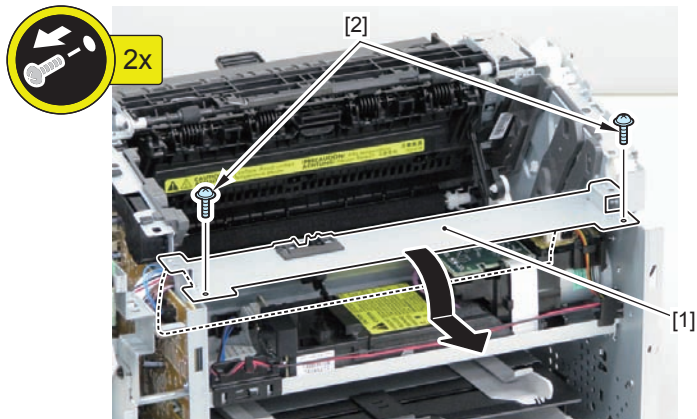

F-4-445

NOTE: How to assemble the Scanner Cover

- 1) Be sure to pass the Shutter Open/Close Lever [3] through the hole [A] of the Scanner Cover.

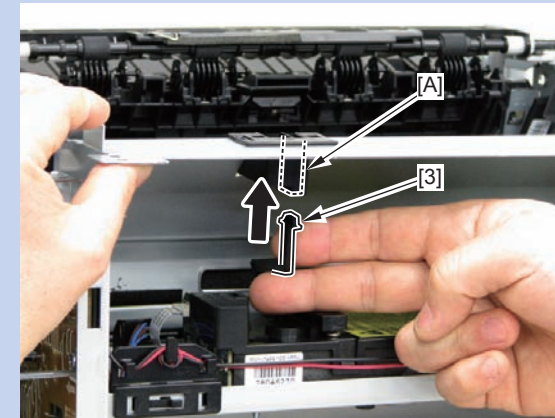

F-4-446

- 2) Be sure that the Shutter Open/Close Lever [3] can move vertically.

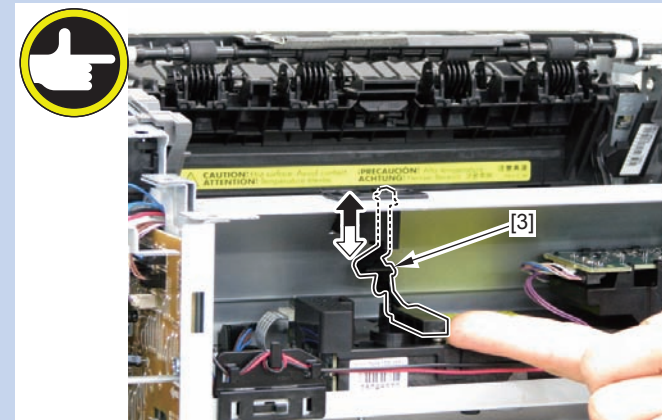

F-4-447

2) Remove the Motor Driver PCB [1].

- 2 Connectors [2]
- 2 Claws [3]
- 1 Hook [4]

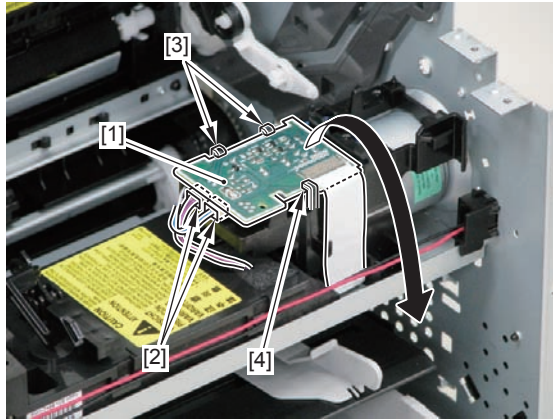
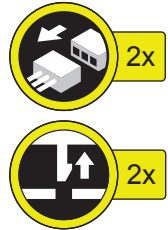

F-4-448

3) Free the Motor Harness [1] from the Harness Guide [A].

4) Remove the Motor Guide [2].

- 1 Screw [3]
- 1 Hook [4]

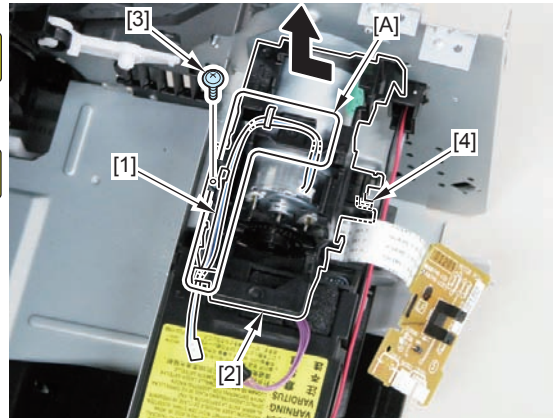

F-4-449

5) Remove the Tension Unit [1].

- 1 Screw [2]

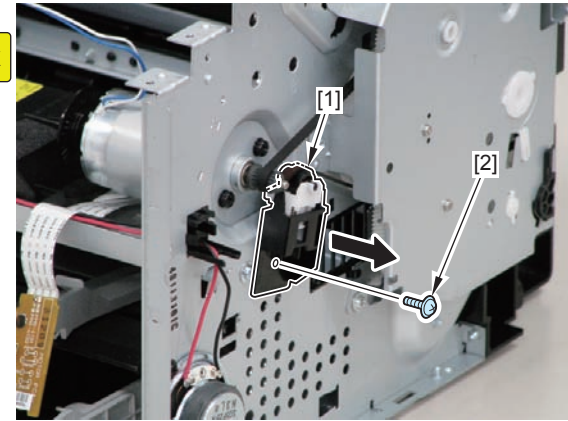

F-4-450

6) Remove the Main Motor [1].

- 2 Screws (with plain washer) [2]

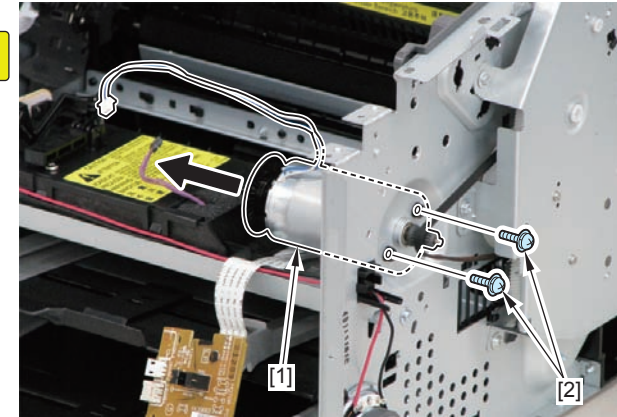

F-4-451

NOTE: How to assemble the Main Motor

Be sure to assemble it with the harness [1] routed upwards.

(Otherwise, the connector of the Speaker Harness cannot reach the Motor Driver PCB.)

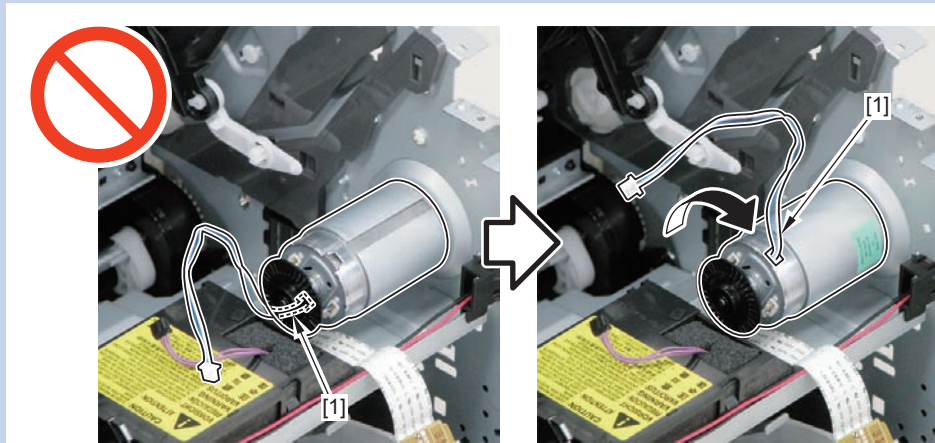

F-4-452

Removing the Engine Controller PCB (Simplex Model)

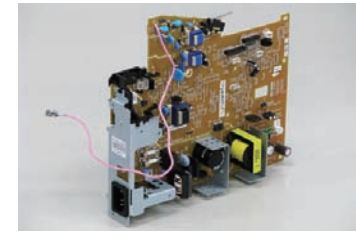

F-4-453

Preparation

- 1) Remove the Left Cover (Simplex Model) (Refer to page 4-144).
- 2-1) Remove the SADF Unit + Reader Unit (SADF Model) (Refer to page 4-51).
- 2-2) Remove the Copyboard Cover + Reader Unit (Copyboard Model) (Refer to page 4-76).
- 3) Remove the Right Cover (Simplex Model) (Refer to page 4-147).
- 4) Remove the Front Cover Unit (Simplex Model) (Refer to page 4-147).
- 5) Remove the Upper Cover (Simplex Model) (Refer to page 4-147).
- 6) Remove the Rear Cover (Simplex Model) (Refer to page 4-149).
- 7) Remove the Main Controller PCB (Simplex Model) (Refer to page 4-159).
- 8) Remove the FAX NCU PCB (FAX Model 120/230V) (Simplex Model) (Refer to page 4-161).

Procedure

1) Remove the Wireless LAN Unit [1] (Wifi Model).

- 1 Screw (black TP) [2]
- 2 Hooks [3]

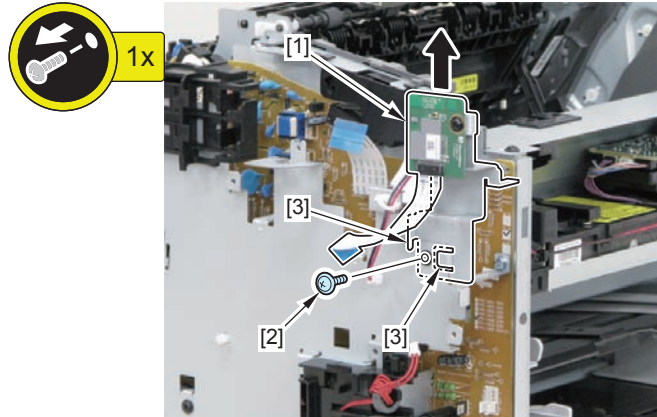

F-4-454

2) Remove the Main Controller PCB Installation Plate [1].

- 1 Wire Saddle [2]
- 4 Screws (with washer) [3]
- 2 Screws (black TP) [4]

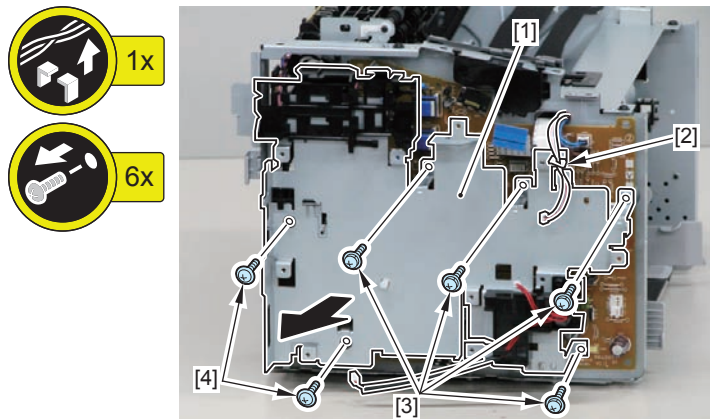

F-4-455

3) Free the harness [1] from the Harness Guide [A].

- 1 Terminal [2]

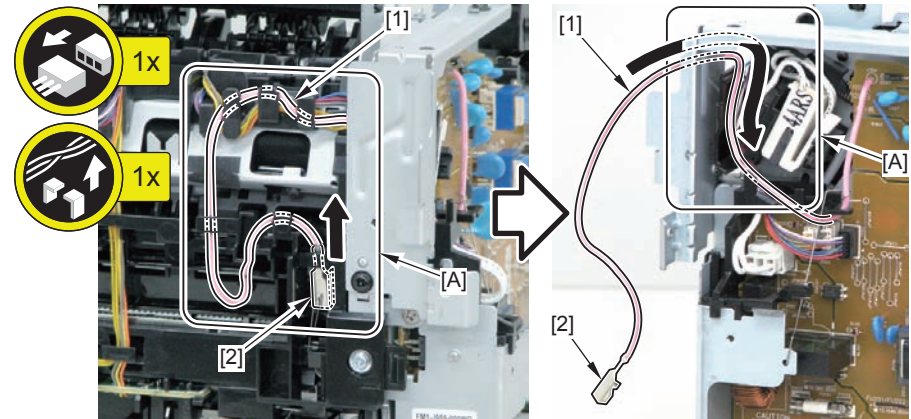

F-4-456

CAUTION:

Be sure that the terminal [2] is in contact with the Contact Spring [3].

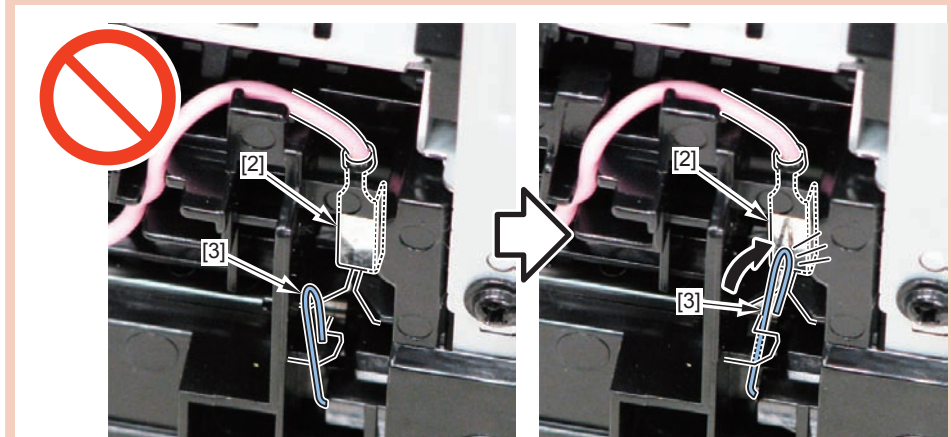

F-4-457

4) Remove the Harness Retaining Spring [1] from the 2 hooks [2].

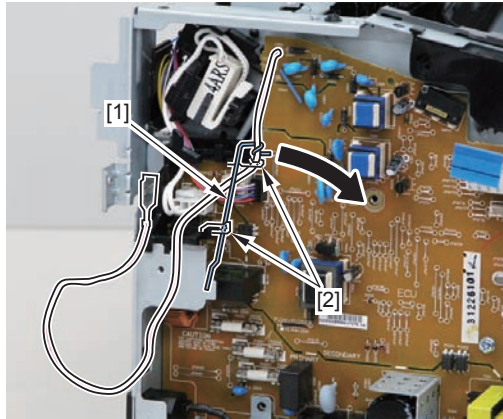

F-4-458

5) Remove the 3 Flat Cables [2], the 6 connectors [3], and the connector [4] (Fax Model) installed on the Engine Controller PCB [1].

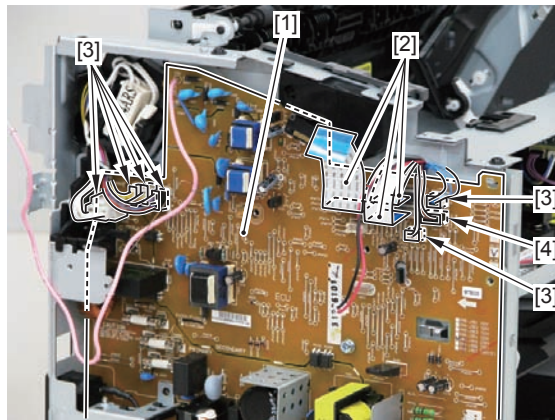

F-4-459

6) Free the harness [1] from the guide [A].

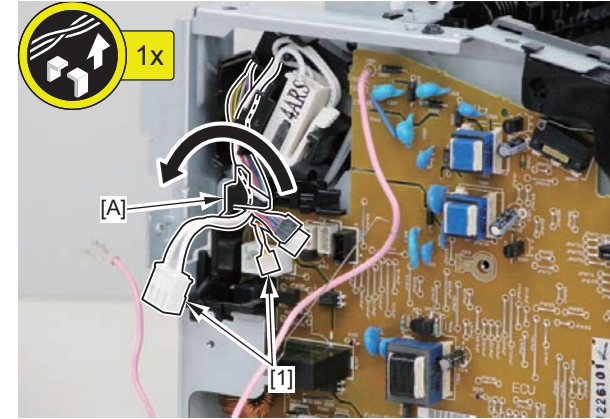

F-4-460

7) Remove the Engine Controller PCB [1].

- 2 Screws (with plain washer) [2]
- 1 Screw (with toothed lock washer) [3]
- 1 Screw (black TP) [4]
- 2 Hooks [5]

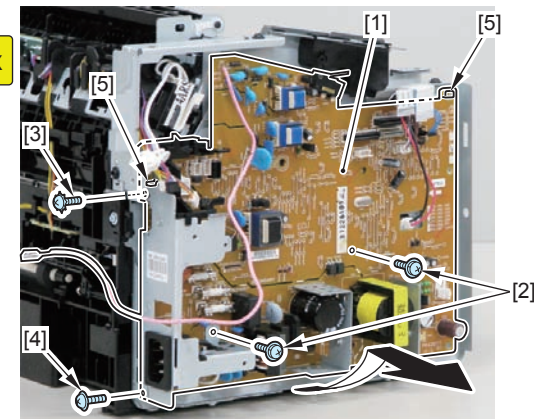

F-4-461

NOTE: How to assemble the Engine Controller PCB

- Put the Switchboard [2] in the lower part of the Switch Arm [1], and hook the Engine Controller PCB on the hook [3].

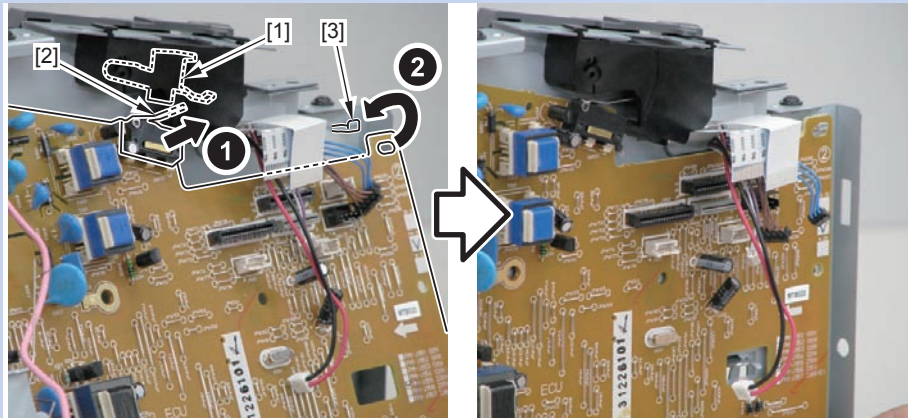

F-4-462

- Be sure that the Switch Arm [1] can move vertically.

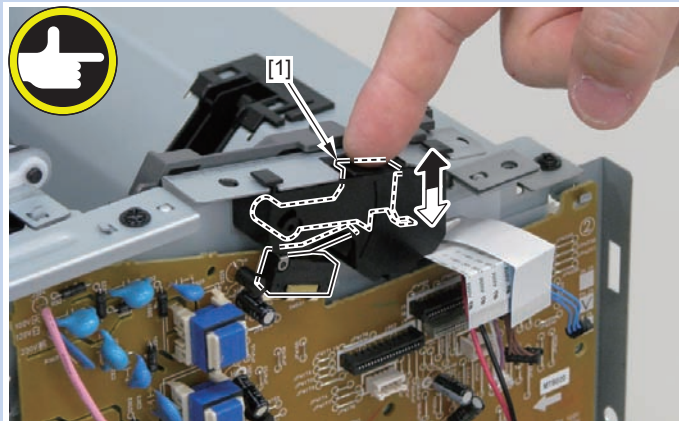

F-4-463

CAUTION:

Be careful not to install the Flat Cable [1] in the wrong direction.

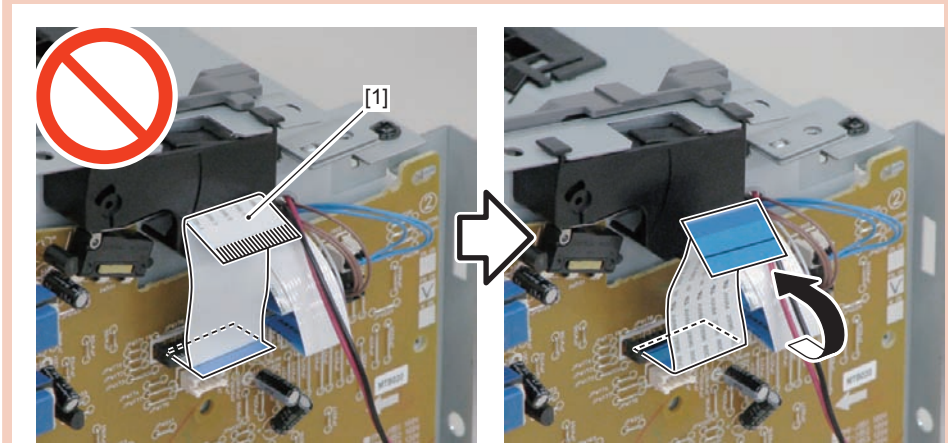

F-4-464

Removing the Main Controller PCB (Simplex Model)



F-4-465

Before Replacing

- 1) Before starting the replacement, output a status print.
After replacing the Main Controller, the serial number of the host machine needs to be written to the Main Controller.
- 2) Ask the user to perform the following operations if possible.
 - Ask the user to print the user data list.
[Menu] > [Output Report] > [Output Rprt.] > [User Data List]
 - Ask the user to save the address book from remote UI.
 1. Start remote UI and log in in administrator mode.
 2. Click [Settings/Registration] > [Import/Export] > [Export] > [Start Exporting].
 3. Follow the instructions on the screen to specify the location to save the address book.

Preparation

- 1) Remove the Left Cover (Simplex Model) (Refer to page 4-144).

Procedure

- 1) Disconnect all the Flat Cables [1] and connectors [2] installed on the Main Controller PCB.

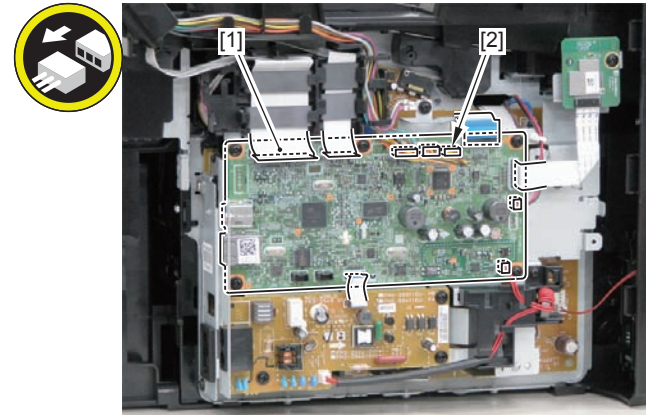

F-4-466

- 2) Remove the Main Controller PCB [1].

- 1 Screw [2]
- 5 Screws (black TP) [3]

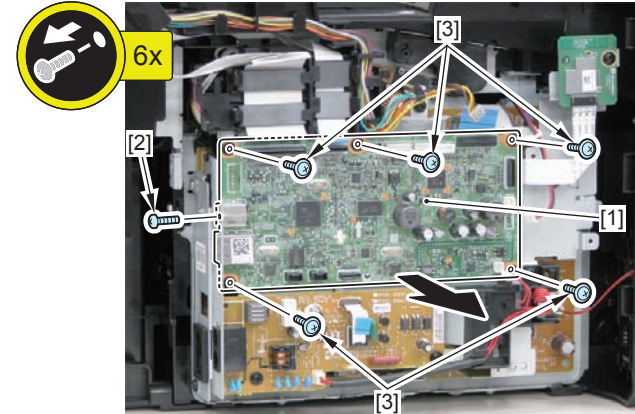

F-4-467

NOTE:

The layout of the connectors on the Main Controller PCB is shown below.

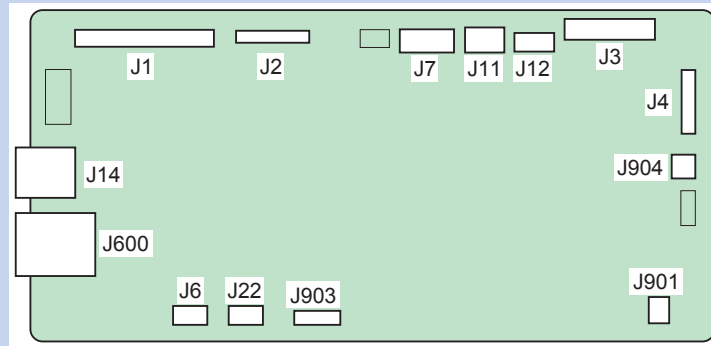

F-4-468

J No.	J No.	Symbol	Name	Remarks
J1	J401	UNIT14	Control Panel PCB	
J2	J1601	CIS	CIS Sensor	
J3	J902	UNIT2	Engine Controller PCB	
J4	J1	UNIT13	Wireless LAN PCB	Wifi Model
J6	-	-	-	
J7	J1406	PS4	Original Sensor	SADF Model
J7	J1407	PS5	Original Edge Sensor	SADF Model
J11	-	M3	Flatbed Motor Unit	
J12	J1401	M5	SADF Motor Unit	SADF Model
J14	-	-	USB	
J22	-	-	-	
J600	-	-	LAN	
J901	J1204	UNIT16	FAX NCU PCB	FAX Model
J903	J1201	UNIT16	FAX NCU PCB	FAX Model
J904	-	SP1	Speaker	FAX Model

T-4-49

After Replacing

- After replacing the PCB, enter the serial number in "Location " of System Management Settings from remote UI or local UI, and confirm the serial number.
- Check that OK is displayed in COPIER > OPTION > SERIAL > SN-MAIN.
 - For the detailed procedure, refer to the chapter on service mode.
- COPIER > OPTION > BODY > LOCALE
To set country group.
 - Japan
 - North America
 - Korea
 - China
 - Taiwan
 - Europe
 - Asia
 - Oceania
 Setting range: 1 - 8 (Service part default value: 2)
- Execute the following service mode to enable this setting.
COPIER > FUNCTION > CLEAR > ALL
- If the user has printed the user data list and saved the address book before the replacement, ask the user to return the settings back to the original values.
 - Ask the user to load the address book from remote UI.
 - Start remote UI and log in in administrator mode.
 - [Settings/Registration] > [Import/Export] > [Import]
 - Select the address book file to be imported, and click [Start Importing].
 - Click [OK].

Removing the FAX NCU PCB (Fax Model 120V/230V + Simplex Model)



F-4-469

Preparation

1) Remove the Left Cover (Simplex Model) (Refer to page 4-144).

Procedure

1) Remove the FAX NCU PCB [1].

- 1 Flat Cable [2]
- 1 Connector [3]
- 3 Screws [4]

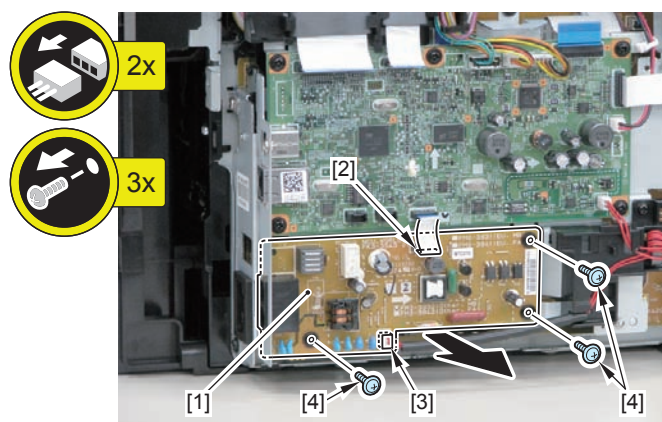

F-4-470

Removing the Wireless LAN PCB (Wifi Model + Simplex Model)



F-4-471

Preparation

1) Remove the Left Cover (Simplex Model) (Refer to page 4-144).

Procedure

1) Remove the Wireless LAN Unit [1].

- 1 Flat Cable [2]
- 1 Screw (black TP) [3]

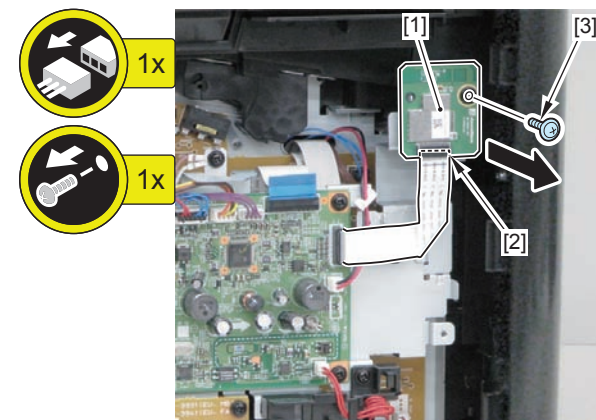

F-4-472

Removing the Paper Leading Edge Sensor (Simplex Model)

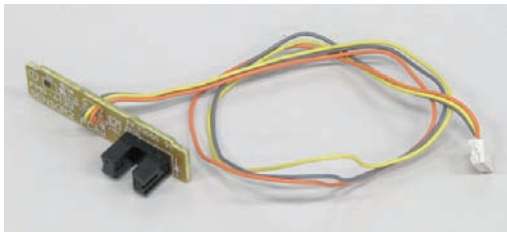

F-4-473

Preparation

- 1) Remove the Left Cover (Simplex Model) (Refer to page 4-144).
- 2-1) Remove the SADF Unit + Reader Unit (SADF Model) (Refer to page 4-51).
- 2-2) Remove the Copyboard Cover + Reader Unit (Copyboard Model) (Refer to page 4-76).
- 3) Remove the Right Cover (Simplex Model) (Refer to page 4-147).
- 4) Remove the Front Cover Unit (Simplex Model) (Refer to page 4-147).
- 5) Remove the Upper Cover (Simplex Model) (Refer to page 4-147).
- 6) Remove the Rear Cover (Simplex Model) (Refer to page 4-149).
- 7) Remove the Main Controller PCB (Simplex Model) (Refer to page 4-159).
- 8) Remove the FAX NCU PCB (FAX Model 120/230V) (Simplex Model) (Refer to page 4-161).

Procedure

- 1) Remove the Wireless LAN Unit [1] (Wifi Model).
 - 1 Screw (black TP) [2]
 - 2 Hooks [3]

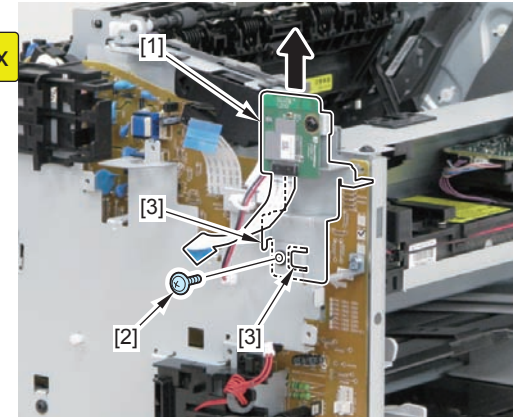

F-4-474

- 2) Remove the Main Controller PCB Installation Plate [1].
 - 1 Wire Saddle [2]
 - 4 Screws (with washer) [3]
 - 2 Screws (black TP) [4]

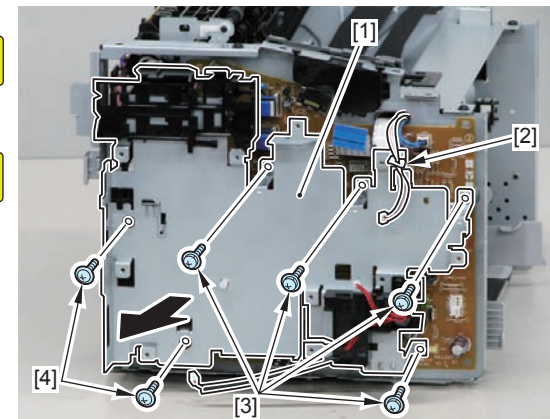

F-4-475

3) Free the harness [1] from the Harness Guide [A].

- 1 Terminal [2]

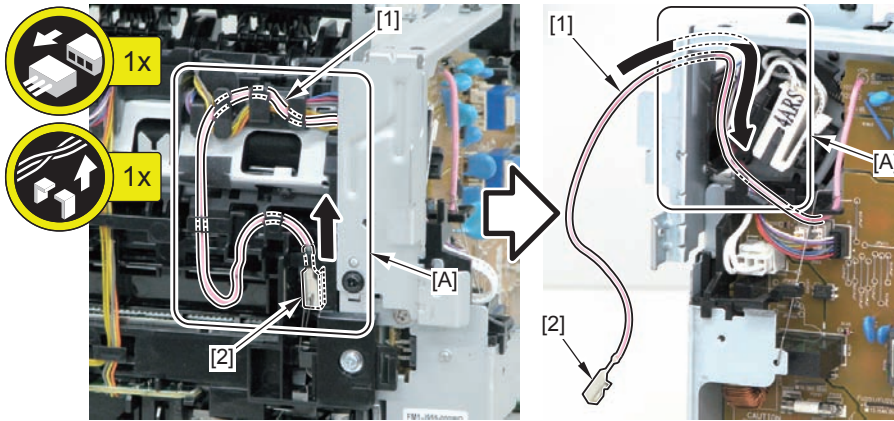

F-4-476

CAUTION:

Be sure that the terminal [2] is in contact with the Contact Spring [3].

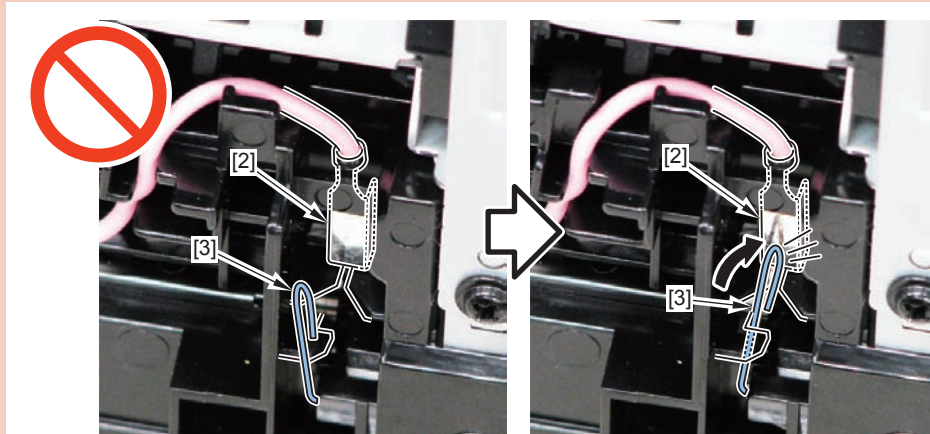

F-4-477

4) Remove the Harness Retaining Spring [1] from the 2 hooks [2].

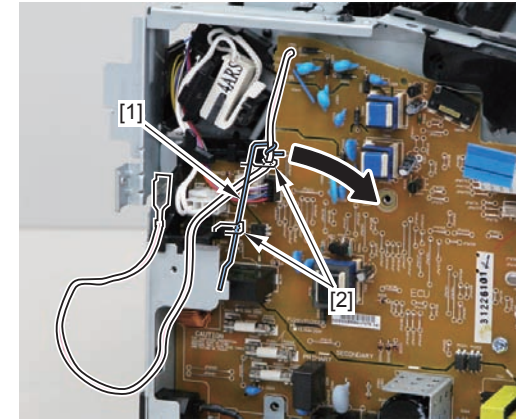

F-4-478

5) Disconnect the 4 connectors [1].

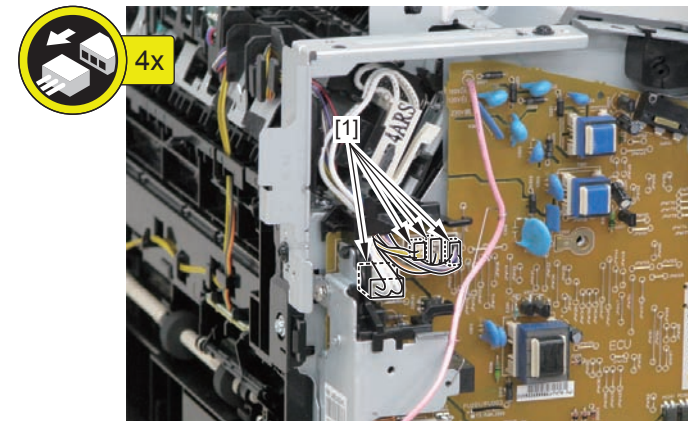

F-4-479

- 6) Free the harness [1] from the guide [A].
 - 7) Remove the Paper Leading Edge Sensor PCB [2].
- 2 Claws [3]

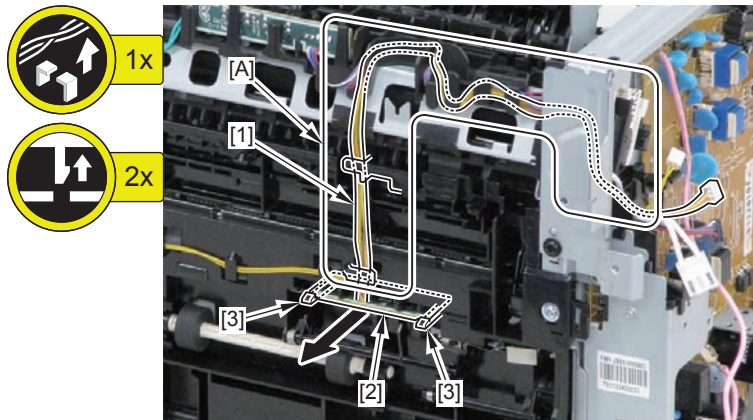

F-4-480

NOTE:

The following shows how to route the harness.

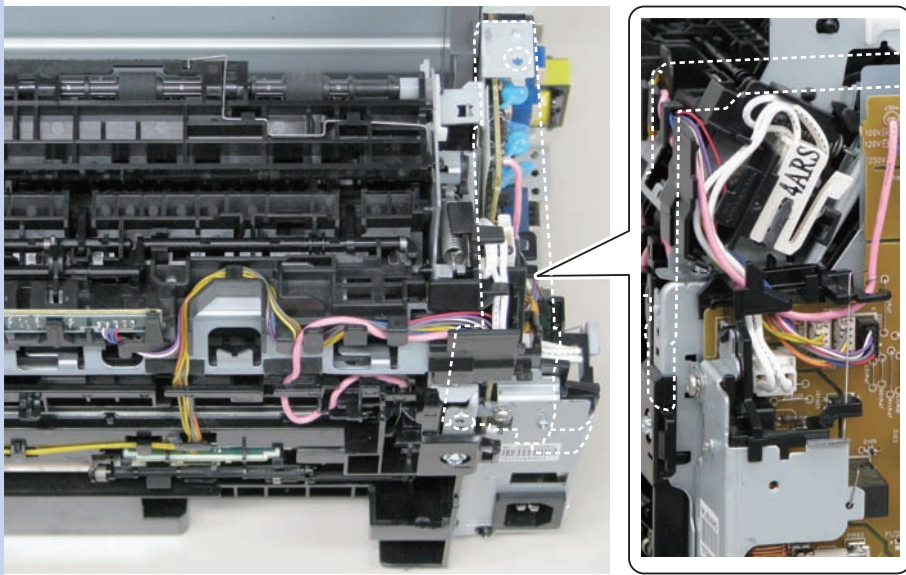

F-4-481

Removing the Fixing Delivery/Paper Width Sensor PCB (Simplex Model)

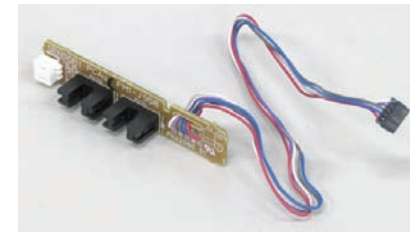

F-4-482

Preparation

- 1) Remove the Left Cover (Simplex Model) (Refer to page 4-144).
- 2-1) Remove the SADF Unit + Reader Unit (SADF Model) (Refer to page 4-51).
- 2-2) Remove the Copyboard Cover + Reader Unit (Copyboard Model) (Refer to page 4-76).
- 3) Remove the Right Cover (Simplex Model) (Refer to page 4-147).
- 4) Remove the Front Cover Unit (Simplex Model) (Refer to page 4-147).
- 5) Remove the Upper Cover (Simplex Model) (Refer to page 4-147).
- 6) Remove the Rear Cover (Simplex Model) (Refer to page 4-149).
- 7) Remove the Main Controller PCB (Simplex Model) (Refer to page 4-159).
- 8) Remove the FAX NCU PCB (FAX Model 120/230V) (Simplex Model) (Refer to page 4-161).

Procedure

1) Remove the Wireless LAN Unit [1] (Wifi Model).

- 1 Screw (black TP) [2]
- 2 Hooks [3]

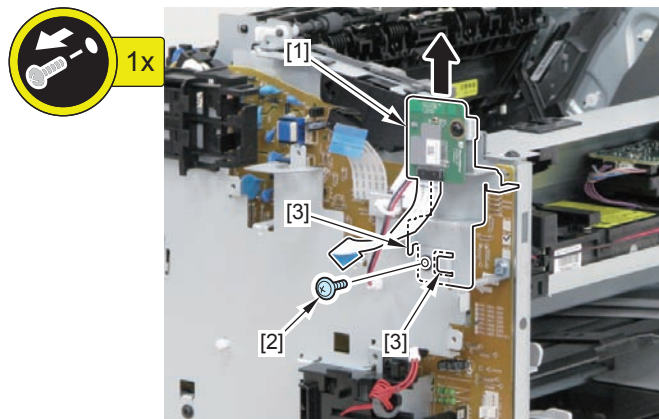

F-4-483

2) Remove the Main Controller PCB Installation Plate [1].

- 1 Wire Saddle [2]
- 4 Screws (with washer) [3]
- 2 Screws (black TP) [4]

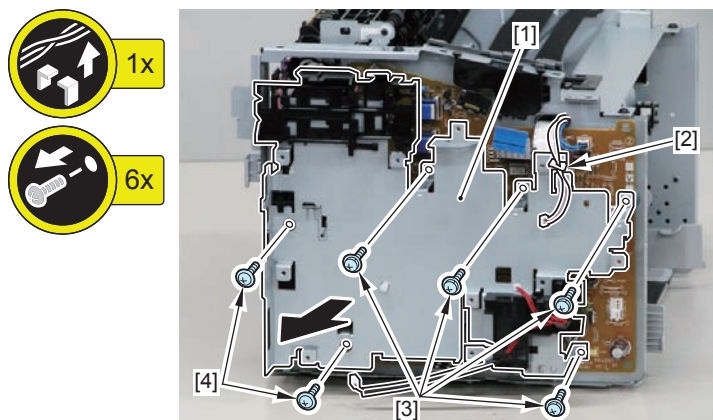

F-4-484

3) Free the harness [1] from the Harness Guide [A].

- 1 Terminal [2]

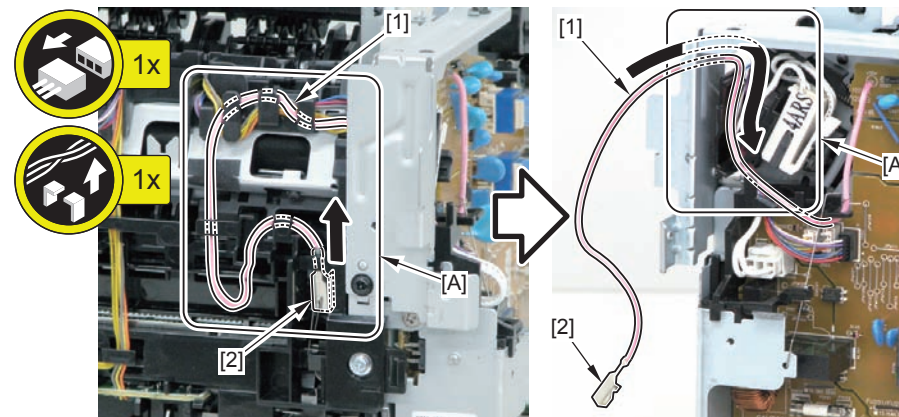

F-4-485

CAUTION:

Be sure that the terminal [2] is in contact with the Contact Spring [3].

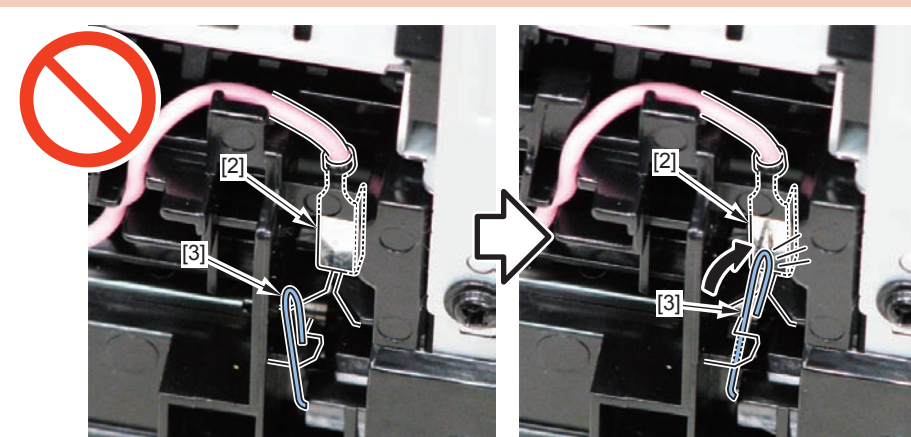

F-4-486

4) Remove the Harness Retaining Spring [1] from the 2 hooks [2].

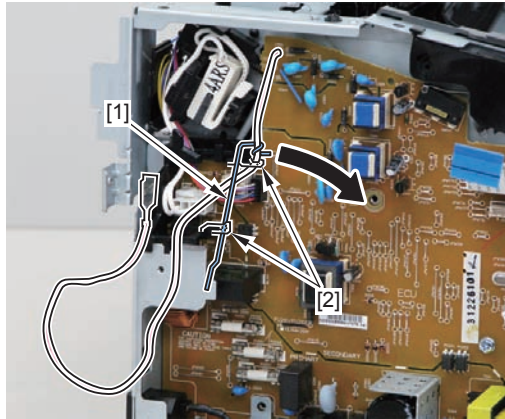

F-4-487

5) Disconnect the 4 connectors [1].

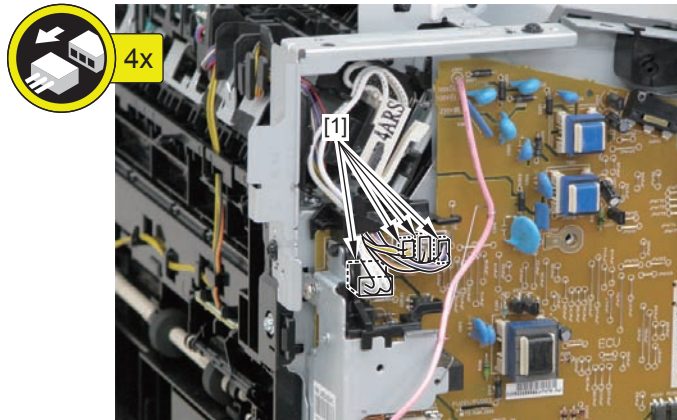

F-4-488

6) Free the harness [1] from the guide [A].

7) Remove the Fixing Delivery/Paper Width Sensor PCB [2].

- 1 Connector [3]
- 2 Claws [4]

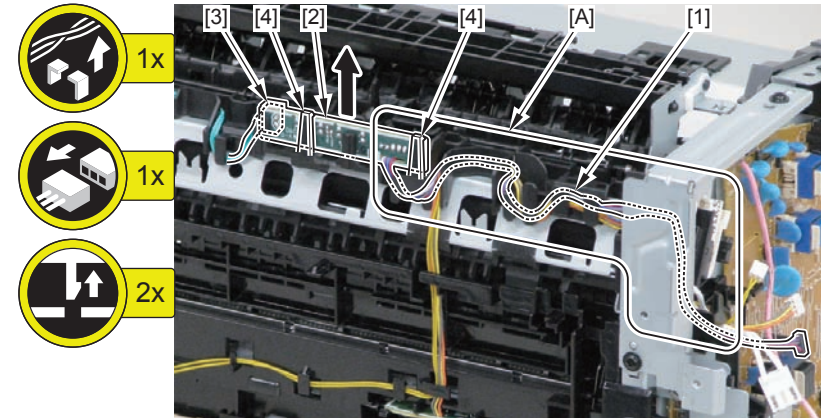

F-4-489

NOTE:

The following shows how to route the harness.

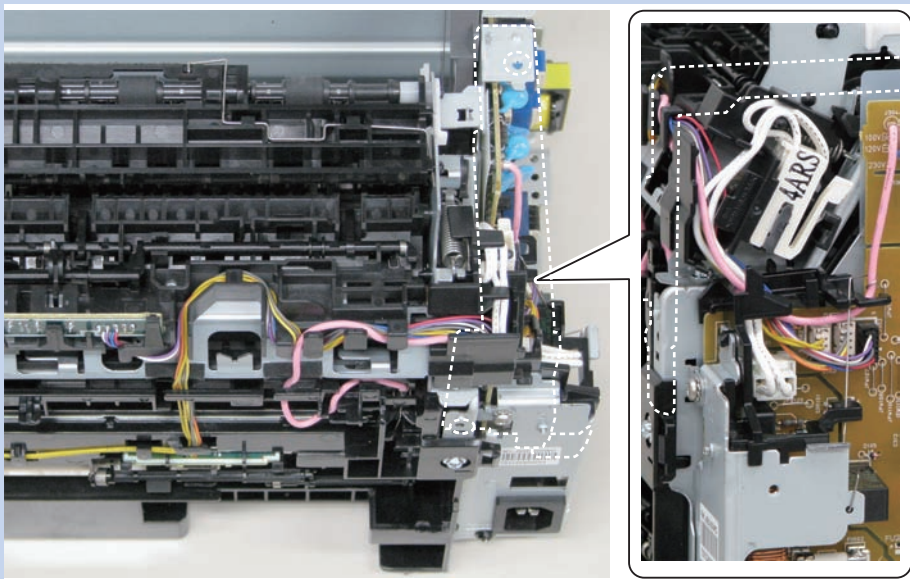

F-4-490

Removing the Toner Sensor and Multi Pickup Sensor Unit (Fax Model + Simplex Model)

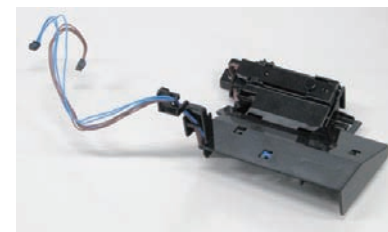

F-4-491

Preparation

- 1) Remove the Left Cover (Simplex Model) (Refer to page 4-144).
- 2-1) Remove the SADF Unit + Reader Unit (SADF Model) (Refer to page 4-51).
- 2-2) Remove the Copyboard Cover + Reader Unit (Copyboard Model) (Refer to page 4-76).
- 3) Remove the Right Cover (Simplex Model) (Refer to page 4-147).
- 4) Remove the Front Cover Unit (Simplex Model) (Refer to page 4-147).
- 5) Remove the Upper Cover (Simplex Model) (Refer to page 4-147).

Procedure

1) Remove the Wireless LAN Unit [1] (Wifi Model).

- 1 Flat Cable [2]
- 1 Screw (black TP) [3]
- 2 Hooks [4]

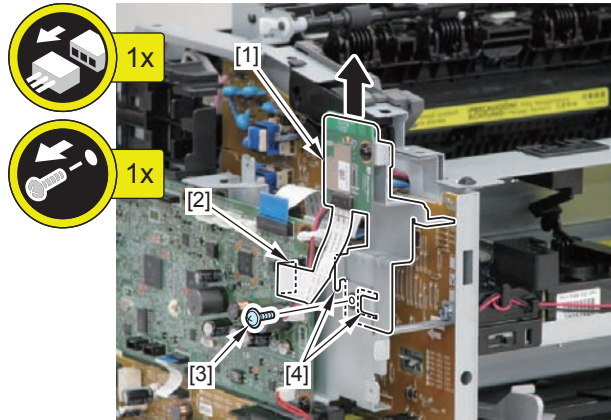

F-4-492

2) Remove the Scanner Cover [1].

- 2 Screws (black TP) [2]

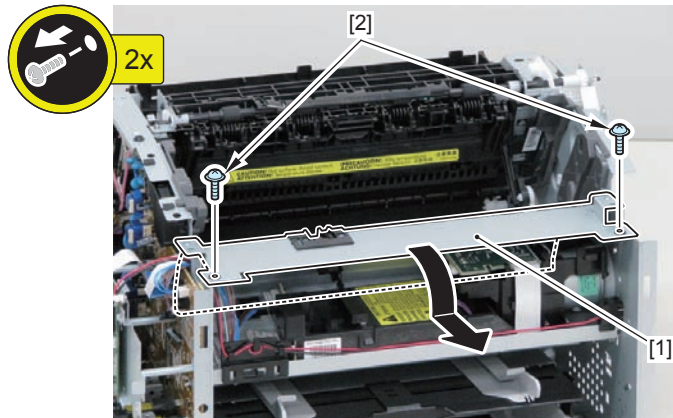

F-4-493

NOTE: How to assemble the Scanner Cover

- 1) Be sure to pass the Shutter Open/Close Lever [3] through the hole [A] of the Scanner Cover.

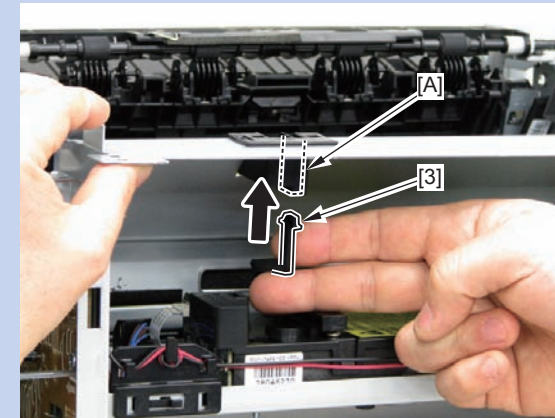

F-4-494

- 2) Be sure that the Shutter Open/Close Lever [3] can move vertically.

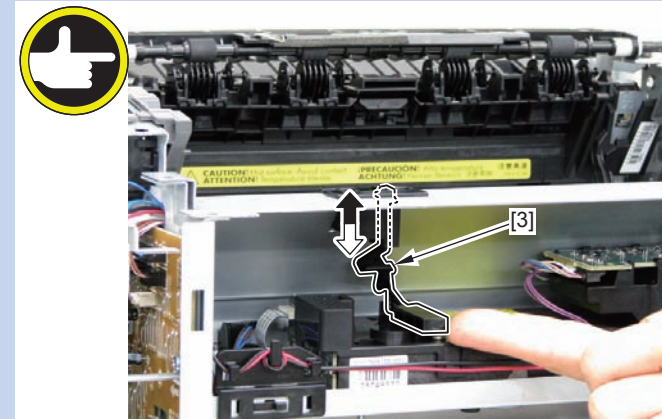

F-4-495

3) Pass the harness [1] through the hole [A] of the Left Side Plate to the inside.

- 1 Connector [2]
- 1 Connector [3] (Fax Model)

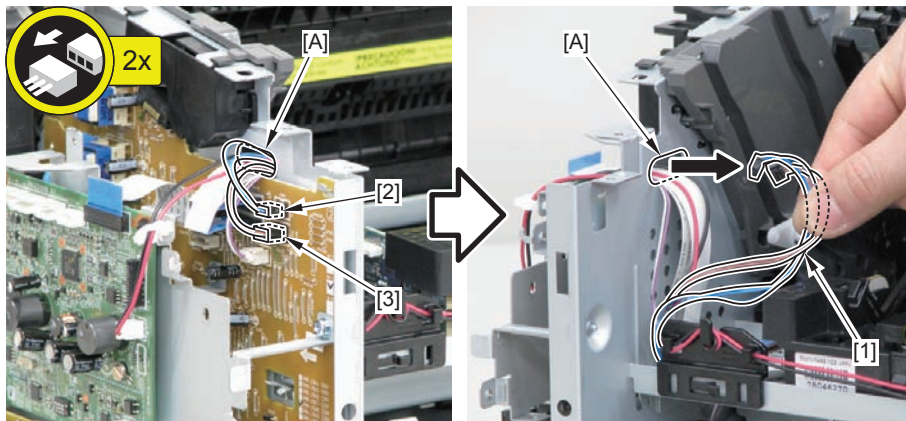

F-4-496

4) Remove the Multi Pickup Sensor Unit [1].

- 1 Wire Saddle [2]
- 1 Claw [3]
- 3 Hooks [4]

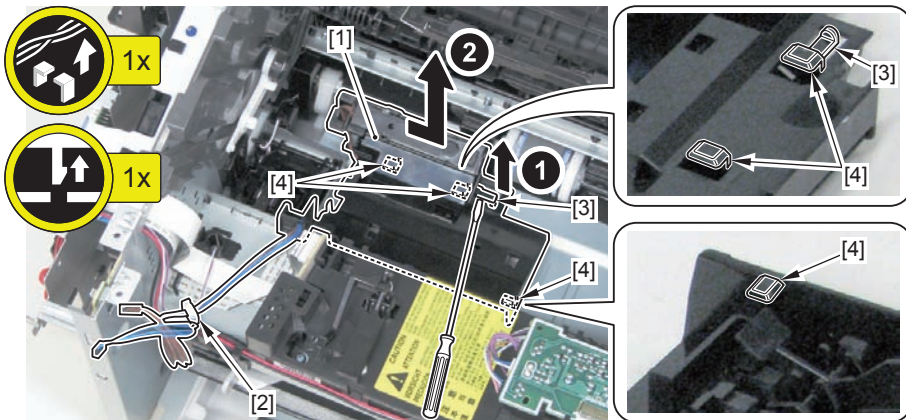

F-4-497

Removing the Speaker (Fax Model + Simplex Model)

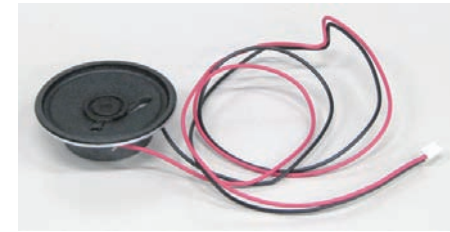

F-4-498

Preparation

- 1) Remove the Left Cover (Simplex Model) (Refer to page 4-144).
- 2) Remove the Right Cover (Simplex Model) (Refer to page 4-147).
- 3) Remove the Front Cover Unit (Simplex Model) (Refer to page 4-147).

Procedure

- 1) Disconnect the Speaker Harness [1], and pass it through the hole [A] of the Left Side Plate to the inside.
 - 1 Connector [2]
 - 1 Wire Saddle [3]

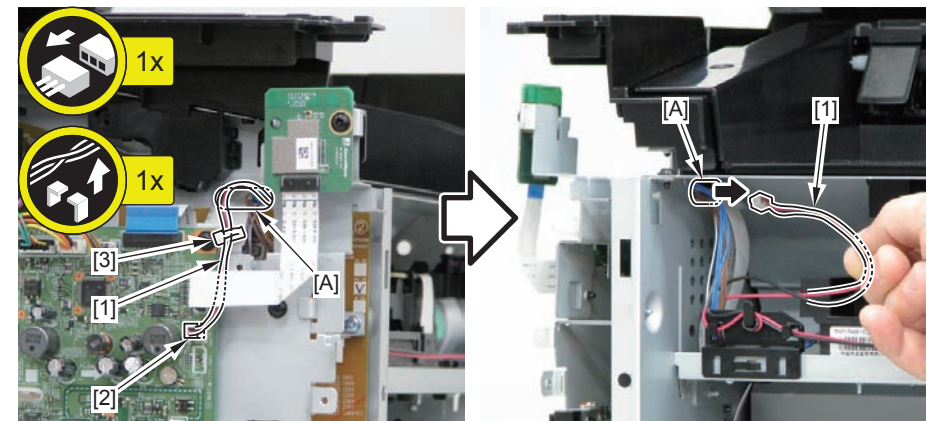

F-4-499

2) Free the Speaker Harness [1] from the Harness Guide [A], and pass it through the hole [B] of the Right Plate to the outside.

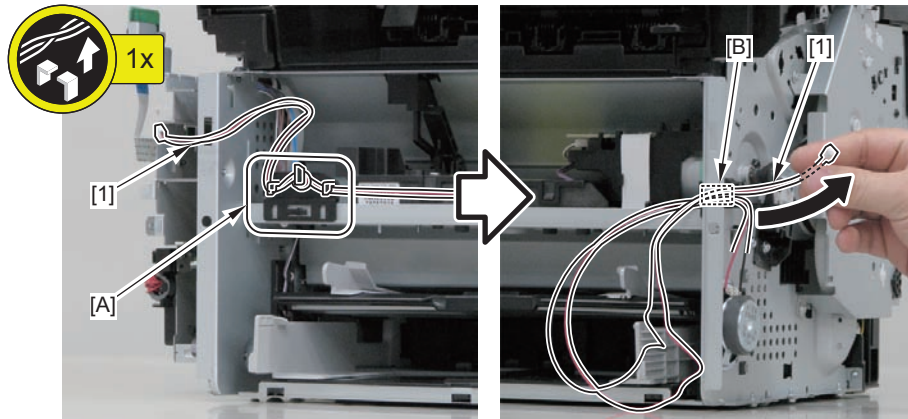

F-4-500

3) Remove the speaker [1].

- 1 Screw [2]
- 2 Hook [3]

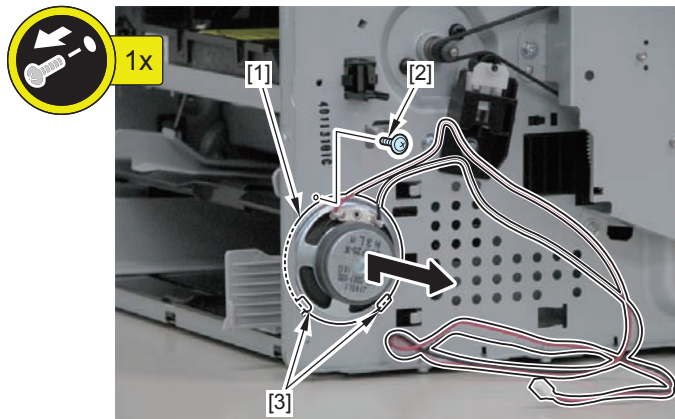

F-4-501

NOTE: How to assemble the speaker

Be sure to assemble it with the harness [1] routed upwards.

Otherwise, the connector of the Speaker Harness cannot reach the Main Controller.

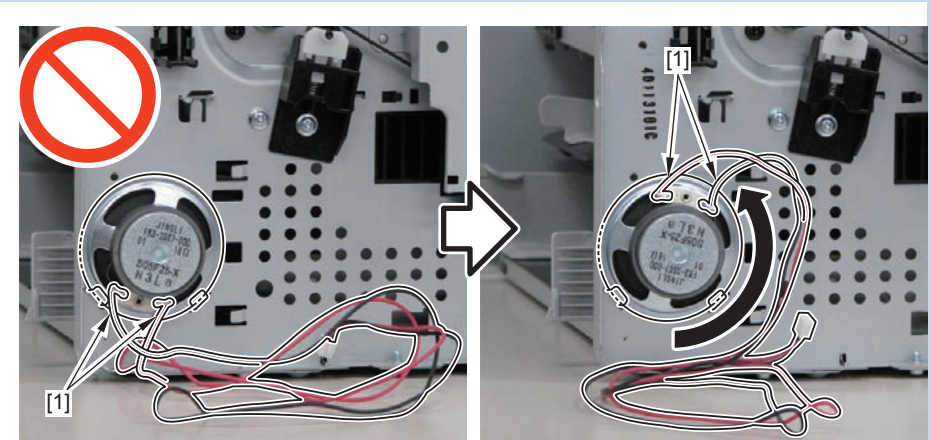

F-4-502

Laser Exposure System (Simplex Model)

Layout Drawing

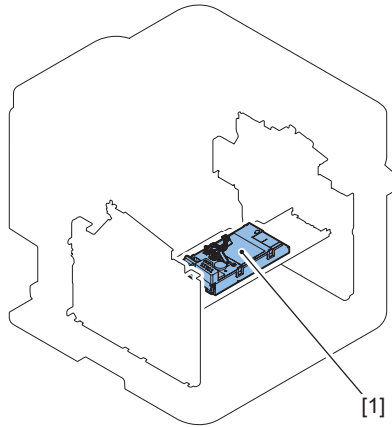

F-4-503

No.	Name	Reference	Remarks
[1]	Laser Scanner Unit	(Refer to page 4-171)	

T-4-50

Removing the Laser Scanner Unit (Simplex Model)



F-4-504

Preparation

- 1) Remove the Left Cover (Simplex Model) (Refer to page 4-144).
- 2-1) Remove the SADF Unit + Reader Unit (SADF Model) (Refer to page 4-51).
- 2-2) Remove the Copyboard Cover + Reader Unit (Copyboard Model) (Refer to page 4-76).
- 3) Remove the Right Cover (Simplex Model) (Refer to page 4-147).
- 4) Remove the Front Cover Unit (Simplex Model) (Refer to page 4-147).
- 5) Remove the Upper Cover (Simplex Model) (Refer to page 4-147).

Procedure

CAUTION:

Do not disassemble the Laser Scanner Unit because it requires adjustment.

1) Remove the Scanner Cover [1].

- 2 Screws (black TP) [2]

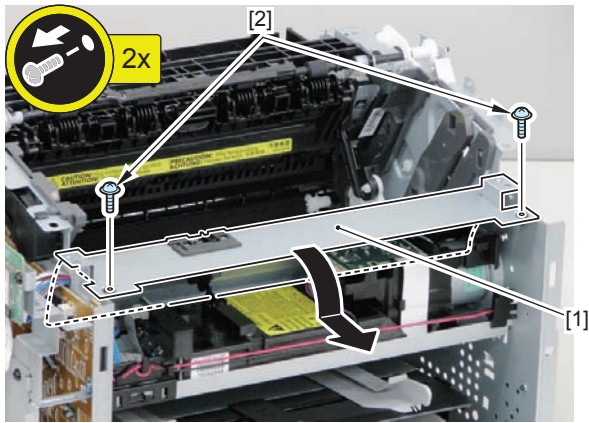

F-4-505

2) Move the Laser Scanner Unit [1].

- 4 Screws [2]

3) Remove the Laser Scanner Unit [1].

- 1 Flat Cable [3]
- 1 Sponge [4]
- 1 Connector [5]

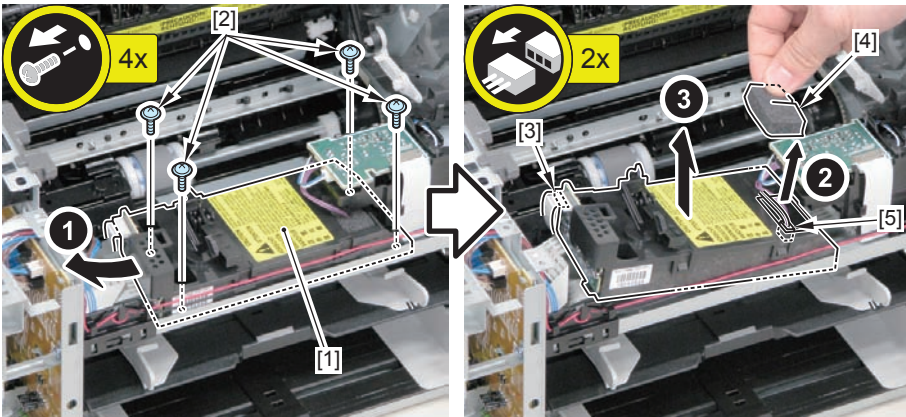

F-4-506

NOTE: How to assemble the Scanner Cover

- 1) Be sure to pass the Shutter Open/Close Lever [3] through the hole [A] of the Scanner Cover.

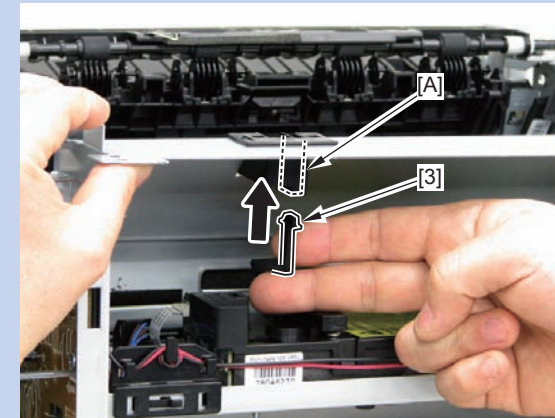

F-4-507

- 2) Be sure that the Shutter Open/Close Lever [3] can move vertically.

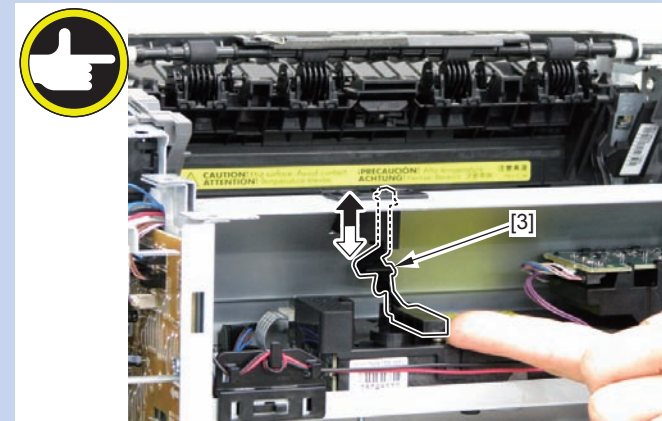

F-4-508

Image Formation System (Simplex Model)

Layout Drawing

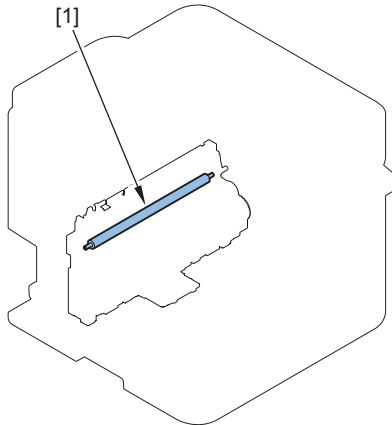

F-4-509

No.	Name	Reference	Remarks
[1]	Transfer Roller	(Refer to page 4-173)	

T-4-51

Removing the Transfer Roller (Simplex Model)



F-4-510

Procedure

CAUTION:

Do not touch the surface of the Transfer Roller.

- 1-1) Open the SADF Unit + Reader Unit [1] and Delivery Tray [2] (SADF Model).
 - 1-2) Open the Copyboard Cover + Reader Unit [1] and Delivery Tray [2] (Copyboard Model).
 - 2) Remove the bushing [3] of the Transfer Roller.
- 2 Claws [4]

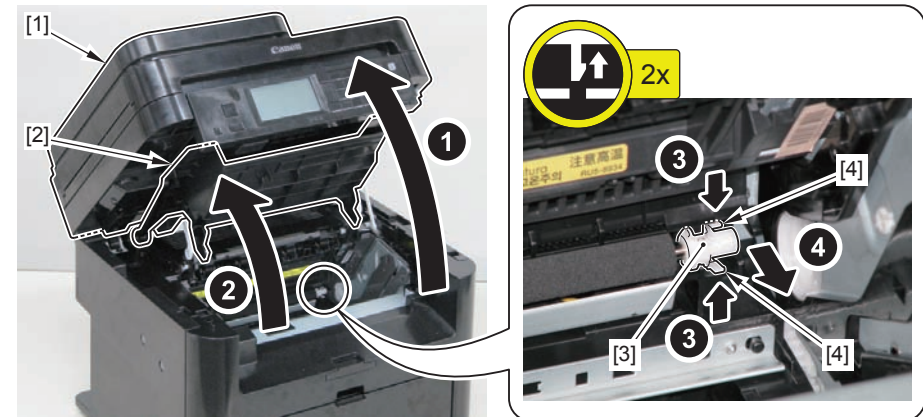

F-4-511

3) Hold both ends of the shaft [1] of the Transfer Roller, and remove the Transfer Roller [2].

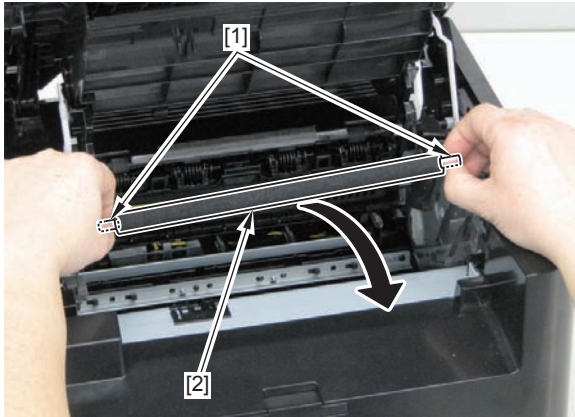

F-4-512

CAUTION:

Be sure that the bushing [1] is facing the correct direction when assembling.

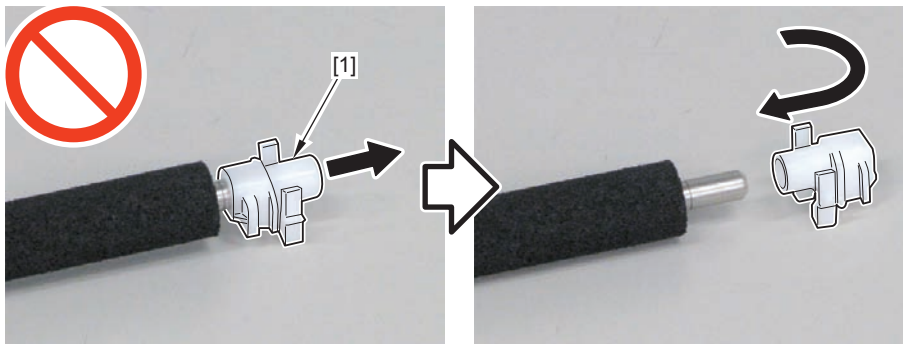

F-4-513

NOTE: How to assemble the Transfer Roller

Be sure to assemble it by aligning the spring [1] with the boss [2].

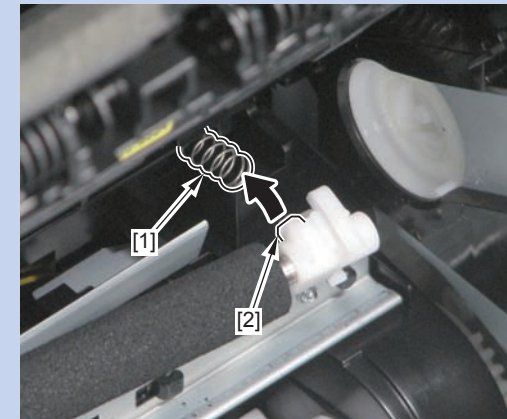

F-4-514

Fixing System (Simplex Model)

Layout Drawing

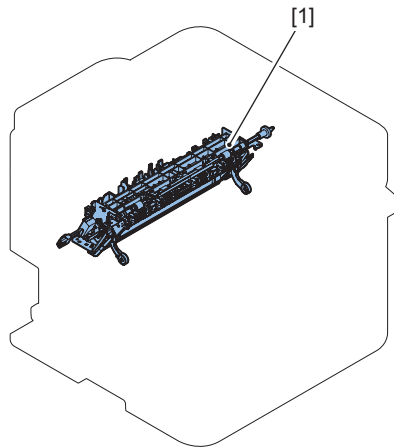

F-4-515

No.	Name	Reference	Remarks
[1]	Fixing Unit	(Refer to page 4-175)	

T-4-52

Removing the Fixing Assembly (Simplex Model)

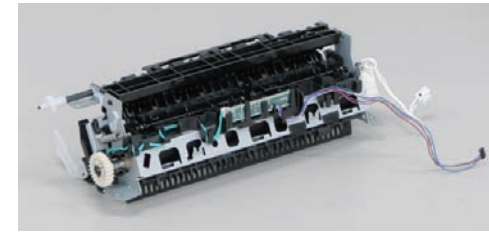

F-4-516

Preparation

- 1) Remove the Left Cover (Simplex Model) (Refer to page 4-144).
- 2-1) Remove the SADF Unit + Reader Unit (SADF Model) (Refer to page 4-51).
- 2-2) Remove the Copyboard Cover + Reader Unit (Copyboard Model) (Refer to page 4-76).
- 3) Remove the Right Cover (Simplex Model) (Refer to page 4-147).
- 4) Remove the Front Cover Unit (Simplex Model) (Refer to page 4-147).
- 5) Remove the Upper Cover (Simplex Model) (Refer to page 4-147).
- 6) Remove the Rear Cover (Simplex Model) (Refer to page 4-149).
- 7) Remove the Main Controller PCB (Simplex Model) (Refer to page 4-159).
- 8) Remove the FAX NCU PCB (FAX Model 120/230V) (Simplex Model) (Refer to page 4-161).

Procedure

CAUTION:

- Be sure to start work after the Fixing Assembly is cooled down enough.
- The Fixing Assembly right after printing may cause burn injury.
- Do not disassemble the Fixing Assembly because it requires adjustment.

1) Remove the Wireless LAN Unit [1] (Wifi Model).

- 1 Screw (black TP) [2]
- 2 Hooks [3]

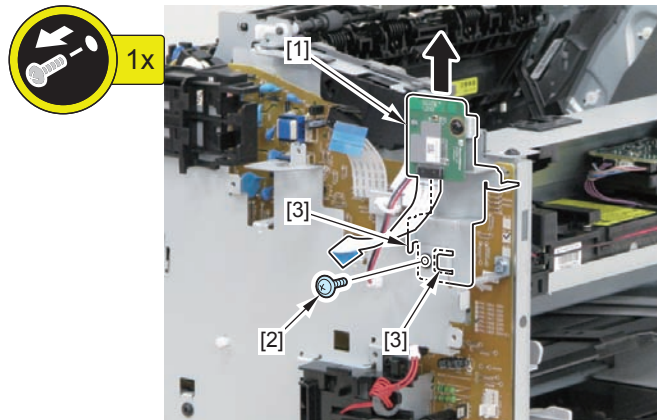

F-4-517

2) Remove the Main Controller PCB Installation Plate [1].

- 1 Wire Saddle [2]
- 4 Screws (with washer) [3]
- 2 Screws (black TP) [4]

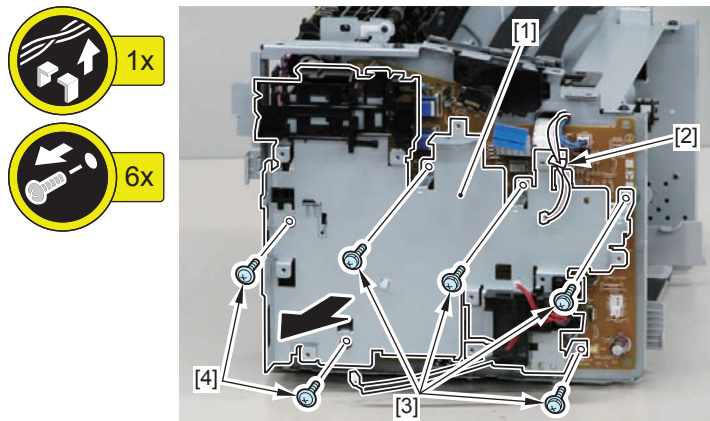

F-4-518

3) Free the harness [1] from the Harness Guide [A].

- 1 Terminal [2]

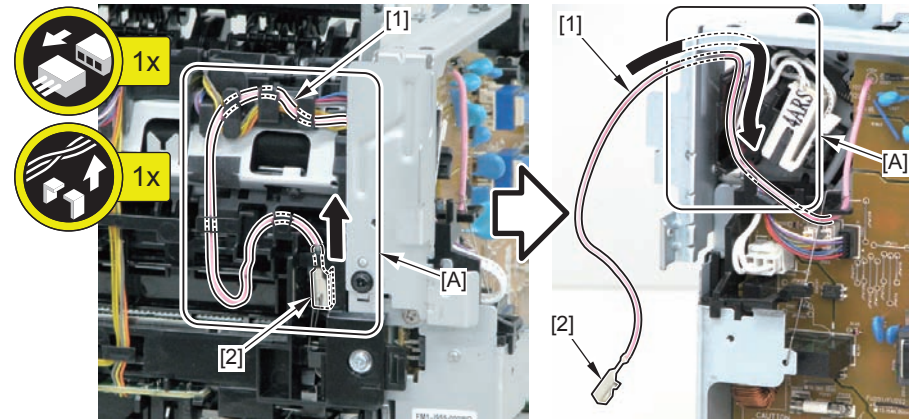

F-4-519

CAUTION:

Be sure that the terminal [2] is in contact with the Contact Spring [3].

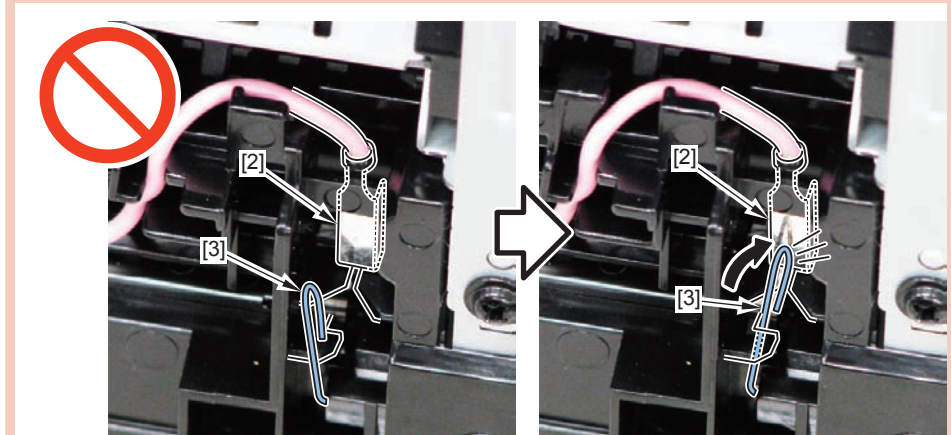

F-4-520

4) Remove the Harness Retaining Spring [1] from the 2 hooks [2].

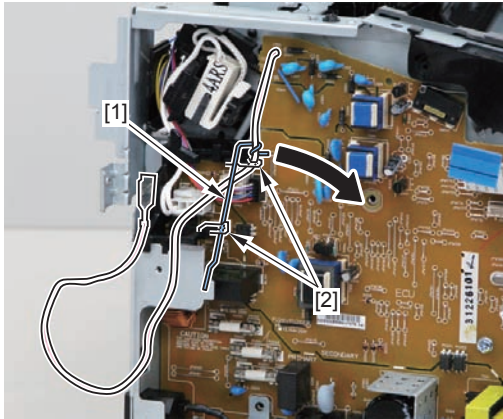

F-4-521

6) Disconnect the 4 connectors [1].

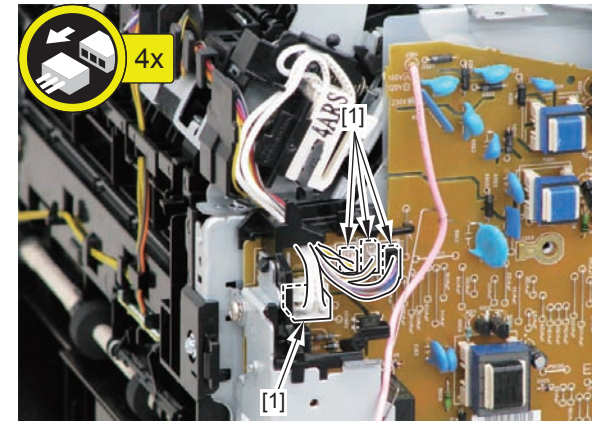

F-4-523

5) Remove the 2 Reinforcing Plates [1] (right and left).

- 4 Screws (black TP) [2]

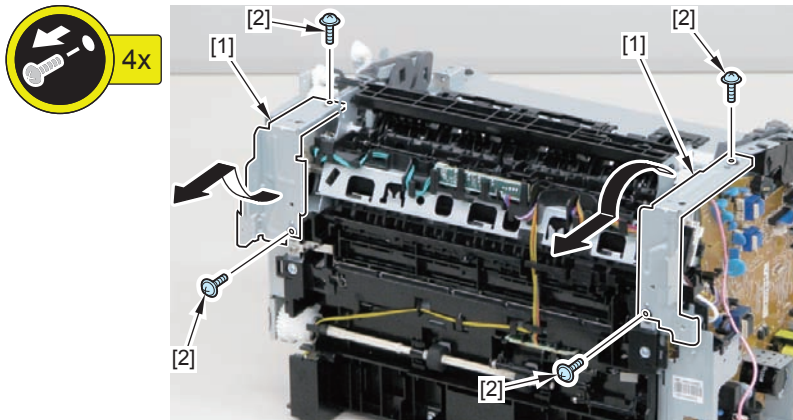

F-4-522

7) Free the harness [1] from the Harness Guide [A].

8) Free the Fixing Harness [2] from the Harness Holder [3].

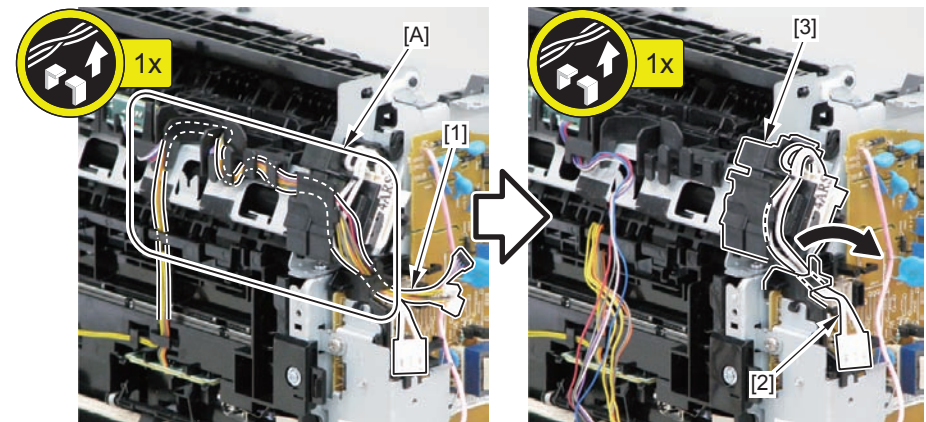

F-4-524

9) Remove the Harness Holder [1].

- 1 Claw [2]

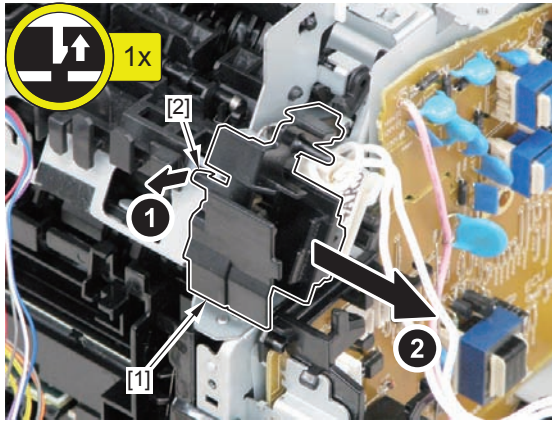

F-4-525

10) Remove the Shaft Support [1] of the Delivery Roller.

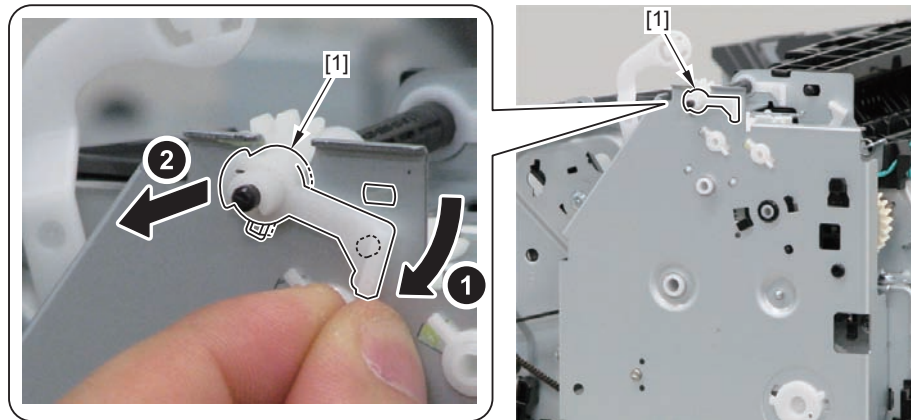

F-4-526

11) Remove the Fixing Assembly [1].

- 3 Screws [2]

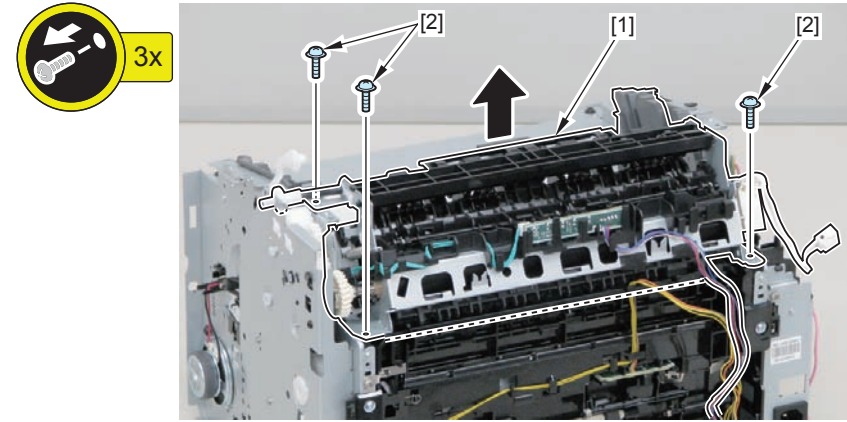

F-4-527

NOTE: How to install the Fixing Harness

- 1) Wrap the Fixing Harness [2] around the protrusion [1] of the Harness Holder.
- 2) Pass it through the Harness Guide [A], and then connect the connector [3].

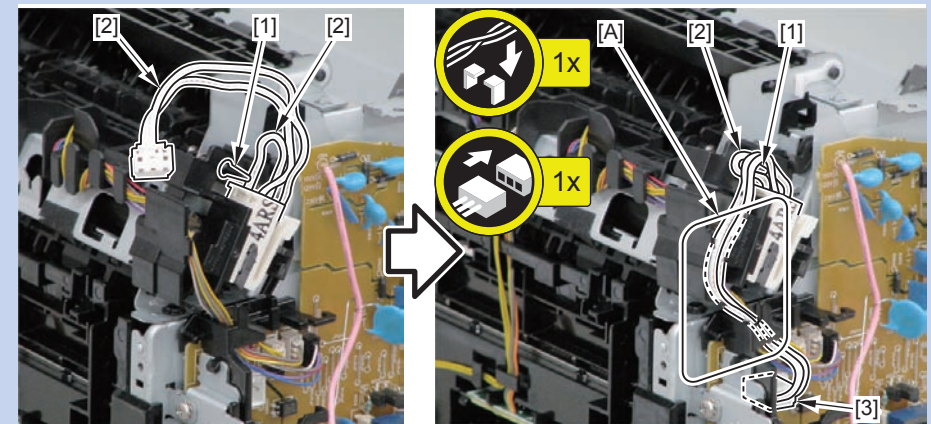

F-4-528

NOTE:

The following shows how to route the harness.

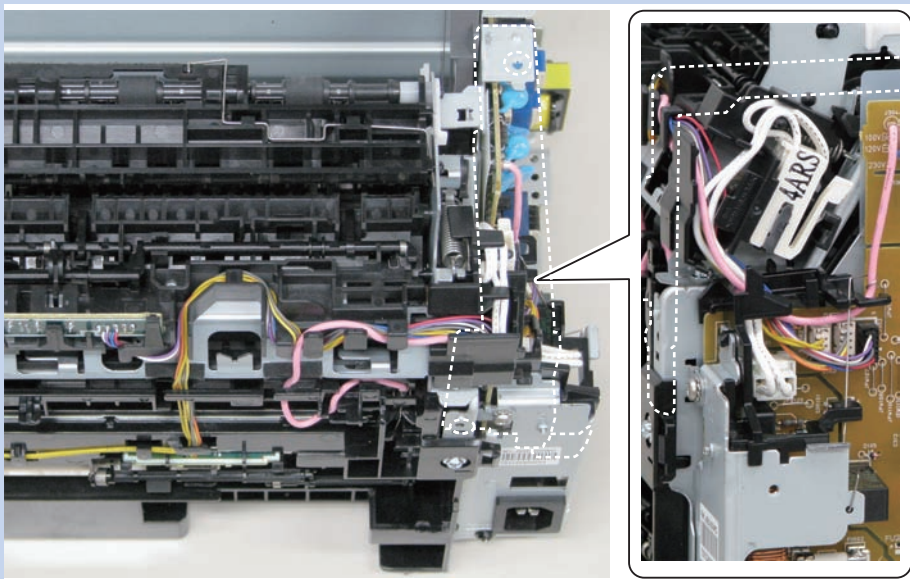

F-4-529

Pickup Feed System (Simplex Model)

Layout Drawing

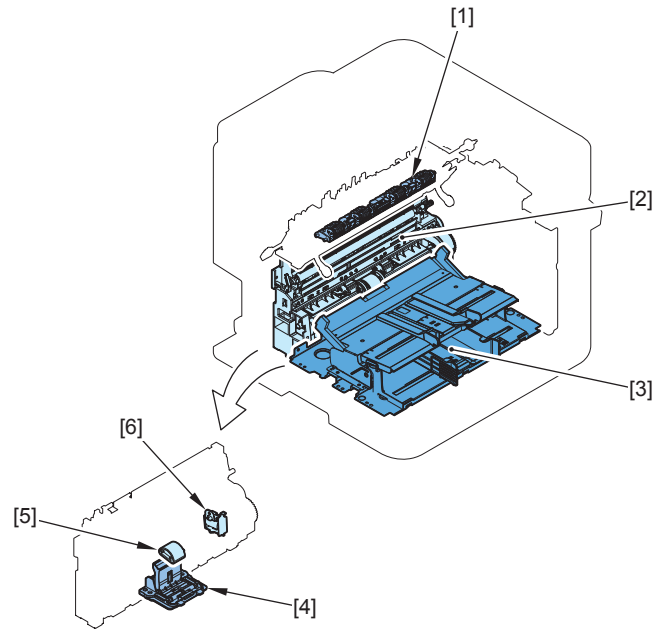

F-4-530

No.	Name	Reference	Remarks
[1]	Delivery Slave Roller Unit	(Refer to page 4-188)	
[2]	Pickup Unit	(Refer to page 4-180)	
[3]	Pickup Tray Unit	(Refer to page 4-184)	
[4]	Separation Pad	(Refer to page 4-187)	
[5]	Pickup Roller	(Refer to page 4-186)	
[6]	Pickup Solenoid	(Refer to page 4-190)	

T-4-53

Removing the Pickup Unit (Simplex Model)

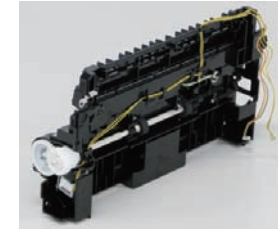

F-4-531

Preparation

- 1) Remove the Left Cover (Simplex Model) (Refer to page 4-144).
- 2-1) Remove the SADF Unit + Reader Unit (SADF Model) (Refer to page 4-51).
- 2-2) Remove the Copyboard Cover + Reader Unit (Copyboard Model) (Refer to page 4-76).
- 3) Remove the Right Cover (Simplex Model) (Refer to page 4-147).
- 4) Remove the Front Cover Unit (Simplex Model) (Refer to page 4-147).
- 5) Remove the Upper Cover (Simplex Model) (Refer to page 4-147).
- 6) Remove the Rear Cover (Simplex Model) (Refer to page 4-149).
- 7) Remove the Main Controller PCB (Simplex Model) (Refer to page 4-159).
- 8) Remove the FAX NCU PCB (FAX Model 120/230V) (Simplex Model) (Refer to page 4-161).
- 9) Remove the Separation Pad (Simplex Model) (Refer to page 4-187).

Procedure

1) Remove the Wireless LAN Unit [1] (Wifi Model).

- 1 Screw (black TP) [2]
- 2 Hooks [3]

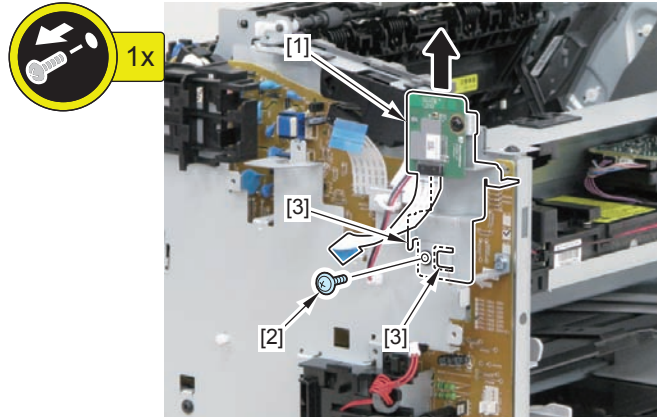

F-4-532

2) Remove the Main Controller PCB Installation Plate [1].

- 1 Wire Saddle [2]
- 4 Screws (with washer) [3]
- 2 Screws (black TP) [4]

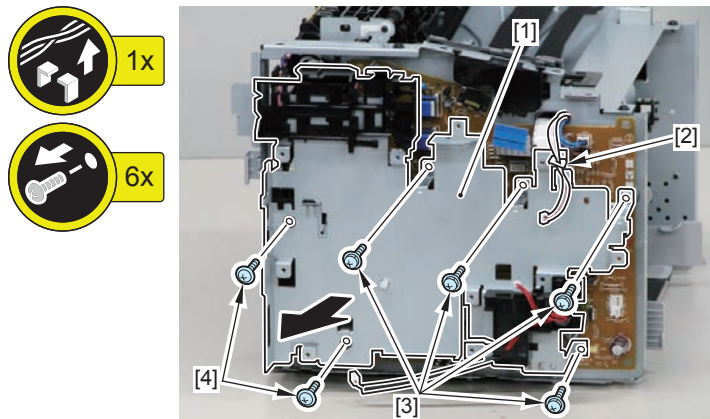

F-4-533

3) Free the harness [1] from the Harness Guide [A].

- 1 Terminal [2]

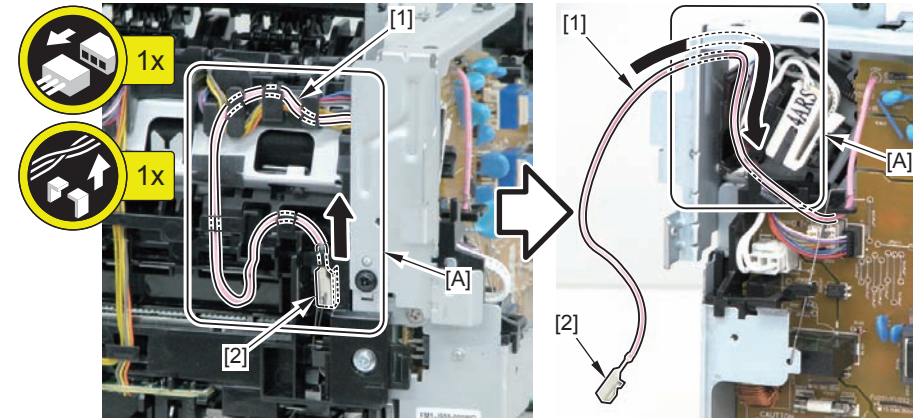

F-4-534

CAUTION:

Be sure that the terminal [2] is in contact with the Contact Spring [3].

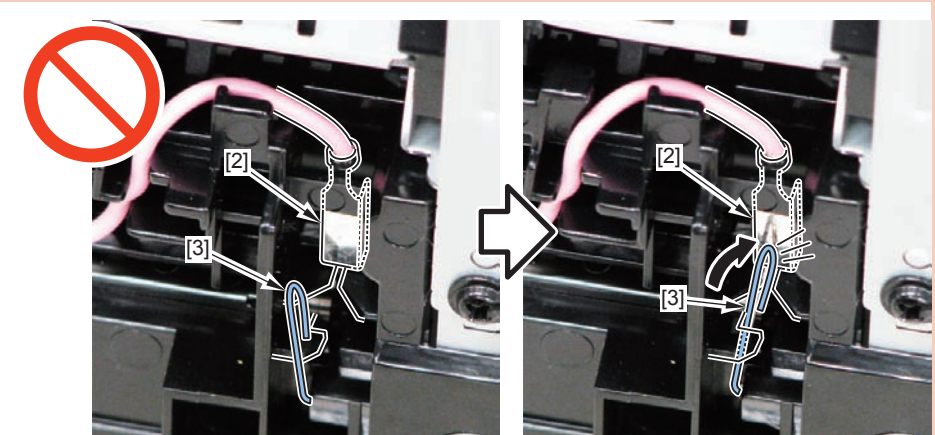

F-4-535

4) Remove the Harness Retaining Spring [1] from the 2 hooks [2].

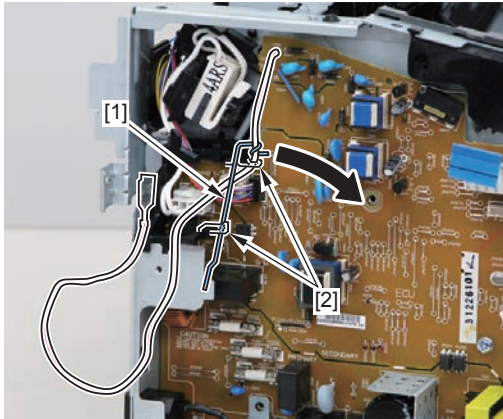

F-4-536

6) Free the harness [1] from the Harness Guide [A].

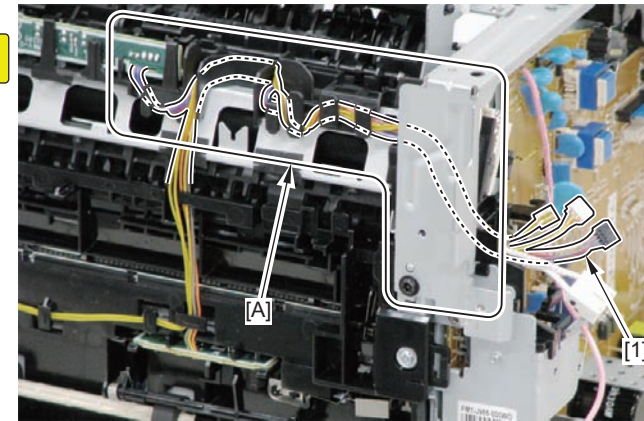

F-4-538

5) Disconnect the 4 connectors [1].

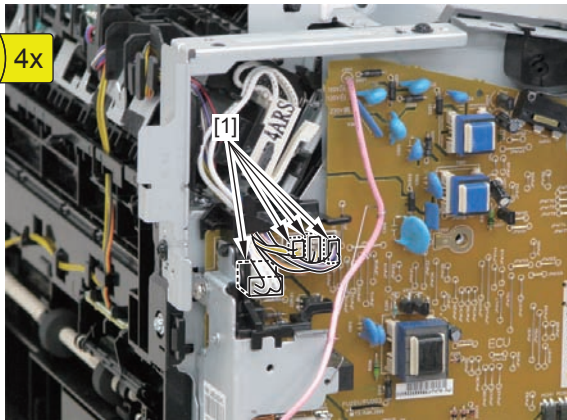

F-4-537

7) Remove the Shaft Retainer [1].

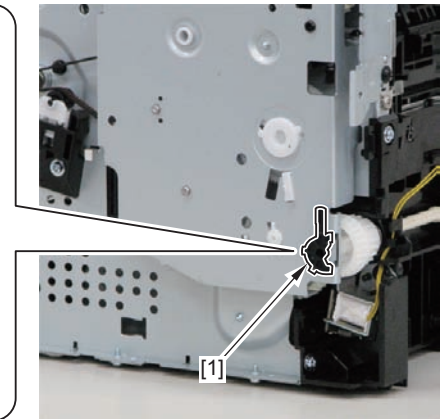
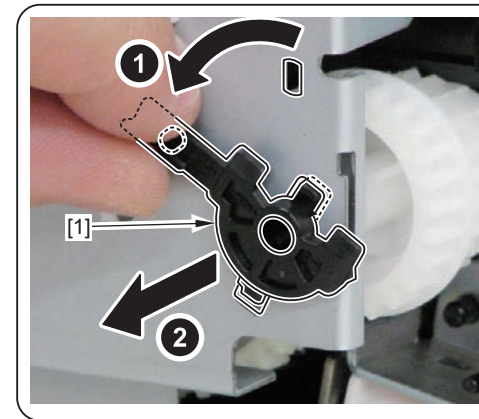

F-4-539

8) Turn the machine so that it is placed with its front side down.

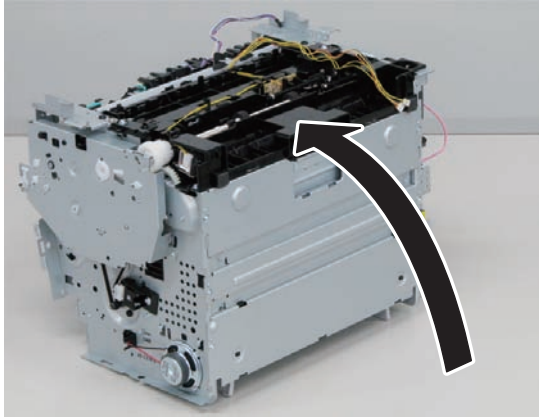

F-4-540

9) Remove the 6 screws (TP) [1] and the screw (with toothed lock washer) [2].

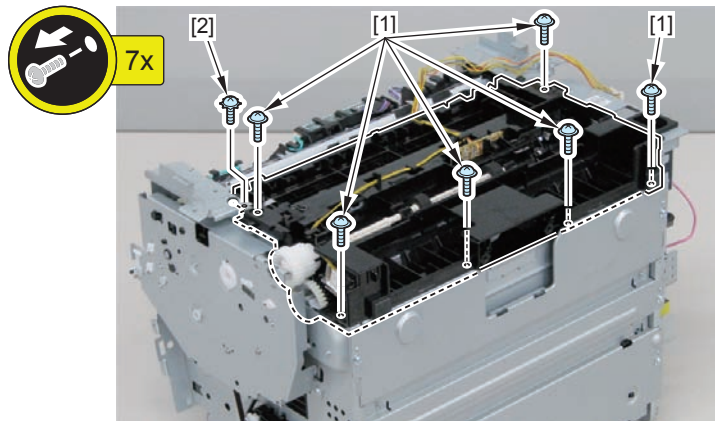

F-4-541

10) Remove the Pickup Unit [2] while opening the Pickup Tray [1].

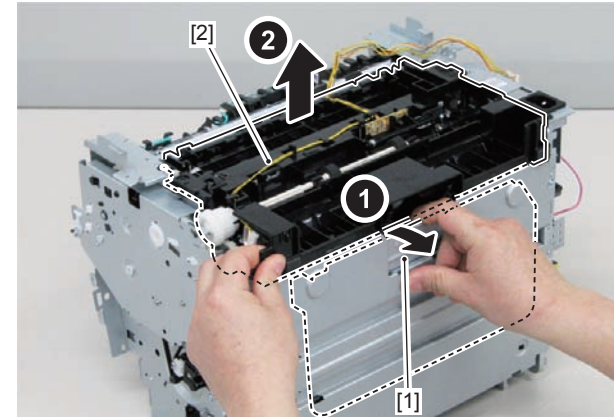

F-4-542

CAUTION:

- When installing the Pickup Unit [1], be sure that the Contact Spring [2] is in contact with the [A] part.
- Be sure to make the contact point [3] of the grounding come in contact with the [B] part.
- Be sure to install the Pickup Unit [1] while holding the Pickup Tray [4].
(This is because the tension of the spring is applied to the Pickup Tray.)

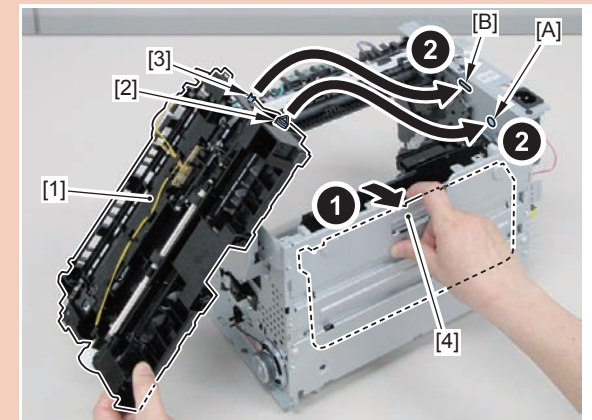

F-4-543

NOTE:

The following shows how to route the harness.

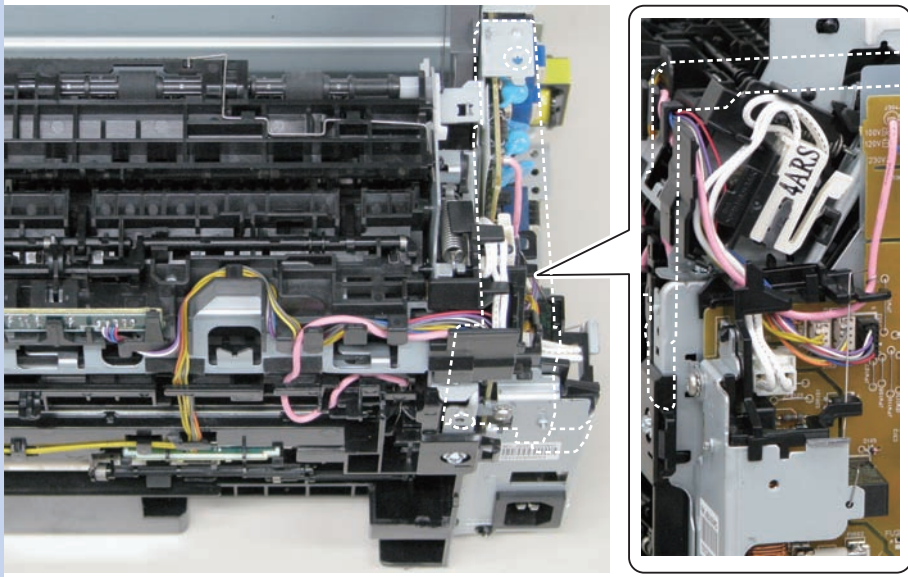

F-4-544

Removing the Pickup Tray Unit (Simplex Model)

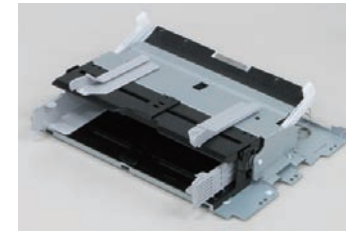

F-4-545

Preparation

- 1) Remove the Left Cover (Simplex Model) (Refer to page 4-144).
- 2-1) Remove the SADF Unit + Reader Unit (SADF Model) (Refer to page 4-51).
- 2-2) Remove the Copyboard Cover + Reader Unit (Copyboard Model) (Refer to page 4-76).
- 3) Remove the Right Cover (Simplex Model) (Refer to page 4-147).
- 4) Remove the Front Cover Unit (Simplex Model) (Refer to page 4-147).
- 5) Remove the Upper Cover (Simplex Model) (Refer to page 4-147).
- 6) Remove the Rear Cover (Simplex Model) (Refer to page 4-149).
- 7) Remove the Separation Pad (Simplex Model) (Refer to page 4-187).

Procedure

- 1) Remove the 4 screws (black TP) [1] and the 6 screws [2].

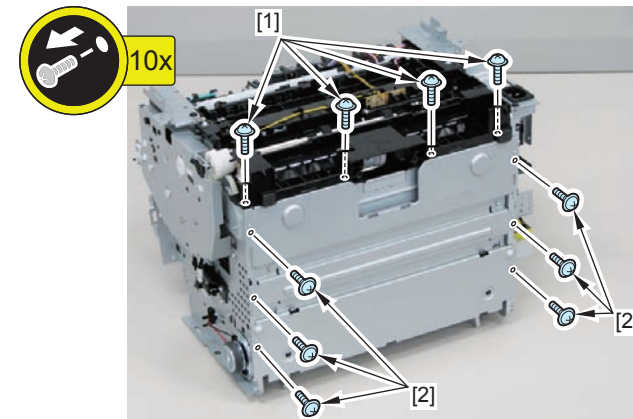

F-4-546

2) Remove the Pickup Unit [2] while holding the Pickup Tray Unit [1] toward the front.

- 2 Boss Holes [3]
- 2 Hooks [4]
- 2 Bosses [5]

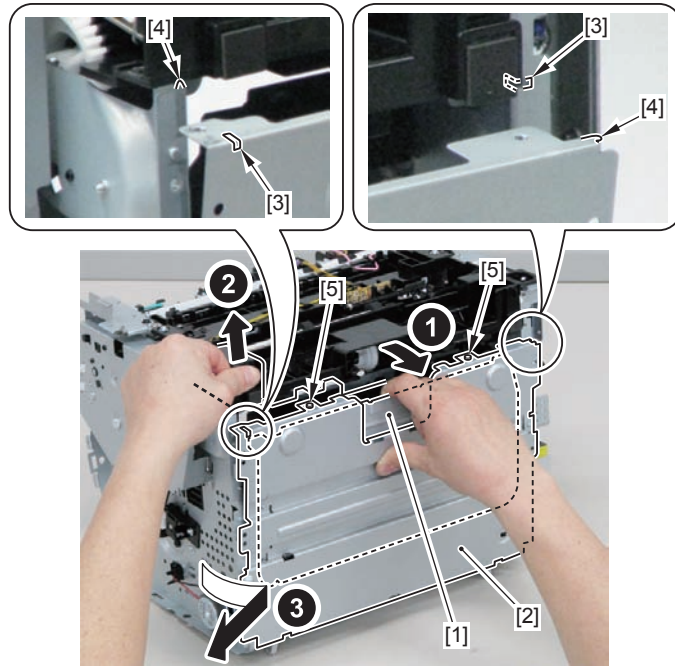

F-4-547

NOTE: How to assemble the Pickup Tray Unit

- 1) While holding the pickup tray [1] together, assemble it by aligning the 2 hooks [4] with the 2 Boss Holes [3] and the 2 bosses [5] with the Pickup Unit [2].

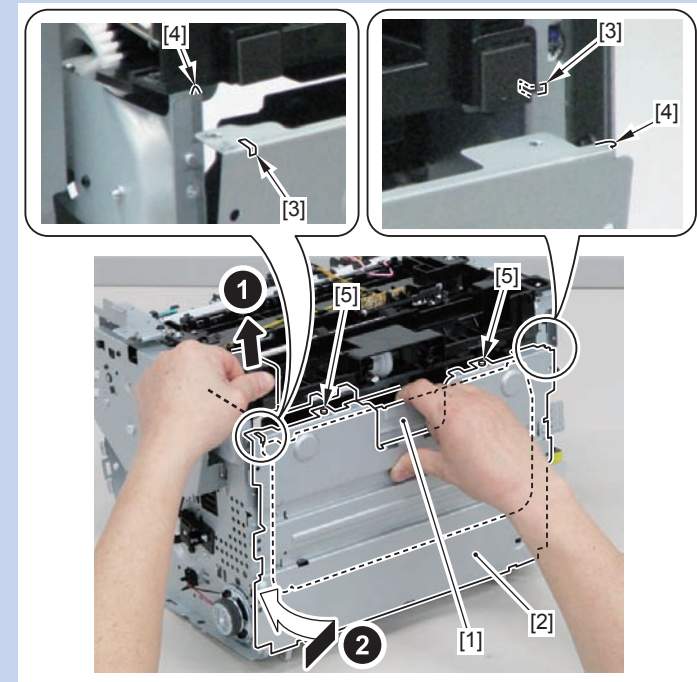

F-4-548

NOTE: How to assemble the Pickup Tray Unit

- 2) Fix the 6 screws [6] in the following order.
- 3) Be sure to check the positioning of the 6 bosses [7] when installing the Pickup Tray Unit.

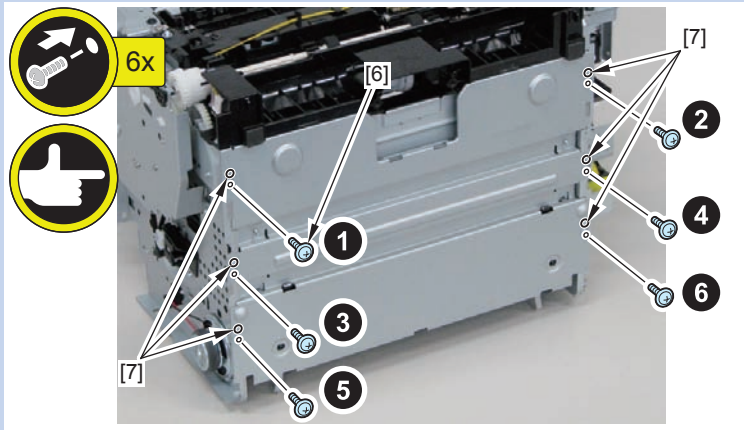

F-4-549

Removing the Pickup Roller (Simplex Model)

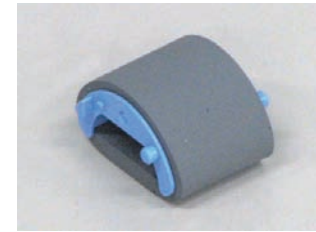

F-4-550

Procedure

CAUTION:

- Do not touch the surface of the Pickup Roller.
- Do not touch the Transfer Roller [1].

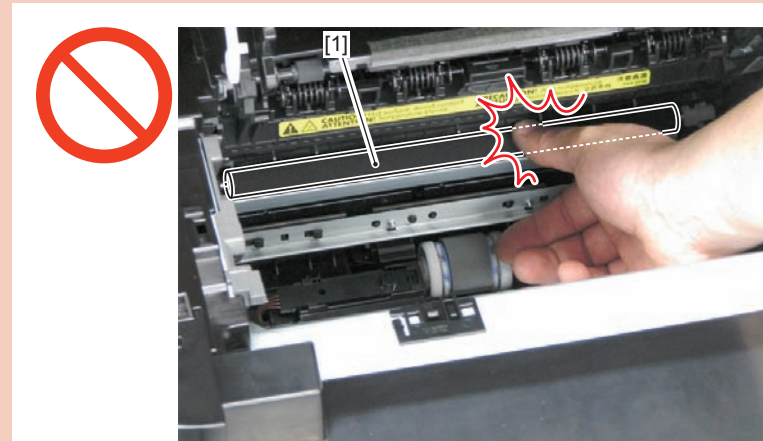

F-4-551

- 1-1) Open the SADF + Reader Unit [1] and the Delivery Tray [2] (SADF Model).
 1-2) Open the Copyboard Cover + Reader Unit [1] and the Delivery Tray [2] (Copyboard Model).
 2) Remove the Pickup Roller [3].
 • 2 Claws [4]

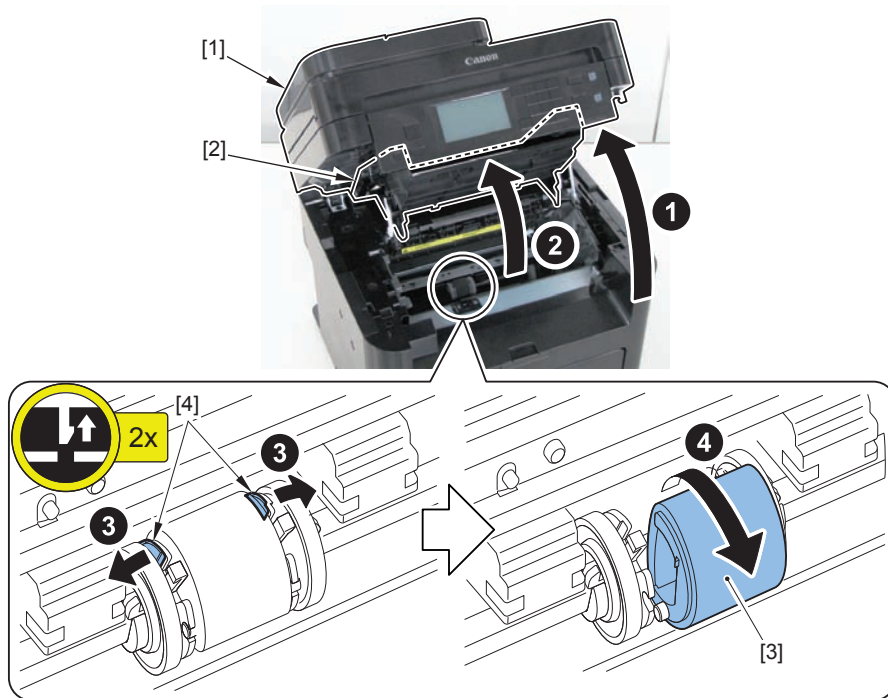

F-4-552

Removing the Separation Pad (Simplex Model)



F-4-553

Procedure

CAUTION:

Do not touch the surface of the Separation Pad.

- 1) Turn the machine so that it is placed with its left side down.
 2-1) Hold and open the SADF Unit + Reader Unit [1] (SADF Model).
 2-1) Hold and open the Copyboard Unit + Reader Unit [1] (Copyboard Model).

CAUTION:

Turning the machine sideways may release the tension of the hinge of the SADF Unit [2] and cause the units to open suddenly.

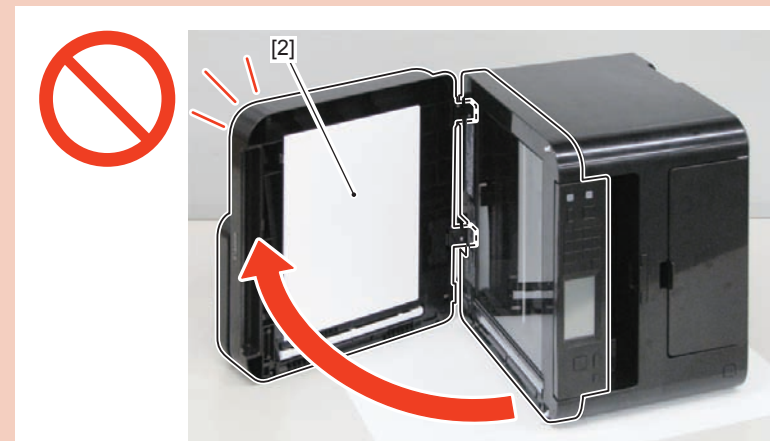

F-4-554

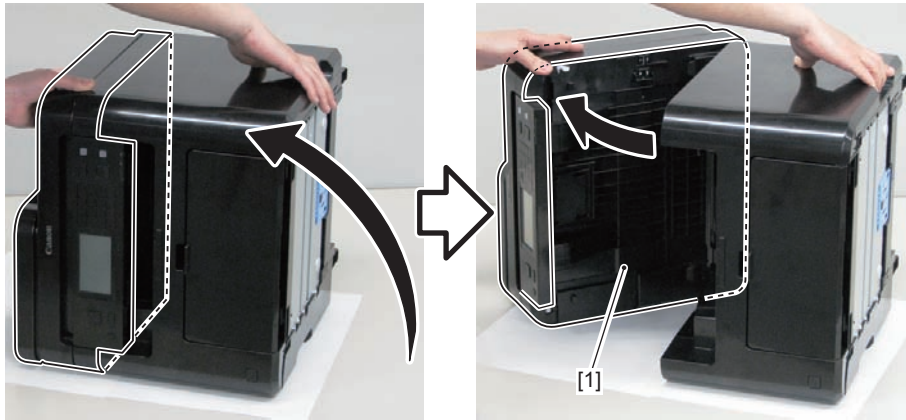

F-4-555

3) Remove the Separation Pad [1].

- 2 Screws [2]
- 2 Hooks [3]

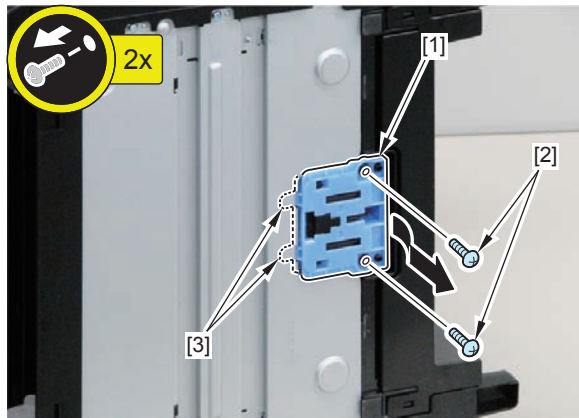

F-4-556

Removing the Delivery Slave Roller Unit (Simplex Model)



F-4-557

Procedure

1-1) Open the SADF + Reader Unit [1] and the Delivery Tray [2] (SADF Model).

1-2) Open the Copyboard Cover + Reader Unit [1] and the Delivery Tray [2] (Copyboard Model).

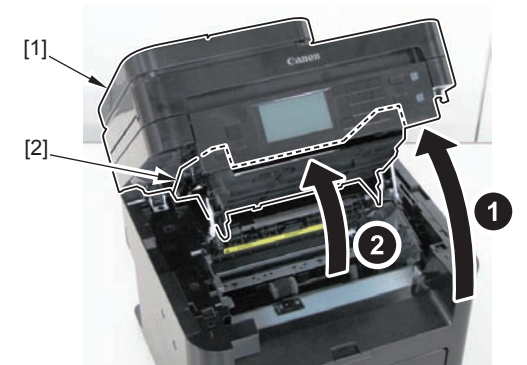

F-4-558

2) Remove the Delivery Slave Roller Unit [1].

- 2 Shafts [2]

CAUTION:

Do not damage the Delivery Slave Roller Unit [1] by bending it too much.

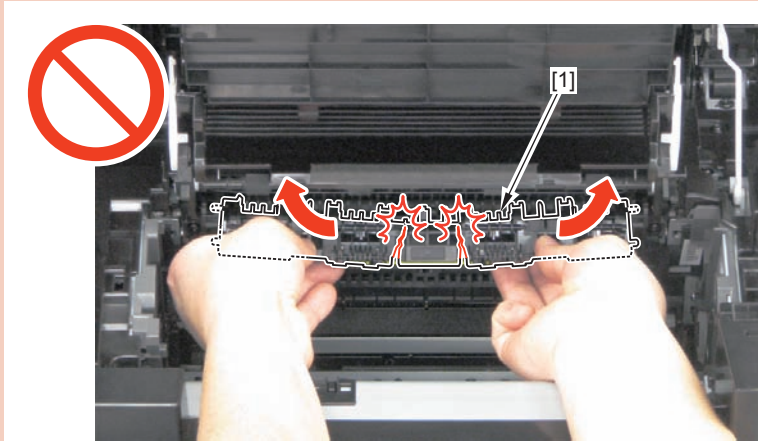

F-4-559

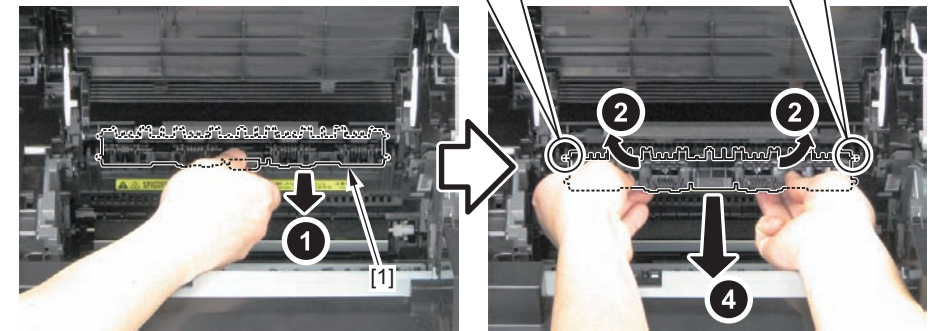
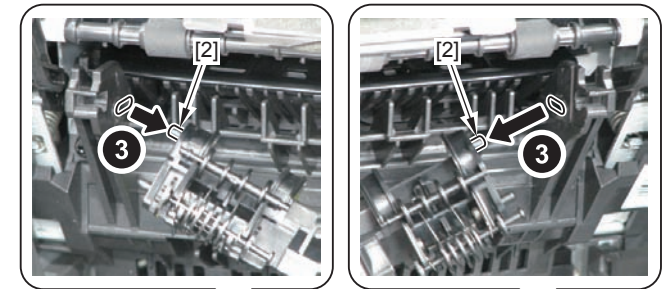

F-4-560

Removing the Pickup Solenoid (Simplex Model)

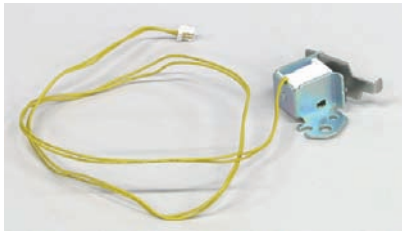

F-4-561

Preparation

- 1) Remove the Left Cover (Simplex Model) (Refer to page 4-144).
- 2-1) Remove the SADF Unit + Reader Unit (SADF Model) (Refer to page 4-51).
- 2-2) Remove the Copyboard Cover + Reader Unit (Copyboard Model) (Refer to page 4-76).
- 3) Remove the Right Cover (Simplex Model) (Refer to page 4-147).
- 4) Remove the Front Cover Unit (Simplex Model) (Refer to page 4-147).
- 5) Remove the Upper Cover (Simplex Model) (Refer to page 4-147).
- 6) Remove the Rear Cover (Simplex Model) (Refer to page 4-149).
- 7) Remove the Main Controller PCB (Simplex Model) (Refer to page 4-159).
- 8) Remove the FAX NCU PCB (FAX Model 120/230V) (Simplex Model) (Refer to page 4-161).

Procedure

- 1) Remove the Wireless LAN Unit [1] (Wifi Model).
 - 1 Screw (black TP) [2]
 - 2 Hooks [3]

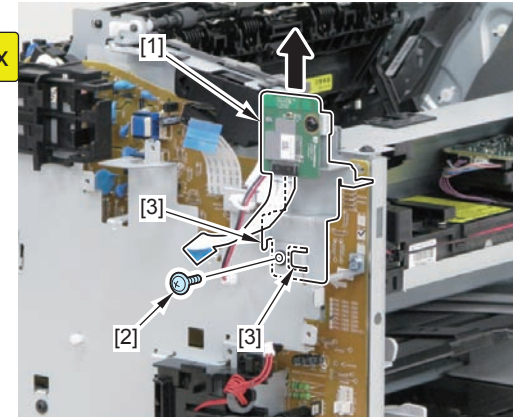

F-4-562

- 2) Remove the Main Controller PCB Installation Plate [1].
 - 1 Wire Saddle [2]
 - 4 Screws (with washer) [3]
 - 2 Screws (black TP) [4]

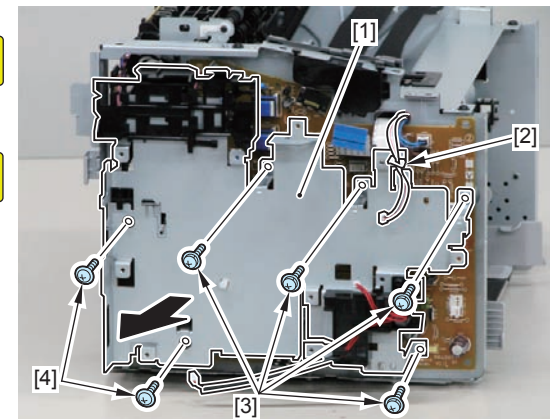

F-4-563

3) Free the harness [1] from the Harness Guide [A].

- 1 Terminal [2]

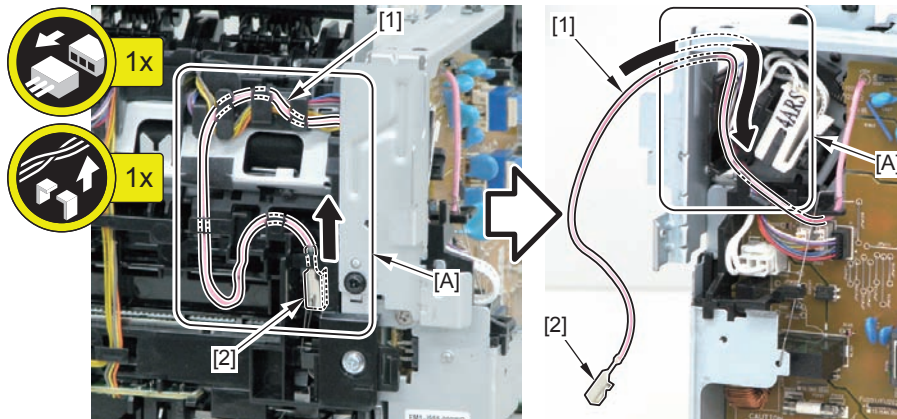

F-4-564

CAUTION:

Be sure that the terminal [2] is in contact with the Contact Spring [3].

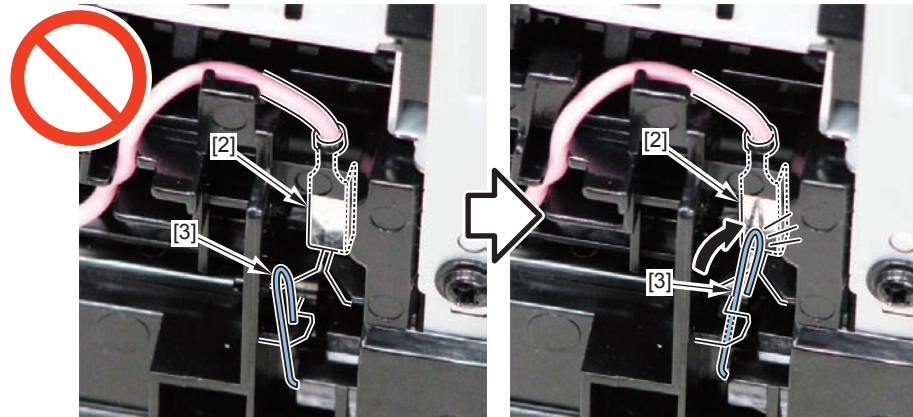

F-4-565

4) Remove the Harness Retaining Spring [1] from the 2 hooks [2].

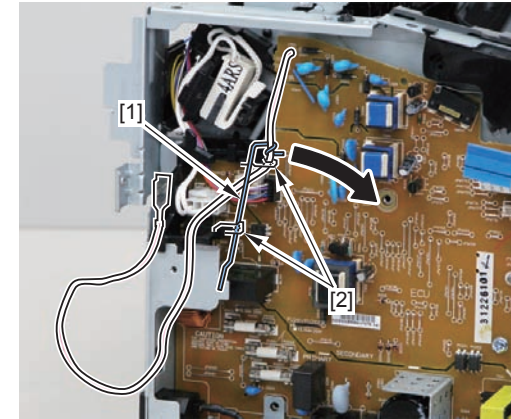

F-4-566

5) Disconnect the 4 connectors [1].

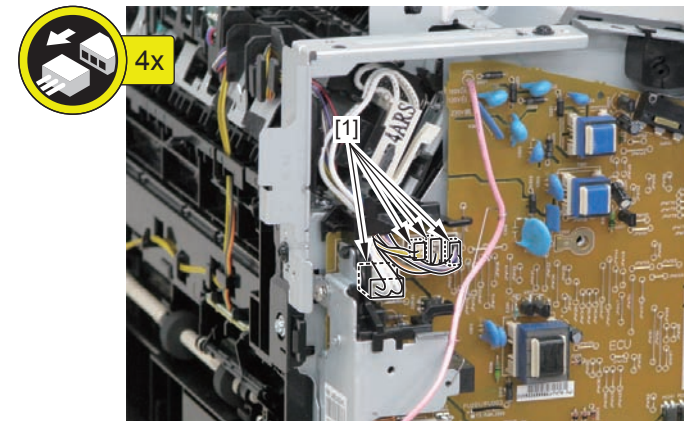

F-4-567

6) Free the Pickup Solenoid Harness [1] from the Harness Guide [A].

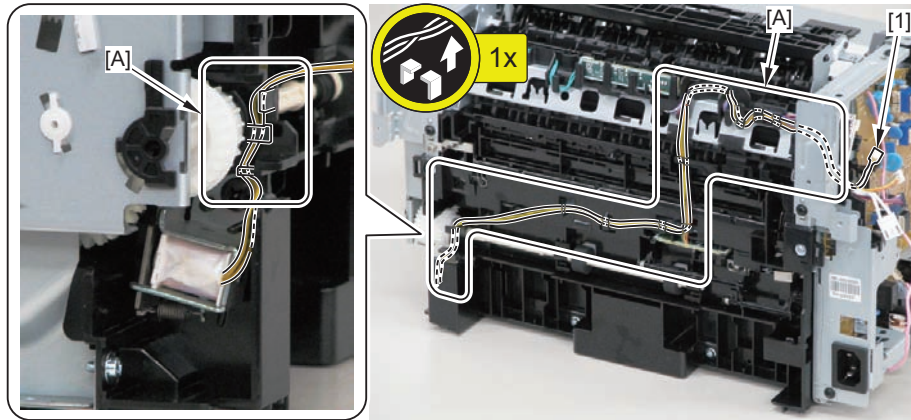

F-4-568

7) Move the Solenoid Arm [1] to remove the Pickup Solenoid [2].

- 1 Screw [3]

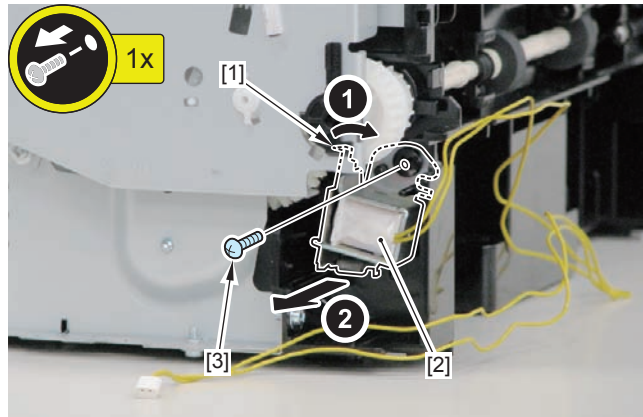

F-4-569

NOTE:

The following shows how to route the harness.

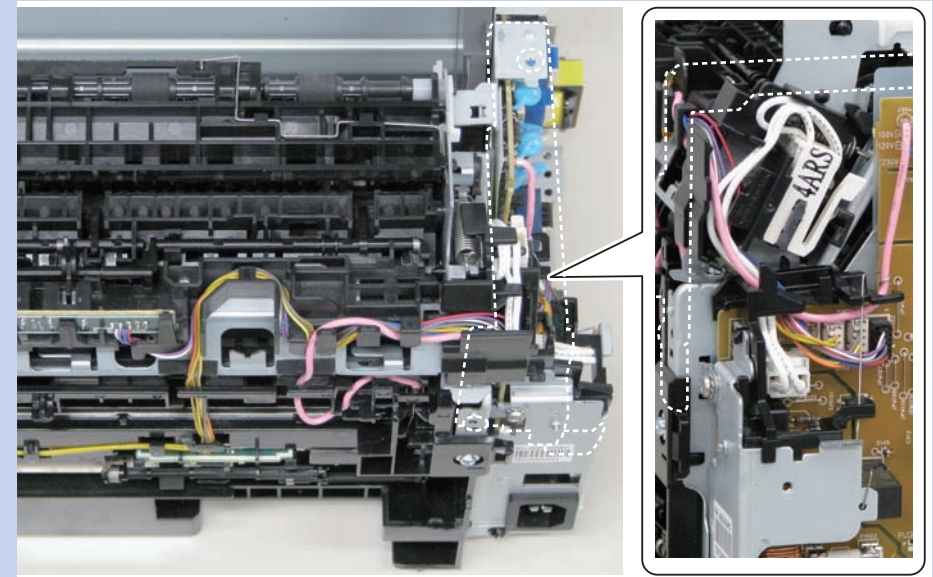

F-4-570



Adjustment

- Mechanical Adjustment

Mechanical Adjustment

Confirming Nip Width

Caution :

Be sure to follow the procedures below, otherwise the fixing film or the fixing sleeve may be damaged.

The nip width of the fixing unit is not adjustable in this printer, however, the incorrect nip width may cause the faulty fixing.

Follow the procedures below to check the nip width.

- 1) Prepare an all-black print of A4 size made by the same type of EP Toner cartridge for this printer before visiting the customer site.
- 2) Load the printed sheet facing DOWN on the pickup tray.
- 3) Print a test-page.
- 4) Turn off the printer when the leading edge of the paper appears in the face-down delivery slot.
Wait for 60 seconds and open the cartridge door to remove the paper from the printer.
- 5) Measure the width of the glossy band across the paper and check if it is meeting the requirements below.

Wasp/Horsethief/Blackrock

- Center (a): 5.5mm to 8.1mm
- Right and left (b, c): 5.5mm to 8.1mm

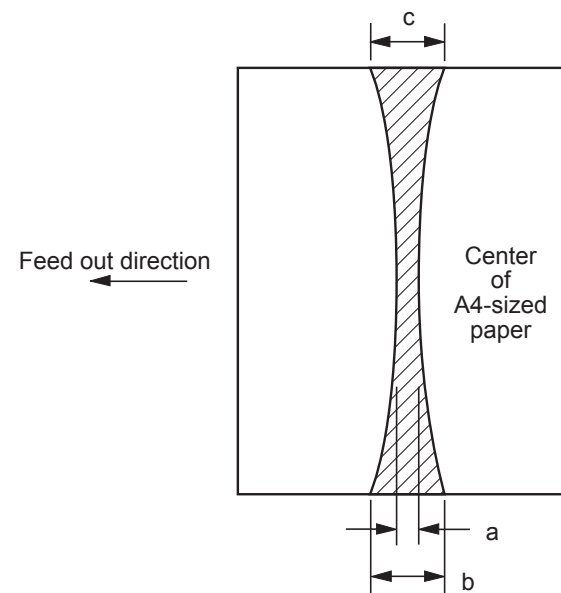

F-5-1

6

Trouble Shooting

- Test Print
- Trouble Shooting Items
- Log Collector
- Version Upgrade

Test Print

Test Print Function

This equipment has a test print function to check if the printer engine normally operates. Test patterns (horizontal lines) are output when executing this test print.

The following is the operation procedure;

a. 1-sided print

- 1) Set A4/LTR papers on the pickup tray or the manual feed pickup tray.
- 2) Continuously open and close the Delivery Tray [1] at least 5 times for odd number of times with the Power Switch ON.
- 3) A 1-sided engine test print is executed.

b. 2-sided print

- 1) Set A4/LTR papers on the pickup tray or the manual feed pickup tray.
- 2) Continuously open and close the Delivery Tray [1] at least 5 times for even number of times with the Power Switch ON.
- 3) A 2-sided engine test print is executed.

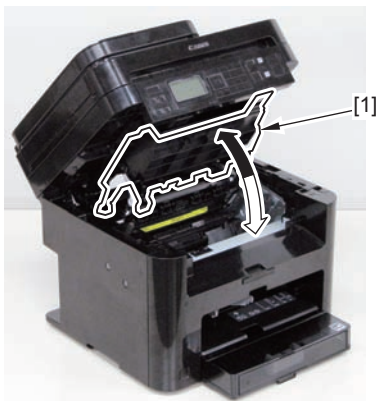

F-6-1

Trouble Shooting Items

Image Faults

Smudged/Streaked

- Bleeding (smear) occurs immediately after the power is turned on for the first time for the day

Description

There is sometimes a case where the difference of temperature between air and inside of the machine causes moisture to occur on the toner immediately after the power is turned on for the first time for the day.

As a result, when the toner transferred on a sheet at the time of initial printing passes through the fixing assembly, moisture on the toner is vaporized into steam, causing bleeding (smear) to occur.

Field Remedy

Prevent bleeding using the following user mode items.

Setting items	Setting value	Description	Additional information
Adjustment/ Maintenance > Special Processing > Special Mode Z	Not used, Mode 1 through 4 (Factory setting: Mode 2)	Make a setting to perform thinning of printed image data by processing of the controller. When the value set for the mode increases, the amount of thinning increases. (The image density decreases.)	Printing time does not increase because the method of image processing performed by the controller is changed. This mode is less effective than Mode B.
Adjustment/ Maintenance > Special Processing > Special Mode B	Not used, Mode 1 through 3 (Factory setting: Not used)	Extend the initial rotation period by processing of the engine. When the value set for the mode increases, the initial rotation period is extended.	The initial rotation period in engine operation is extended, and printing time increases. The initial rotation period for each mode is shown below. Mode 1: 13 sec, Mode 2: 30 sec, Mode 3: 60 sec

T-6-1

Image sample

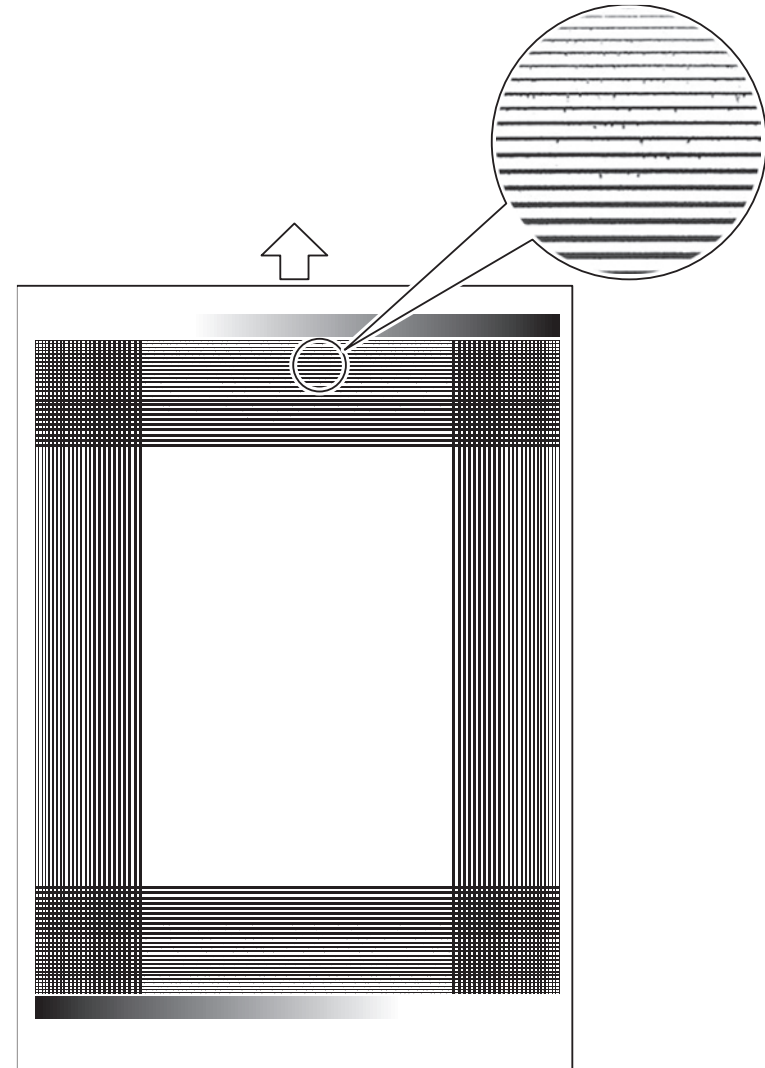

F-6-2

■ Printing Results Are Not Satisfactory

● Smudge Marks Appear on the Edge of Printouts

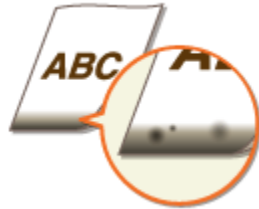

F-6-3

Cause	Solution
Do you print data without margins?	This symptom occurs if a margin is set to none in the printer driver. A margin of 1/4" (5 mm) or less around the edge of paper or 3/8" (10 mm) or less around the edge of envelopes is not printable with the machine. Make sure to have margins around the document to print. <ul style="list-style-type: none"> Setting in the Printer Driver [Finishing] > [Advanced Settings] > [Expand Print Region and Print] > [Off]

T-6-2

● Streaks Appear on Printouts



F-6-4

Cause	Solution
Are you using appropriate paper?	Check usable paper, and replace with appropriate paper.
Did you just replace the toner cartridge? Have you not used the printer for a long period of time?	Change one of the <Special Mode B>, <Special Mode Z>, <Special Mode C>, <Special Mode D> settings. [Menu] > [Adjustment/Maintenance] > [Special Processing]

T-6-3

● White Streaks Appear



F-6-5

Cause	Solution
Is toner running low?	Check how much toner is left, and replace the toner cartridges as necessary.

T-6-4

● Toner Smudges and Splatters Appear



F-6-6

Cause	Solution
Are you using appropriate paper?	Check usable paper, and replace with appropriate paper. Change the setting for <Special Mode U>. [Menu] > [Adjustment/Maintenance] > [Special Processing] > [Special Mode U] > [On]
Is toner running low?	Check how much toner is left, and replace the toner cartridges as necessary.

T-6-5

● Printouts Are Faded



F-6-7

Cause	Solution
Is toner running low?	Check how much toner is left, and replace the toner cartridges as necessary.
Are you using appropriate paper?	Check usable paper, and replace with appropriate paper. Also, specify the paper size and type settings properly.
Are you using the machine in a special environment (in particular, a low-temperature environment)?	Toner may not adhere adequately, causing printouts to appear faded. Change the setting for <Special Mode K>. [Menu] > [Adjustment/Maintenance] > [Special Processing] > [Special Mode K] > [On]

T-6-6

● Printed Pages Have White Specks



F-6-8

Cause	Solution
Are you using appropriate paper?	Check usable paper, and replace with appropriate paper.
Is the drum in the toner cartridge deteriorated?	Replace the toner cartridge with a new one.
Are you printing a document with strong contrasts?	Change the setting for [Special Print Mode] using the Printer Driver. NOTE: When set to [Special Settings 2], print density is lighter compared with [Off] or [Special Settings 1]. Text and lines may also appear faded.

T-6-7

● A Portion of the Page Is Not Printed

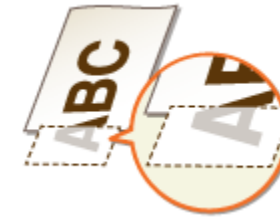

F-6-9

Cause	Solution
Do you print data without margins?	This symptom occurs if a margin is set to none in the printer driver. A margin of 1/4" (5 mm) or less around the edge of paper or 3/8" (10 mm) or less around the edge of envelopes is not printable with the machine. Make sure to have margins around the document to print. • Setting in the Printer Driver [Finishing] > [Advanced Settings] > [Expand Print Region and Print] > [Off]

T-6-8

● Print Density Is Uneven



F-6-10

Cause	Solution
Is toner running low?	Check how much toner is left, and replace the toner cartridges as necessary.
Is printing sometimes uneven when printing fine lines?	Change the setting for <Special Mode J>. [Menu] > [Adjustment/Maintenance] > [Special Processing] > [Special Mode J] > [On]

T-6-9

● Printouts Are Grayish



F-6-11

Cause	Solution
Is <Correct Density> in <Copy Settings> set too dark?	Adjust the setting so that density is lighter.
Is the printer installed where it is subject to direct sunlight or strong light?	Install the printer in an appropriate location.
Was the toner cartridge been left in direct sunlight for a long period of time?	Store the toner cartridge in an appropriate location for two to three hours, then try printing again. This may solve the problem. If the problem persists, replace the toner cartridge.

T-6-10

● Cannot Scan a Printed Barcode



F-6-12

Cause	Solution
Are you trying to scan a barcode printed with factory default settings?	<p>In the printer driver, specify [Special Settings 1] for the setting of [Special Print Mode].</p> <p>NOTE:</p> <ul style="list-style-type: none"> • When set to [Special Settings 1], print density is lighter compared with [Off]. Text and lines may also appear faded. • White specks may appear in images printed on paper other than lightweight paper with this feature set to <ON>.

T-6-11

■ Paper Creases or Curls

● Paper Creases



F-6-13

Cause	Solution
Is paper loaded correctly?	If paper is not loaded below the load limit line or is loaded obliquely, it may crease.
Are you using paper that has absorbed moisture?	Replace with appropriate paper.
Are you using appropriate paper?	<p>Check usable paper, and replace with appropriate paper</p> <p>If the problem persists after using appropriate paper, change the setting for <Special Mode V>.</p> <p>[Menu] > [Adjustment/Maintenance] > [Special Processing] > [Special Mode V] > Select the mode</p>

T-6-12

● Paper Curls



F-6-14

Cause	Solution
Are you using appropriate paper?	<p>Check usable paper, and replace with appropriate paper. Also, specify the paper size and type settings properly.</p> <p>If using Plain (16 to 24 lb Bond (60 to 90 g/m²)), changing [Paper Type] in the printer driver to [Plain L] may solve the problem.</p> <p>If the use of the appropriate paper does not solve the problem, change the setting for <Special Mode V>.</p> <p>[Menu] > [Adjustment/Maintenance] > [Special Processing] > [Special Mode V] > Select the mode</p>

T-6-13

■ Paper Is Fed Incorrectly

● Printouts Are Skewed



F-6-15

Cause	Solution
Do the paper guides align with the edges of the paper?	If the paper guides are too loose or too tight, the printouts are skewed.
Is the paper source the manual feed slot?	Load the paper into the paper drawer.
Are you printing on curled envelopes?	Uncurl the envelopes, and print again.

T-6-14

● Paper Is Not Fed/Two or More Sheets Are Fed Together



F-6-16

Cause	Solution
Is paper loaded correctly?	Fan the paper stack thoroughly so that paper is not stuck together.
	Check whether paper is loaded correctly.
	Check whether the number of sheets of paper loaded is appropriate and whether the appropriate paper is used.
	Check whether mixed sizes and types of paper are loaded together.

T-6-15

● Paper Jams Frequently with 2-Sided Printing (Duplex Model only)



F-6-17

Cause	Solution
Does paper jam frequently especially with lightweight paper or curled paper during 2-sided printing?	Set <Special Mode I> to <On>. [Menu] > [Adjustment/Maintenance] > [Special Processing] > [Special Mode I] > [On]

T-6-16

Log Collector

OutLine

A method to collect the operational status log of the host machine will be provided as a means to analyze failures occurred in the field. When a request was made to the head quarters of the sales company by the CINC division in charge of field follow-up, collect the log by the tool.

Scope of Application

- This function can be used in all the models.
- The tool is supported by Windows XP, Vista, Windows 7, Windows 8 and Windows 8.1.
- Host machine and the PC which operates the tool are connected directly by an USB Cable. Multiple host machines cannot be connected to a PC.

What to Prepare

- Host machine
- USB Cable (Connector shape: A-B)
- PC with a usable USB port (OS: Windows XP, Vista, Windows 7, 8, 8.1)
- Tool (CanonLogCollector_Ver1.0.0.8.zip)*

*Obtain a tool according to instructions of sale company HQ.

Operation Procedure

1. Connecting the USBCable

Connect the USB Cable while both the host machine and the PC are in operation.

2. Decompressing CanonLogCollector_Ver1.0.0.8.zip

Create any folder with a write permission on the PC. When CanonLogCollector_Ver1.0.0.8.zip is decompressed, "CanonLogCollector.exe" is extracted.

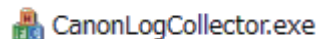

F-6-18

3. Starting the tool

Double-click to start CanonLogCollector.exe. The CanonLogCollector screen opens.

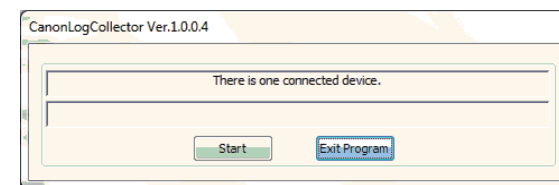

F-6-19

4. Collecting the log

Press the [Start] button on the CanonLogCollector screen. When "Receiving log is successfully finished." is displayed, press the [Exit Program] button to close the tool.

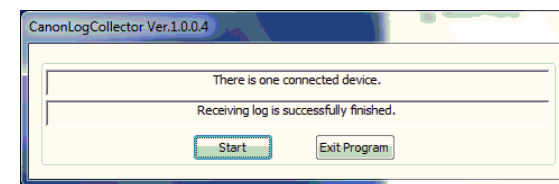

F-6-20

The collected log is generated in TXT format in the folder where "CanonLogCollector.exe" is located. Bring back and send the log to the head quarters of the sales company. The log file is "usb_2011901_132658.log" in the figure below. The capacity of the log file is 300 KB or less. The time needed to collect the log is approx. 10 seconds.

Note:

While the machine is in operation, log information is always added. However, the storage area is limited to 300KB, so the information is overwritten in the order from the old log information. Since log information may be overwritten if a long time passes after error occurrence, be sure to collect log as soon as possible.

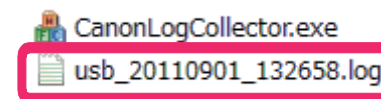

F-6-21

Naming rule for log file:

It is recorded with usb_yyyymmdd_hhmmss.log. yyyymmdd_hhmmss indicates year, month, date, and time (hour, minute, second) when the log is collected.

■ Troubleshooting

The log data is not properly sent from the host machine to the PC when "Receiving log is finished. (Receivetimeout.)" was displayed after the [Start] button was pressed on the CanonLogCollector screen. The size of the log file becomes approx. 1 KB. Collect the log again after setting the USB connection properly. The capacity of the log properly collected becomes 200 KB to 300 KB. Turn OFF and then ON the main power of the host machine when the log cannot be collected even after the USBconnection has been properly set on the PC.

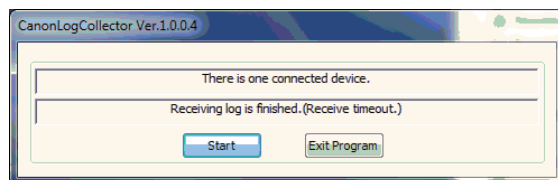

F-6-22

Version Upgrade

Overview

This machine supports the following two methods for upgrading the firmware.

1. User Support Tool (UST)
2. Via Internet

UST

To upgrade versions, use the user support tool (hereinafter UST) and download firmware from a personal computer (hereinafter PC) to this product.

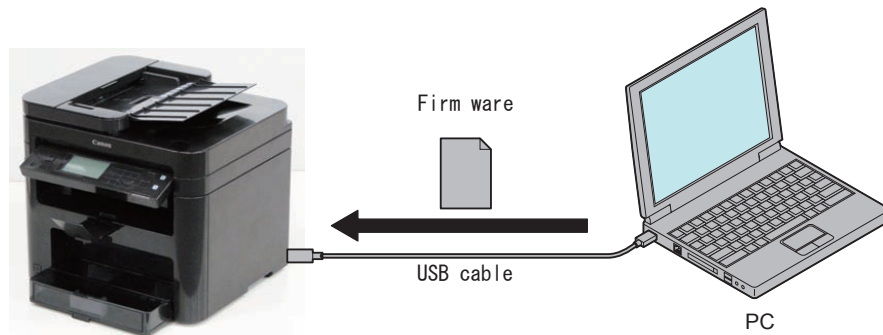

F-6-23

The USB cable uses A(flat type) to B(corner type).

Firmware configuration

Firmware	Function	Stored in
BOOTROM	Start the main controller.	Main controller PCB
BOOTABLE	Control overall performance.	Main controller PCB
LANGUAGE	Manage languages used in panel / Remote UI and font data.	Main controller PCB
DEMO PRINT	Manage data for demo printing.	Main controller PCB
DCON	Control the printer unit.	DC controller PCB

T-6-17

Some UST versions meet less numbers of firmware than those listed above.

Preparation

System Requirements

- OS (one of the following)
 - Microsoft Windows 2000 Server/Professional
 - Microsoft Windows XP Professional/Home Edition
 - Microsoft Windows Server 2003
 - Microsoft Windows Vista*
 - *: Only as for the 32 bit processor version
 - Microsoft Windows Server 2008
(Microsoft Windows 7 to be supported)
 - Microsoft Windows 7
 - Microsoft Windows 8
 - Microsoft Windows 8.1
- PC
 - Compatible to the selected OS
 - Memory (RAM): 32MB or more free space
 - Hard Disk: 100MB or more free space
 - Display: 640x480 pixels or more in resolution, 256 tones or more
 - With USB ports
- UST file for this product*
 - *: Download the corresponding file from the system CD or the service site (ask the service technician in charge for details)
- USB cable (USB A to B)

Preparation

- 1) Start the PC.
- 2) Connect the device to the PC with the USB cable.
- 3) Turn on the device on standby.
- 4) Press [Menu] key to upgrade firmware in User mode.
System Settings > Update Firmware
The message, "Will you restart the device to upgrade firmware?", is shown on the display.
Select Yes.
- 5) Press OK to automatically restart the device. "****DOWNLOAD MODE****" is shown on the display.
- 6) Wait for the motor of the host machine to stop.

Note:
Press STOP key to cancel Download mode and return to the normal operation.

Downloading System Software

- 1) Open UST.



F-6-24

- 2) Take a note of the firmware version to upgrade and click [Next] button.

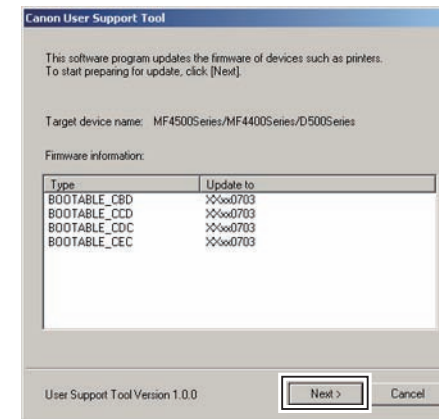

F-6-25

- 3) Click [Next] button.

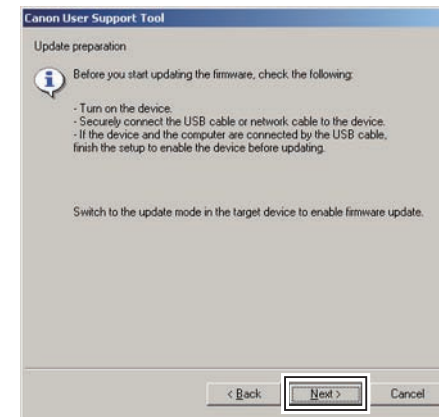

F-6-26

4) Select [USB Device] and click [Next] button.

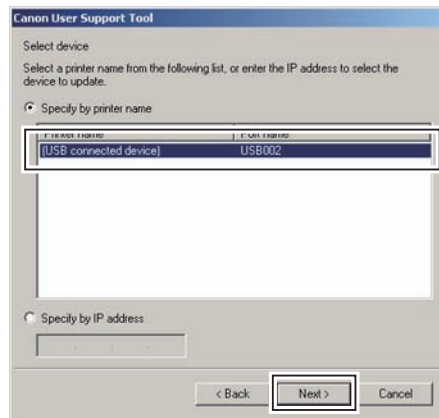

F-6-27

5) Click [Start] button.

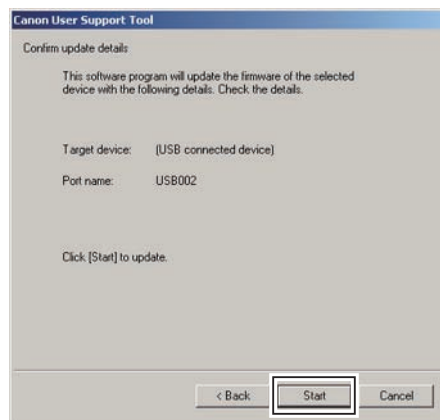

F-6-28

6) Click [Yes] button for the warning message to start download.

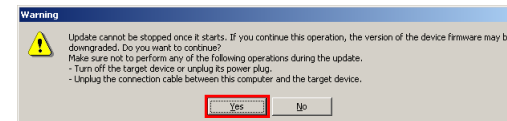

F-6-29



F-6-30

7) Click [OK] button when download is completed.

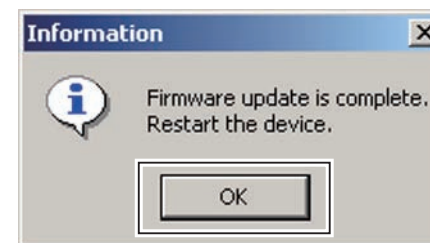

F-6-31

8) Turn off and on the power to restart the device.

9) Output the spec report from Service mode to confirm if the firmware version is the same as that on the note taken in Step 2).

COPIER > FUNCTION > MISC-P > OUTPUT > SPEC

Upgrading via Internet

Overview

The firmware of the host machine can be upgraded via Internet without using PC by selecting "Via Internet" in the operation panel .

Menu > System Management Settings > Update Firmware > Via Internet

MEMO :

- Refer to the User's Manual of the device for how to connect the device to the external network.
- This is applicable either in a wired LAN environment or a wireless LAN environment.

Preparation

- 1) Check that there are no other jobs being executed.
- 2) In an environment where access is obtained via a proxy server, the proxy setting is made from the Remote UI.

Settings/Registration > System Management Settings > Network Settings > TCP/IP Settings > Proxy Settings > Edit... > Use Proxy(select)
Select the [Use Proxy] check box and specify the required settings.

- 3) Check that the serial number of the host machine is shown on the Main Controller PCB.

MEMO :

To upgrade the firmware of the host machine via Internet, the serial number of the machine need to be written on the Main Controller PCB.
Execute COPIER > FUNCTION > MISC-P> SPEC, and check that the BODY No. is registered.
If the BODY No. has not been registered, register the serial number according to "Service Mode > COPIER > OPTION > SERIAL" in "Replacing main controller PCBs".

Messages

The message displayed on the device LUI is as follows.

No.	Error message	The timing of occurrence	Remedy
1	Job in progress... Wait a moment, then try again.	If there is a job being executed:	1. Wait until the job is completed. 2. Cancel the job.
2	Cannot check the firmware version. (Server communication error.)	Network error	1. Check whether the device can be connected to the external network. 2. Check whether the proxy setting has been made (in case of access via a proxy server).
3	Cannot download the firmware. (Error during download.)		1. Check whether the device can be connected to the external network. 2. Check whether the proxy setting has been made (in case of access via a proxy server). 3. Check that the serial number of the host machine is shown on the Main Controller PCB.
4	***DOWNLOAD MODE*** NETWORK AVAILABLE IP ADDRESS IP address of the machine PRESS STOP KEY TO EXIT	If update (writing) of the firmware has ended in failure:	1. Update the firmware again using UST.
5	***DOWNLOAD MODE*** FAILED TO UPDATE		
6	***DOWNLOAD MODE*** UPDATE IS COMPLETE	If the update of the firmware is successful	-

T-6-18



Error Codes

- Overview
- Error Codes
- Jam Codes

Overview

This section describes codes shown in case any problem is occurred.

Since this product does not collect logs for alarms, no alarm code is shown.

Code type	Description	Reference
Error code	This code is displayed when a failure which impacts printing has occurred.	Error Codes
Jam code	This code is displayed when a jam has occurred in this machine.	Jam Codes
Alarm code	N/A	-

T-7-1

Error Codes

Code	Detection description	Remedy
E000	0000	Fixing Assembly does not start up within specified time.
E000	0000	When the same error repeatedly occurs after several times of turning the power OFF/ON, execute the following remedies. (1) Check that the heater resistance measured between 1PIN and 2PIN of the cable (J101) on the DC Controller Board is in the following range. Replace the Fixing Assembly when the resistance value is abnormal. [1] 120 V machine - Heater resistance: $16.0 \Omega \pm 7\%$ [2] 230 V machines - Heater resistance: $53.8 \Omega \pm 7\%$ (2) Check the connection of connector (J101) on the DC Controller Board. (3) Check the connection of connector (J552) on DC Controller Board. (4) Replace the Fixing Assembly. (5) Replace the DC Controller Board.
E001	0000	Abnormal high-temperature detection
E001	0000	When the same error repeatedly occurs after several times of turning the power OFF/ON, execute the following remedies. (1) Check that the heater resistance measured between 1PIN and 2PIN of the cable (J101) on the DC Controller Board is in the following range. Replace the Fixing Assembly when the resistance value is abnormal. [1] 120 V machine - Heater resistance: $16.0 \Omega \pm 7\%$ [2] 230 V machines - Heater resistance: $53.8 \Omega \pm 7\%$ (2) Check the connection of connector (J101) on the DC Controller Board. (3) Check the connection of connector (J552) on DC Controller Board. (4) Replace the Fixing Assembly. (5) Replace the DC Controller Board.
E003	0000	Abnormal low-temperature detection
E003	0000	When the same error repeatedly occurs after several times of turning the power OFF/ON, execute the following remedies. (1) Check that the heater resistance measured between 1PIN and 2PIN of the cable (J101) on the DC Controller Board is in the following range. Replace the Fixing Assembly when the resistance value is abnormal. [1] 120 V machine - Heater resistance: $16.0 \Omega \pm 7\%$ [2] 230 V machines - Heater resistance: $53.8 \Omega \pm 7\%$ (2) Check the connection of connector (J101) on the DC Controller Board. (3) Check the connection of connector (J552) on DC Controller Board. (4) Replace the Fixing Assembly. (5) Replace the DC Controller Board.

Code	Detection description	Remedy
E004	0000	Fixing power supply drive circuit error
E004	0000	When the same error repeatedly occurs after several times of turning the power OFF/ON, execute the following remedies. (1) Replace the DC Controller Board. (2) Replace the Fixing Assembly.
E100	0001	Error detection on any of scanner motor, laser unit, and BD detection at scanner area.
E100	0001	When the same error repeatedly occurs after several times of turning the power OFF/ON, execute the following remedies. (1) Replace the Laser Scanner Unit. (2) Replace the DC Controller Board.
E196	2000	ROM read/write error (Error in storing each setting values for user mode / service mode / factory mode)
E196	2000	When the same error repeatedly occurs after several times of turning the power OFF/ON, execute the following remedies. (1) Update the set of the Controller Firmware (2) Replace the Main Controller Board.
E202	0002	Contact Sensor HP error, Failure in return
E202	0002	When the same error repeatedly occurs after several times of turning the power OFF/ON, execute the following remedies. (1) Check the connection of Flat Cable between Main Controller Board (J5) and Contact Sensor. (2) Replace the Flat Cable between Main Controller Board (J5) and Contact Sensor. (3) Replace the Contact Sensor. (4) Replace the Main Controller Board.
E225	0001	Light intensity of a lamp is less or equal to the criteria
E225	0001	When the same error repeatedly occurs after several times of turning the power OFF/ON, execute the following remedies. (1) Check the connection of Flat Cable between Main Controller Board (J5) and Contact Sensor. (2) Replace the Flat Cable between Main Controller Board (J5) and Contact Sensor. (3) Replace the Contact Sensor. (4) Replace the Main Controller Board.
E301	0001	Insufficient light intensity in shading
E301	0001	When the same error repeatedly occurs after several times of turning the power OFF/ON, execute the following remedies. (1) Check the connection of Flat Cable between Main Controller Board (J5) and Contact Sensor. (2) Replace the Flat Cable between Main Controller Board (J5) and Contact Sensor. (3) Replace the Contact Sensor. (4) Replace the Main Controller Board.

Code		Detection description	Remedy
E736	0000	Communication error with CCU/modem, or no FAX board installed on FAX model.	When the same error repeatedly occurs after several times of turning the power OFF/ON, execute the following remedies. (1) Check the connection of connectors between the Main Controller Board (J601, J602) and the FAX-NCU Board (J1201, J1204). (2) Replace the connectors between the Main Controller Board (J601, J602) and the FAX-NCU Board (J1201, J1204). (3) Replace the FAX-NCU Board. (4) Replace the Main Controller Board.
E740	0002	Error detection on either Network Board or Mac address	When the same error repeatedly occurs after several times of turning the power OFF/ON, execute the following remedies. (1) Check the connection of the network cable. (2) Replace the Main Controller Board.
E744	0002	Language file error	When the same error repeatedly occurs after several times of turning the power OFF/ON, execute the following remedies. Update the set of the Controller Firmware
	4000	Engine ID error (Invalid engine connection is detected)	When the same error repeatedly occurs after several times of turning the power OFF/ON, execute the following remedies. (1) Check the DC Controller Board. (2) Update the Engine Firmware. (3) Update the set of the Controller Firmware
	6000	Communication error with Wireless LAN board.	When the same error repeatedly occurs after several times of turning the power OFF/ON, execute the following remedies. (1) Replace the Wireless LAN Board. (4) Replace the Main Controller Board.
E806	0000	Fan Motor cannot rotate at specified revolution speed.	When the same error repeatedly occurs after several times of turning the power OFF/ON, execute the following remedies. (1) Replace the Main Fan Unit. (2) Replace the DC Controller Board.
E808	0001	Fixing Assembly_Edge Left Cooling Fan error	When the same error repeatedly occurs after several times of turning the power OFF/ON, execute the following remedies. (1) Replace the Edge Left Cooling Fan. (2) Replace the DC Controller Board.
E808	0002	Fixing Assembly_Edge Right Cooling Fan error	When the same error repeatedly occurs after several times of turning the power OFF/ON, execute the following remedies. (1) Replace the Edge Right Cooling Fan. (2) Replace the DC Controller Board.

T-7-2

Jam Codes

Jam Codes	Cause
Scanner Jam Codes	
0001H	Non-DES sensors.
0002H	DES Sensor Stationary
0094H	Initial Stationary
0095H	Pickup NG
0071H	Timing error
Printer Jam Codes	
0004H	Re-pickup Delay Jam
0005H	Multi-purpose tray pickup delay jam
0008H	Pickup Stationary Jam
000CH	Fixing Delivery Delay Jam
0010H	Fixing Delivery Stationary Jam
0014H	Internal Paper Jam
0018H	Door Open Jam
001CH	Wrap Jam
0020H	Reversal Delay Jam
0021H	Reversal Stationary Jam

T-7-3



Service Mode

- Overview
- COPIER
- FEEDER
- FAX
- TESTMODE
- NETWORK

Overview

Entering Service Mode.

Contact the sales company for the method to enter service mode.

Service Mode Menu

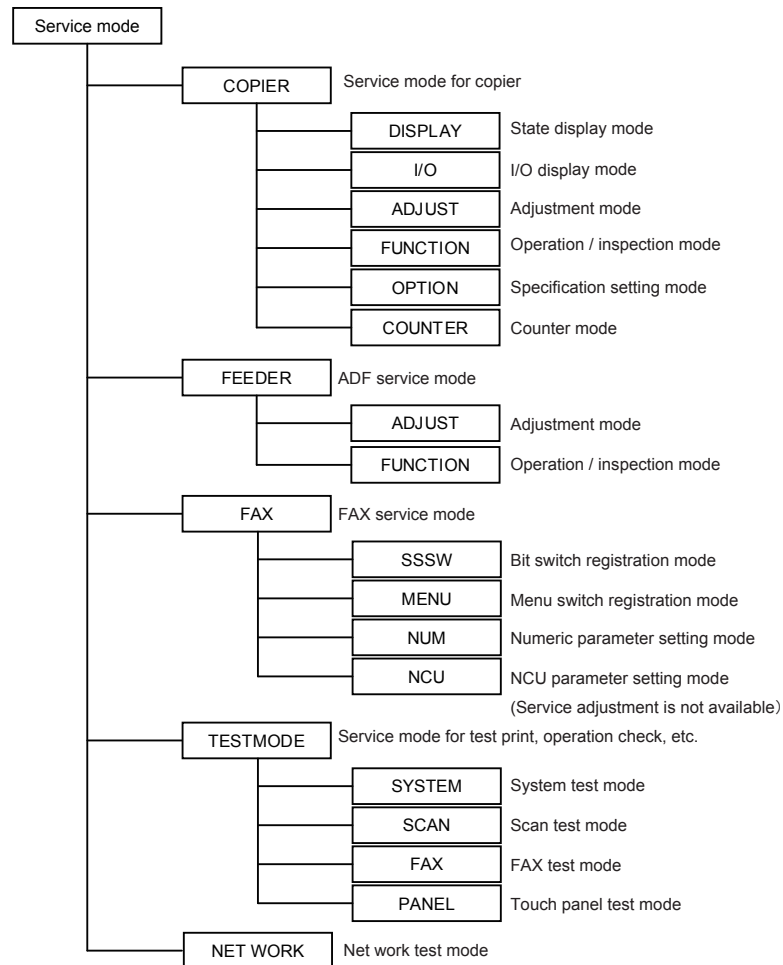

F-8-1

Screen flow of Service mode

	5 Line LCD model	6 Line LCD model
Initial / Category / Sub category screen		
LCD		
Select the item	: Up-arrow / down-arrow key	: Display Touch
Go to Sub category screen	: OK key	: Display Touch
Go to Initial screen	: Return key	: Return key
Item selection screen		
LCD		
Select the item	: Up-arrow / down-arrow key	: Display Touch
Go to Setting screen	: OK key	: Display Touch
Go to Sub category screen	: Return key	: Return key

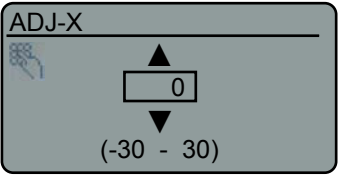
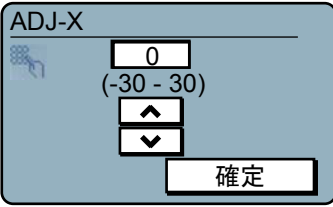
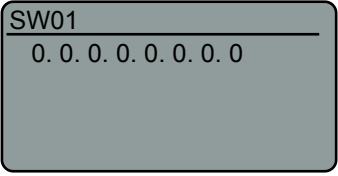
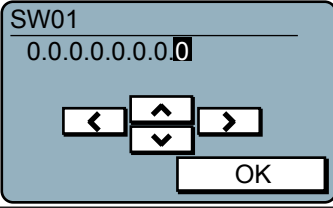
	5 Line LCD model	6 Line LCD model
Input value screen		
LCD		
Enter the setting value	: numeric keypad	: numeric keypad
Increment the setting value one by one	: Up-arrow key	: Up-arrow key
Decrease the setting value one by one	: Down-arrow key	: Down-arrow key
Nullify the setting value	: Clear key	: numeric keypad [0]
Change the setting	: OK key	: Display Touch
Maintain the setting	: Return key	: Return key
How to input the switch setting value		
LCD		
	F-8-2	
Select the bit	: Right/Left-arrow key	: Right/Left-arrow key
Increment the setting value one by one	: Up-arrow key	: Up-arrow key
Decrease the setting value one by one	: Down-arrow key	: Down-arrow key
Change the setting	: OK key	: Display Touch

T-8-1

COPIER

DISPLAY

VERSION

COPIER > DISPLAY > VERSION		
Sub item	Description	Common to all models
MAIN	Display version/checksum of Bootable (Product program area)	Yes
BOOT	Display version/checksum of BootROM (Boot program area)	Yes
LANG	Display version/checksum of Language (Resource area)	Yes
ECONT	Display ROM version of recording engine	Yes

T-8-2

ERR

COPIER > DISPLAY > ERR		
Sub item	Description	Common to all models
ERR	Error code display (for PESP) To display the error code and detail code of the system error. Up to 20 items	Yes

T-8-3

JAM

COPIER > DISPLAY > JAM		
Sub item	Description	Common to all models
ERR	Jam history display (for PESP) To display the jam history of the printer and scanner. Up to 20 items	Yes

T-8-4

CCD

COPIER > DISPLAY > CCD			
Sub item	Description	ADF model	Other
FB-TARGET-B	Shading target value for BLUE of Reader Copyboard	Yes	Yes
FB-TARGET-G	Shading target value for GREEN of Reader Copyboard	Yes	Yes
FB-TARGET-R	Shading target value for RED of Reader Copyboard	Yes	Yes
FB-TARGET-BW	Shading target value of Reader Copyboard in black and white	Yes	Yes
DF-TARGET-B	Shading target value for BLUE of DF	Yes	No
DF-TARGET-G	Shading target value for GREEN of DF	Yes	No
DF-TARGET-R	Shading target value for RED of DF	Yes	No
DF-TARGET-BW	Shading target value of DF in black and white	Yes	No

T-8-5

I/O

R-CON

COPIER > I/O > R-CON				
Address	BIT	Contents of display	ADF model	Other
P001	0	Sensor state display (DES)	Yes	No
	1	Sensor state display (DS)	Yes	No

T-8-6

ADJUST

ADJ-XY

COPIER > ADJUST > ADJ-XY			
Sub item	Description	ADF model	Other
ADJ-X	Adjustment value of image reading start position (Horizontal scanning direction) (X direction) [Applicable case] When the reading position of vertical scanning direction in fixed reading is incorrect [Adjustment] <ul style="list-style-type: none"> Reduce the setting value when non-image width is larger than criteria. Increase the setting value when the area out of original area is copied. When increment the setting value by 1, the image reading start position is moved toward trailing edge by 0.1mm. Setting range: - 30 ~ 30 [Value after RAM clear: 0]	Yes	Yes
STRD-POS	Adjusting reading position in DF stream reading [Applicable case] When the reading position of vertical scanning direction in DF stream reading is incorrect [Adjustment] <ul style="list-style-type: none"> When increment the setting value by 1, image reading start position is moved toward leading edge by 0.1mm. Setting range: - 30 ~ 30 [Value after RAM clear: 0]	Yes	No
ADJ-X-MG	Fine adjustment (0.1% precision) of magnification ratio in Horizontal scanning direction in copyboard reading $\pm 3\%$ [Applicable case] When copy output image is larger or smaller than original image [Adjustment] Adjust by comparing the copy output and original. <ul style="list-style-type: none"> Increase the value when output image is smaller. Decrease the value when output image is larger. Setting range: - 30 ~ 30 [Factory default settings/ Value after RAM clear] 0 [Caution] This adjustment is targeted to adjust the image position on copy output. This may affect to the image of SCAN.	Yes	Yes

T-8-7

■ CCD

COPIER > ADJUST > CCD			
Sub item	Description	ADF model	Other
FBTAR-R	Shading target value for RED in copyboard reading Setting range: 128 ~ 384 [Value after RAM clear: 290]	Yes	Yes
FBTAR-G	Shading target value for GREEN in copyboard reading Setting range: 128 ~ 384 [Value after RAM clear: 284]	Yes	Yes
FBTAR-B	Shading target value for BLUE in copyboard reading Setting range: 128 ~ 384 [Value after RAM clear: 278]	Yes	Yes
FBTAR-BW	Shading target value in copyboard black and white reading Setting range: 128 ~ 384 [Value after RAM clear: 301]	Yes	Yes
DFTAR-R	Shading target value for RED in DF reading Setting range: 128 ~ 384 [Value after RAM clear: 334]	Yes	No
DFTAR-G	Shading target value for GREEN in DF reading Setting range: 128 ~ 384 [Value after RAM clear: 323]	Yes	No
DFTAR-B	Shading target value for BLUE in DF reading Setting range: 128 ~ 384 [Value after RAM clear: 318]	Yes	No
DFTAR-BW	Shading target value in black and white reading Setting range: 128 ~ 384 [Value after RAM clear: 341]	Yes	No

T-8-8

■ TOUCHCHK

COPIER > ADJUST > CCD		
Sub item	Description	Common to all models
CCD	To adjust the coordinate on the Touch Panel.	Yes

T-8-9

FUNCTION

■ CLEAR

COPIER > FUNCTION > CLEAR				
Sub item	Item	Description	FAX model	Other
TEL-USER		Clear the user data and the registered address data. SSSW is not cleared. When this service mode is executed, a message "REBOOTING..." is displayed on the Control Panel, and the host machine is automatically restarted.	Yes	Yes
SRVC-DAT		SERVICE DATA is cleared. User data is not cleared.	Yes	Yes
HIST	ACT-HIST	Communication log is cleared.	Yes	No
	ACC-HIST	Each print log is cleared.	Yes	Yes
	JAM-HIST	JAM log is cleared.	Yes	Yes
	ERR-HIST	Error(E code) log is cleared.	Yes	Yes
PWD-CLEAR		Password of the system administrator is cleared.	Yes	Yes
ALL		The following data are cleared. <ul style="list-style-type: none"> • USER DATA • SERVICE DATA • JOB ID • Each log • CLEAR DATE USER DATA/ SERVICE DATA are reset to the default location value. Appropriate values for LOCAL / SIZE-LC needs to be preset before executing of CLEAR -> ALL When this service mode is executed without setting the appropriate values for LOCAL / SIZE-LC, factory default settings are continued to use. When this service mode is executed, a message "REBOOTING..." is displayed on the Control Panel, and the host machine is automatically restarted.	Yes	Yes

T-8-10

■ MISC-R

COPIER > FUNCTION > MISC-R		
Sub item	Description	Common to all models
SCANLAMP	Execution of lighting function for Scanning Lamp. (CIS LED R -> G -> B -> W -> OFF)	Yes

T-8-11

MISC-P

OUTPUT

When outputting the report, place paper in the Pickup Cassette, and remove paper from the Multi-purpose Tray.

If paper is placed in the Multi-purpose Tray, the report is not output even if paper is placed in the Pickup Cassette.

COPIER > FUNCTION > MISC-P			
Sub item	Description	FAX model	Other
SRVC-DAT	To output the system data list/ system dump list as follows;	Yes	No
SYS-DAT	To output the system data list. Service software switches and parameters used in FAX function are mainly outputted.	Yes	No
SYS-DMP	To output the system dump list. Service data such as the number of communications, the number of receiving pages and sending pages, and the number of error are outputted.	Yes	No
CNTR	To output the counter report. Counter values of use trend for reading, storage, communications, and copy are displayed.	Yes	Yes
SPEC	To output the spec report. Current device status is printed out.	Yes	Yes
KEY-HIST	Output of the key log report To output the key log up to the time the transmission task was input (the [START] key was pressed).	Yes	No

T-8-12

SYSTEM

COPIER > FUNCTION > SYSTEM		
Sub item	Description	Common to all models
DOWNLOAD	To switch to the download mode.	Yes

T-8-13

PARAM

COPIER > FUNCTION > PARAM			
Sub item	Description	FAX model	Other
EXC-NAVI	To switch of installation navigation. Setting value <ul style="list-style-type: none"> • 0: Enable (Default) • 1: Disable Set this switch to 1 after the termination of installation navigation. Installation navigation is not executed when this switch is 1 at next start-up. When this service mode is executed, a message "REBOOTING..." is displayed on the Control Panel, and the host machine is automatically restarted.	Yes	No

T-8-14

■ SPLMAN

COPIER > FUNCTION > SPLMAN			
Sub item	Description	Simplex Model	Duplex Model
TOP-MPT	Adjustment of leading edge margin when feeding from MP tray. Adjustment in: 0.1mm Setting range: 50 ~ 150 (Default value: 100)	Yes	Yes
TOP-DUP-MPT	Adjustment of leading edge margin on both sides/ back side when feeding from MP tray. Adjustment in: 0.1mm Setting range: 50 ~ 150 (Default value: 100)	No	Yes
LEFT-MPT	Adjustment of left margin when feeding from MP tray. Adjustment in: 0.1mm Setting range: 50 ~ 150 (Default value: 91)	Yes	Yes
LEFT-DUP-MPT	Adjustment of left margin on both sides/ back side when feeding from MP tray. Adjustment in: 0.1mm Setting range: 50 ~ 150 (Default value: 92)	No	Yes
TOP-CST	Adjustment of leading edge margin when feeding from cassette. Adjustment in: 0.1mm Setting range: 50 ~ 150 (Default value: 100)	Yes	Yes
TOP-DUP-CST	Adjustment of leading edge margin on both sides/ back side when feeding from cassette. Adjustment in: 0.1mm Setting range: 50 ~ 150 (Default value: 100)	No	Yes
LEFT-CST	Adjustment of left margin when feeding from cassette. Adjustment in: 0.1mm Setting range: 50 ~ 150 (Default value: 91)	Yes	Yes
LEFT-DUP-CST	Adjustment of left margin on both sides/ back side when feeding from cassette. Adjustment in: 0.1mm Setting range: 50 ~ 150 (Default value: 92)	No	Yes

T-8-15

OPTION

■ BODY

COPIER > OPTION > BODY			
Sub item	Description	ADF model	Other
LOCALE	To set country group. 1: Japan 2: North America 3: Korea 4: China 5: Taiwan 6: Europe 7: Asia 8: Oceania Setting range: 1 - 8 (Default value: Factory default) Execute the following service mode to enable this setting. COPIER > FUNCTION > CLEAR > ALL	Yes	Yes
ASLPMAX	To change the maximum value of the auto sleep time. Setting range: 30 or 240 (Default value: 30)	Yes	Yes

T-8-16

■ ACC

COPIER > OPTION > ACC		
Sub item	Description	Common to all models
WLAN	Shows whether the Wireless LAN function is ON/OFF. 0: Forcibly turned OFF (The function is disabled even if the wireless LAN is installed.) 1: ON (default value)	Yes
WLANMODE	Shows whether the Wireless LAN IEEE 802.11n standard is enabled/disabled. 0: Disabled 1: Enabled (Default value)	Yes
WLANSERIAL	Use this setting to use the serial interface exclusively for the WiFi function. Use this setting to take various measurement of Wireless LAN. 0: Normal mode(Default value) 1: Measurement mode	Yes

T-8-17

SERIAL

COPIER > OPTION > SERIAL		
Sub item	Description	Common to all models
SN-MAIN	<p>Enter the device serial number written on the rating name plate of the host machine.</p> <p><Input procedure></p> <ol style="list-style-type: none"> Write down the value in the "Location" field (blank by default) of System Management Settings from remote UI or local UI. -> In the field, the Controller PCB is replaced with a service part. Enter the serial number in "Location" of the system management settings, and confirm the serial number. [Menu] > [System Management Settings] > [Device Information Settings] > [Location] <div style="display: flex; justify-content: space-around;"> <div style="border: 1px solid black; padding: 5px;"> <p>Device Information Settings</p> <p>Device Name</p> <p>Location</p> </div> <div style="border: 1px solid black; padding: 5px;"> <p>Location</p> <p>RUV0021</p> <p>Symbol</p> <p>A/a/12</p> <p>Apply</p> </div> </div> <p style="text-align: right; font-size: small;">F-8-3</p> <ol style="list-style-type: none"> Temporarily enter the serial number in "Location" (8 alphanumeric characters). Execute this service mode. Check that OK is displayed in COPIER > OPTION > SERIAL > SN-MAIN. <div style="display: flex; justify-content: space-around;"> <div style="border: 1px solid black; padding: 5px;"> <p>SN-MAIN</p> </div> <div style="border: 1px solid black; padding: 5px;"> <p>Result : OK</p> </div> </div> <p style="text-align: right; font-size: small;">F-8-4</p> <p>After execution, turn OFF and then ON the power. Perform output only when the entered serial number is 8 alphanumeric characters. After output, the serial number entered in "Location" will be deleted.</p> <ol style="list-style-type: none"> After turning ON the power, check the serial number on the system management data list. Change the setting of "Location" back to the original value. (Enter the value you wrote down in step 1.) 	Yes

T-8-18

COUNTER

TOTAL

COPIER > COUNTER > TOTAL				
Display/ Setting/ Adjustment rage: 0 ~ 999,999 Return to 0 when exceeding 999,999.				
Sub item	Description	Common to all models	FAX model	Duplex Model
SERVICE1	Total counter 1 for service Count up when a paper is ejected from the machine (regardless of sizes such as large size and small size.)	Yes		
SERVICE2	Total counter 2 for service Count up when a paper is ejected from the machine (regardless of sizes such as large size and small size.)	Yes		
TTL	Total counter (Copier + Printer + FAX + Combination)	Yes		
COPY	Total copy counter Count up when a paper is ejected from the machine after execution of copy operation.	Yes		
PDL-PRT	PDL printing counter Count up when PDL printing, ejecting a paper from the machine, and duplex stacking. Blank paper is also counted. Count up by 1 regardless of large or small.	Yes		
FAX-PRT	FAX reception printing counter Count up when FAX reception printing, ejecting a paper from the machine, and duplex stacking. Blank paper is also counted. Count up by 1 regardless of large or small. It can be cleared.		Yes	
RPT-PRT	Report printing counter Count up when report printing, ejecting a paper from the machine, and duplex stacking. Blank paper is also counted. Count up by 1 regardless of large or small. It can be cleared.	Yes		
2-SIDE	2 sided copy/ print counter Count up the number of passing through the duplex path in copying/ printing when ejecting a paper from the machine and duplex stacking. Blank paper is also counted. Count up by 1 regardless of large or small. It can be cleared.			Yes
SCAN	Scanning counter Count up the number of scanning when scanning is completed. Count up by 1 regardless of large or small. It can be cleared.	Yes		

T-8-19

PICK-UP

COPIER > COUNTER > PICK-UP			
Display/ Setting/ Adjustment rage: 0 ~ 999,999 Return to 0 when exceeding 999,999.			
Sub item	Description	Simplex Model	Duplex Model
C1	Total counter of cassette 1 pickup Display the number of pages picked up from cassette 1.	Yes	Yes
MF	Total counter of multi-purpose tray pickup Display the number of pages picked up from multi-purpose tray.	Yes	Yes
2-SIDE	Total counter of 2-sided pickup Display the number of pages by 2-sided pickup.	No	Yes

T-8-20

FEEDER

COPIER > COUNTER > FEEDER			
Display/ Setting/ Adjustment rage: 0 ~ 999,999 Return to 0 when exceeding 999,999.			
Sub item	Description	ADF model	Other
FEED	Total counter of document pickup by ADF	Yes	No

T-8-21

JAM

COPIER > COUNTER > JAM				
Display/ Setting/ Adjustment rage: 0 ~ 999,999 Return to 0 when exceeding 999,999.				
Sub item	Description	Common to all models	ADF model	Duplex Model
TOTAL	Total jam counter	Yes		
FEEDER	Total jam counter for feeder		Yes	
2-SIDE	Jam counter for duplex unit			Yes
MF	Jam counter for multi-purpose tray	Yes		
C1	Jam counter for cassette 1	Yes		

T-8-22

FEEDER

ADJUST

FEEDER > ADJUST			
Sub item	Description	ADF model	Other
DOCST	Adjustment of the page front reading position when using ADF(common in SADF model and DADF model). Setting range: -30 ~ 30	Yes	No
LA-SPD	Adjustment of magnification ratio in vertical scanning direction in stream feeding. 0.1% precision Setting range: -30 ~ 30	Yes	No

T-8-23

FUNCTION

FEEDER > FUNCTION				
Sub item	Description	SADF model	DADF model	Other
FEED-CHK	Paper feeding test for only ADF Setting value 1: SADF 2:DADF	Yes	Yes	No
SL-ON	Operation start-up for solenoid The solenoid is operated only for 100 ms because the solenoid will burn if it is kept ON for a long period of time.	No	Yes	No
MTR-ON	Operation start-up for motor	Yes	Yes	No
FEED-ON	Paper feeding test for only ADF	Yes	Yes	No

T-8-24

FAX

 List of SSSW

- FAX model only

FAX > SSSW		
SSSW No.	Bit No.	Function
SW 01		(Errors, COPY functions)
	Bit 0	Output error codes for service technicians
	Bit 1	Error in memory dump
	Bit 2	Enter the password for transferring received confidential image
	Bit 3	Prohibit COPY
	Bit 4	Display No. 300s
	Bit 5	
	Bit 6	Prohibit users from setting date/time
SW 02		(Setting for network connection criteria)
	Bit 0	Do not start when memory clear list is unable to output
	Bit 1	
	Bit 2	
	Bit 3	
	Bit 4	V34 CCR TN OFF
	Bit 5	
	Bit 6	
SW 03		(Echo measures)
	Bit 0	Check EQM of TCF
	Bit 1	Apply echo protect tone to V.29
	Bit 2	
	Bit 3	
	Bit 4	Heard DIS twice
	Bit 5	First DIS interference
	Bit 6	Interfered DIS frequency
SW 04		(Measures against communication troubles)
	Bit 0	Monitor LC
	Bit 1	Check CI signal frequency
	Bit 2	V21 end flag
	Bit 3	Prohibit T.30 node F kept by both parties
	Bit 4	T.30 node F echo timer
	Bit 5	Check CI signal frequency when setting PBX
	Bit 6	Do not send CNG for manual outgoing transmission
Bit 7	Do not send CED for manual incoming transmission	

FAX > SSSW		
SSSW No.	Bit No.	Function
SW 05		(Standard functions, DIS signal setting)
	Bit 0	
	Bit 1	mm/inch conversion (text mode)
	Bit 2	mm/inch conversion (text and picture / picture mode)
	Bit 3	Prohibit DIS from transmitting bit33 and the followings.
	Bit 4	Declare cut sheets
	Bit 5	Declare LRT/LGL in DIS
	Bit 6	Prohibit ECM outgoing transmission
SW 06		(Setting of reading criteria)
	Bit 0	Move from DES to pre-scan position
	Bit 1	Pre-scan at time other than power-ON
	Bit 2	Restrict document length
	Bit 3	Stamp option
	Bit 4	Reading width 0:A4 1: LTR
	Bit 5	Record memory copy time sharing
	Bit 6	Variable resolution at COPY
Bit 7	Half tone + super fine	
SW 07		Not in use
SW 08		Not in use
SW 09		Not in use
SW 10		Not in use
SW 11		Not in use
SW 12		(Page timer setting)
	Bit 0	1 page timeout (outgoing transmission)
	Bit 1	
	Bit 2	1 page timeout (HT transmission)
	Bit 3	
	Bit 4	1 page timeout (incoming transmission)
	Bit 5	
	Bit 6	
Bit 7	1 page timeout	
SW 13		
	Bit 0	Prohibit relay broadcasting / transfer while receiving relay / transfer
	Bit 1	Response to faulty image while receiving relay / transfer
	Bit 2	Convert mm/inch when transmitting received image
	Bit 3	
	Bit 4	
	Bit 5	
	Bit 6	
Bit 7		

FAX > SSSW		
SSSW No.	Bit No.	Function
SW 14		
	Bit 0	
	Bit 1	Standard paper size type <NADA>COPIER > OPTION > BODY > MODEL-SZ
	Bit 2	Convert inch to mm in both main/vertical scanning directions or only in vertical scanning direction
	Bit 3	Convert inch to mm only for OCR transmission
	Bit 4	Declare resolution for Inch series
	Bit 5	
	Bit 6	
SW 15	Bit 0	
	Bit 1	Polarity memory timing at dial-in
	Bit 2	Receive incoming calls to ND circuit: device circuit
	Bit 3	
	Bit 4	
	Bit 5	
	Bit 6	Detect continuous signals when switching F/T
	Bit 7	
SW 16		Not in use
SW 17		Not in use
SW 18	Bit 0	Detect carrier disconnection between DCS and TCF
	Bit 1	Waiting time for carrier disconnection between DCS and TCF
	Bit 2	Prohibit communication control for IP network
	Bit 3	
	Bit 4	
	Bit 5	
	Bit 6	
	Bit 7	
SW 19		Not in use
SW 20		Not in use
SW 21		Not in use
SW 22	Bit 0	Prohibit NSX transmission
	Bit 1	Prohibit separated A4 record
	Bit 2	Prohibit broadcasting transmission
	Bit 3	Prohibit manual polling actions
	Bit 4	Prohibit manual transmission when transmitting archives
	Bit 5	
	Bit 6	With archive transmission function
	Bit 7	
SW 23		Not in use

FAX > SSSW		
SSSW No.	Bit No.	Function
SW 24		Not in use
SW 25		(Setting for report display function)
	Bit 0	Prioritize the received telephone number to the dialed number
	Bit 1	Prioritize the received abbreviated name to the dialed abbreviated name
	Bit 2	Regard a received blank CIS as an unreceived CIS
	Bit 3	Message language selection for user SW
	Bit 4	
	Bit 5	
	Bit 6	
SW 26		Not in use
SW 27		Not in use
SW 28	Bit 0	Prohibit calling party for V8 procedure
	Bit 1	Prohibit called party from V8 procedure
	Bit 2	Prohibit calling party from V8 late-start
	Bit 3	Prohibit called party from V8 late-start
	Bit 4	Prohibit V.34 called party from starting fallback
	Bit 5	Prohibit V.34 calling party from starting fallback
	Bit 6	
	Bit 7	
SW 29		Not in use
SW 30	Bit 0	Support for 1284 device ID
	Bit 1	
	Bit 2	
	Bit 3	
	Bit 4	
	Bit 5	New dial tone detection method
	Bit 6	
	Bit 7	
SW 31		Not in use
SW 32	Bit 0	Canon/NTT NSX switching SW
	Bit 1	
	Bit 2	
	Bit 3	
	Bit 4	
	Bit 5	0:NCU2004 1:NCU2002
	Bit 6	
	Bit 7	
SW 33		Not in use
SW 34		Not in use

FAX > SSSW		
SSSW No.	Bit No.	Function
SW 35		Not in use
SW 36		Not in use
SW 37		Not in use
SW 38		Not in use
SW 39		Not in use
SW 40		Not in use
SW 41		Not in use
SW 42		Not in use
SW 43		Not in use
SW 44		Not in use
SW 45		Not in use
SW 46		Not in use
SW 47		Not in use
SW 48		Not in use
SW 49		Not in use
SW 50		Not in use

T-8-25

List of MENU

- FAX model only

Menu switch registration mode		
No.	Parameter	Selection
001	Not in use	
002	Not in use	
003	Not in use	
004	Not in use	
005	ON/OFF of NL equalizer	0: OFF 1: ON
006	Telephone line monitor	0-3 0: DIAL 1: SERVICEMAN 1 2: SERVICEMAN 2 3: OFF
007	Transmission level (ATT)	0-15
008	Upper limit of V.34 modulation speed	0-5 0: 3429BAUD 1: 3200BAUD 2: 3000BAUD 3: 2800BAUD 4: 2743BAUD 5: 2400BAUD
009	Upper limit of V.34 data speed	0-13 0: 33.6kbps 1: 31.2 2: 28.8 3: 26.4 4: 24.0 5: 21.6 6: 19.2 7: 16.8 8: 14.4 9: 12.0 10: 9.6 11: 7.2 12: 4.8 13: 2.4
010	Pseudo-CI signal frequency	0-2 0: 50Hz 1: 25Hz 2: 17Hz
011	Not in use	
012	Not in use	
013	Not in use	
014	Not in use	
015	Not in use	

Menu switch registration mode		
No.	Parameter	Selection
016	Not in use	
017	Not in use	
018	Not in use	
019	Not in use	
020	Not in use	

T-8-26

List of NUM

- FAX model only

Numeric parameter setting mode		
No.	Parameter	Allowable setting range
001	Not in use	
002	RTN transmission criteria X	1 to 99%
003	RTN transmission criteria n	2 to 99 times
004	RTN transmission criteria m	1 to 99 lines
005	NCC pause (before ID code)	1 to 60s
006	NCC pause (after ID code)	1 to 60s
007	Not in use	
008	Not in use	
009	Not in use	
010	T.30 T0 timer	55s principally
011	T.30 T1 timer (for incoming transmission)	0 to 9999 (France=3500, Others=3000)
012	Maximum incoming lines	0 to 65535 (line) 0: without limitation
013	T.30 EOL timer	500 to 3000 (set to 55s by default)
014	Not in use	
015	Threshold between hooking and on-hook	0 to 999
016	Lead time to the first response when switching between FAX and TEL	0 to 9
017	Duration to activate pseudo-RBT cadence	0 to 999
018	Duration to deactivate pseudo-RBT cadence (short)	0 to 999
019	Duration to deactivate pseudo-RBT cadence (long)	0 to 999
020	Duration to activate pseudo-ring cadence	0 to 999
021	Duration to deactivate pseudo-CI cadence (short)	0 to 999
022	Duration to deactivate pseudo-CI cadence (long)	0 to 999
023	CNG detection level when switching between FAX and TEL	0 to 7
024	Pseudo-RBT outgoing level when switching between FAX and TEL	10 to 20 (100v), 0 to 20 (120, 230v)
025	CNG monitor duration while the answering device is activated	0 to 999
026	No signal detection level while the answering device is activated	0 to 7
027	Duration to detect preamble of V21 low-speed flag	20 (*10ms)
028	Not in use	
029	Not in use	
030	Not in use	
031	Not in use	
032	Not in use	
033	Not in use	
034	Not in use	
035	Not in use	

Numeric parameter setting mode		
No.	Parameter	Allowable setting range
036	Not in use	
037	Not in use	
038	Not in use	
039	Not in use	
040	Not in use	
041	Not in use	
042	Not in use	
043	Not in use	
044	Not in use	
045	Not in use	
046	Not in use	
047	Not in use	
048	Not in use	
049	Not in use	
050	Not in use	
051	Threshold to detect hook	10 to 9999
052	Not in use	
053	Set DTMF calling counts when receiving FAX remotely	0 to 9999(*25)
054	Set BusyTone outgoing duration when using handset	0 to 9999
055	Not in use	
056	Not in use	
057	Not in use	
058	Not in use	
059	Not in use	
060	Not in use	
061	Not in use	
062	Not in use	
063	Not in use	
064	Not in use	
065	Not in use	
066	Not in use	
067	Not in use	
068	Not in use	
069	Not in use	
070	Not in use	
071	Not in use	
072	Not in use	
073	Not in use	
078	Exclusive use of a developer	
079	Exclusive use of a developer	
080	Exclusive use of a developer	

T-8-27

List of NCU

- FAX model only

TONE

- Setting of Tone Parameters

While "#NCU" is displayed, press "OK" key -> Select "#TONE" and press "OK" key so that it becomes tone parameter setting mode.

Item	Function	Setting range
001	Tone signal sending time (PSTN)	10 to 9999 (ms)
002	Minimum pause time (PSTN)	10 to 9999 (ms)

TONE/PULSE

T-8-28

PULSE

- Setting of Pulse Parameters

While "#NCU" is displayed, press "OK" key -> Select "#PULSE" and press "OK" key so that it becomes pulse parameter setting mode.

Item	Function	Setting range
FORM	Pulse digit format	0 -> DP (N)
		1 -> DP (N+1)
		2 -> DP (10-N)
001	Pulse dial speed (10pps)	5 to 300 (x0.1pps)
002	Pulse dial speed (20pps)	5 to 300 (x0.1pps)
003	Pulse dial make ratio	10 to 90 (%)
004	Minimum pause time	10 to 9999 (ms)

T-8-29

DIAL TONE

1)Bit switch

Bit No.	Function	1	0
Bit 0	Frequency detection method	Modem	Tonal counter
Bit 1			
Bit 2	Signal frequency	Changed	Not changed
Bit 3			
Bit 4	Judgment of intermittent signal	Start from valid ON signal	Start from either valid ON signal or OFF signal
Bit 5			
Bit 6	Signal form	Continuous	Intermittent
Bit 7	Signal detection	Detected	Not detected

T-8-30

2) Numeric value parameter

Parameter No.	Function	Setting range
001	T0 timer	0 to 9999 (x10ms)
002	T1 timer	0 to 9999 (x10ms)
003	T2 timer	0 to 9999 (x10ms)
004	T3 timer	0 to 9999 (x10ms)
005	T4 timer	0 to 9999 (x10ms)
006	Signal detection table	0 to 16
007	Signal detection level	0 to 7
008	Number of valid tone detection	0 to 9999 (times)

T-8-31

■ 2nd DLTN

1) Bit switch

Bit No.	Function	1	0
Bit 0	Frequency detection method	Modem	Tonal counter
Bit 1			
Bit 2	Signal frequency	Changed	Not changed
Bit 3			
Bit 4	Judgment of intermittent signal	Start from valid ON signal	Start from either valid ON signal or OFF signal
Bit 5			
Bit 6	Signal form	Continuous	Intermittent
Bit 7	Signal detection	Detected	Not detected

T-8-32

2) Numeric value parameter

Parameter No.	Function	Setting range
001	T0 timer	0 to 9999 (x10ms)
002	T1 timer	0 to 9999 (x10ms)
003	T2 timer	0 to 9999 (x10ms)
004	T3 timer	0 to 9999 (x10ms)
005	T4 timer	0 to 9999 (x10ms)
006	Signal detection table	0 to 16
007	Signal detection level	0 to 7
008	Number of valid tone detection	0 to 9999 (times)

T-8-33

■ BUSTONE0

1) Bit switch

Bit No.	Function	1	0
Bit 0			
Bit 1			
Bit 2	Signal frequency	Changed	Not changed
Bit 3			
Bit 4	Judgment of intermittent signal	Start from valid ON signal	Start from either valid ON signal or OFF signal
Bit 5			
Bit 6	Signal form	Continuous	Intermittent
Bit 7	Signal detection	Detected	Not detected

T-8-34

2) Numeric value parameter

Parameter No.	Function	Setting range
001		
002	T1 timer	0 to 9999 (x10ms)
003	T2 timer	0 to 9999 (x10ms)
004	T3 timer	0 to 9999 (x10ms)
005	T4 timer	0 to 9999 (x10ms)
006	Signal detection table	0 to 16
007	Signal detection level	0 to 7
008	Number of valid tone detection	0 to 9999 (times)

T-8-35

■ BUSTONE1

1) Bit switch

Bit No.	Function	1	0
Bit 0			
Bit 1			
Bit 2	Signal frequency	Changed	Not changed
Bit 3	RBT signal detection	Detected	Not detected
Bit 4	Judgment of intermittent signal	Start from valid ON signal	Start from either valid ON signal or OFF signal
Bit 5	RBT signal check cycle	1 cycle	1/2 cycle
Bit 6	Signal form	Continuous	Intermittent
Bit 7	Signal detection	Detected	Not detected

T-8-36

2) Numeric value parameter

Parameter No.	Function	Setting range
001		
002	T1 timer	0 to 9999 (x10ms)
003	T2 timer	0 to 9999 (x10ms)
004	T3 timer	0 to 9999 (x10ms)
005	T4 timer	0 to 9999 (x10ms)
006	Signal detection table	0 to 16
007	Signal detection level	0 to 7
008	Number of valid tone detection	0 to 9999 (times)

T-8-37

REORDRTN

1) Bit switch

Bit No.	Function	1	0
Bit 0			
Bit 1	Signal detection method	FED	FR3
Bit 2	Signal frequency	Changed	Not changed
Bit 3			
Bit 4	Judgment of intermittent signal	Start from valid ON signal	Start from either valid ON signal or OFF signal
Bit 5			
Bit 6	Signal form	Continuous	Intermittent
Bit 7	Signal detection	Detected	Not detected

T-8-38

2) Numeric value parameter

Parameter No.	Function	Setting range
001		
002	T1 timer	0 to 9999 (x10ms)
003	T2 timer	0 to 9999 (x10ms)
004	T3 timer	0 to 9999 (x10ms)
005	T4 timer	0 to 9999 (x10ms)
006	Signal detection table	0 to 16
007	Signal detection level	0 to 7
008	Number of valid tone detection	0 to 9999 (times)

T-8-39

MULTI

1) Numeric value parameter

Parameter No.	Function	Setting range
001		0 to 9999
002		0 to 9999
003		0 to 9999
004		0 to 9999

T-8-40

AUTO RX

1) Numeric value parameter

Parameter No.	Function	Setting range
001	CI ON time	0 to 9999 (x10ms)
002	CI long off time	0 to 9999 (x10ms)
003	CI off time	0 to 9999 (x10ms)
004	CL long off time	0 to 9999 (x10ms)
005	CI MAX off time	0 to 9999 (x10ms)
006	CI wait time	0 to 9999 (x10ms)
007	CI frequency	0 to 9999 (cycle)
008	CI frequency lower limit	0 to 9999 (Hz)
009	CI frequency upper limit	0 to 9999 (Hz)

T-8-41

CNGDTCT

1) Numeric value parameter

Parameter No.	Function	Setting range	
001	At F/T switching	CNG MIN ON time	0 to 9999 (x10ms)
002		CNG MAX ON time	0 to 9999 (x10ms)
003			
004			
005			
006		Hit ratio	0 to 9999 (%)
007	At direct connecting to answering phone	CNG MIN ON time	0 to 9999 (x10ms)
008		CNG MAX ON time	0 to 9999 (x10ms)
009		Tolerable time of instantaneous interruption	0 to 9999 (x10ms)
010			
011		Number of detection	0 to 9999 (Times)
012		Hit ratio	0 to 9999 (%)

T-8-42

SPECIALB

- Not in use

SPECIALN

- Not in use

RKEY

1) Numeric value parameter

Parameter No.	Function	Setting range
001	Connection time of flash	0 to 9999 (x10ms)
002	Connection time of grounding wire	0 to 9999 (x10ms)
003		

T-8-43

PBXDIALT

1) Bit switch

Bit No.	Function	1	0
Bit 0	Frequency detection method	Modem	Tonal counter
Bit 1			
Bit 2	Signal frequency	Changed	Not changed
Bit 3			
Bit 4	Judgment of intermittent signal	Start from valid ON signal	Start from either valid ON signal or OFF signal
Bit 5			
Bit 6	Signal form	Continuous	Intermittent
Bit 7	Signal detection	Detected	Not detected

T-8-44

2) Numeric value parameter

Parameter No.	Function	Setting range
001	T0 timer	0 to 9999 (x10ms)
002	T1 timer	0 to 9999 (x10ms)
003	T2 timer	0 to 9999 (x10ms)
004	T3 timer	0 to 9999 (x10ms)
005	T4 timer	0 to 9999 (x10ms)
006	Signal detection table	0 to 16
007	Signal detection level	0 to 9
008	Number of valid tone detection	0 to 9999 (times)

T-8-45

PBXBUSYT

1) Bit switch

Bit No.	Function	1	0
Bit 0			
Bit 1			
Bit 2	Signal frequency	Changed	Not changed
Bit 3			
Bit 4	Judgment of intermittent signal	Start from valid ON signal	Start from either valid ON signal or OFF signal
Bit 5			
Bit 6	Signal form	Continuous	Intermittent
Bit 7	Signal detection	Detected	Not detected

T-8-46

2) Numeric value parameter

Parameter No.	Function	Setting range
001	-	-
002	T1 timer	0 to 9999 (x10ms)
003	T2 timer	0 to 9999 (x10ms)
004	T3 timer	0 to 9999 (x10ms)
005	T4 timer	0 to 9999 (x10ms)
006	Signal detection table	0 to 16
007	Signal detection level	0 to 9
008	Number of valid tone detection	0 to 9999 (times)

T-8-47

TESTMODE

SYSTEM

DRAM

TESTMODE > SYSTEM > DRAM		
Sub item	Description	Common to all models
TEST1	Data read/write check for DRAM (except system work area)	Yes

T-8-48

SPEAKER

TESTMODE > SYSTEM > SPEAKER			
Sub item	Description	FAX model	Other model
ON	When "ON" is selected, entry tone is generated once.	Yes	No
MIN	When "MIN" is selected, entry tone is generated once.	Yes	No
MAX	When "MAX" is selected, entry tone is generated once.	Yes	No

T-8-49

SCAN

ADJUST

ADF-ADJ

TESTMODE > SCAN > ADJUST > ADF-ADJ			
Sub item	Description	ADF model	Other model
DF-SPEED	Enter the adjustment value for the magnification ratio in vertical scanning direction in stream feeding Setting value: -30 ~ 30(Default value: 0)	Yes	No
DF-OFFSET	Enter for the adjustment of DF original stop position Setting value: -30 ~ 30(Default value: 0)	Yes	No

T-8-50

SENSOR

TESTMODE > SCAN > ADJUST > SENSOR		
Sub item	Description	Common to all models
TRAY PAPER SENSOR	Display the status of Multi Pickup Sensor 1: Paper existing 0: No paper	Yes
REGI SENS	Display the status of Leading Edge Sensor 1: Paper existing 0: No paper	Yes
ESS DOOR SENS	Display the status of Delivery Tray Open/ Close Switch 1: OPEN 0: CLOSE	Yes

T-8-51

ADFTTEST

TESTMODE > SCAN > ADFTTEST				
Sub item	Description	SADF model	DADF model	Other model
SPEED	For testing of ADF feeding speed. Execute feeding test of ADF motor at specified speed. [Setting value] STDFAX, FINEFAX, SFINEFAX, RGB300dpi, RGB150dpi, Gray300dpi, Gray150dpi, Mono300dpi, Mono150dpi	Yes	Yes	No
2-SIDE	Specify ON/OFF for duplex mode	No	Yes	No
COUNT	Page counter for originals: Existing	Yes	Yes	No
START	Start feeding	Yes	Yes	No

T-8-52

BOOKFEED

TESTMODE > SCAN > BOOKFEED		
Sub item	Description	Common to all models
PAGE	Display the number of bookfeed pages	Yes
SPEED	For testing of feeding speed. Execute feeding test of the book motor at specified speed. [Setting value] STDFAX, FINEFAX, SFINEFAX, RGB600dpi, RGB300dpi, RGB150dpi, Gray600dpi, Gray300dpi, Gray150dpi, Mono600dpi, Mono300dpi, Mono150dpi	Yes
START	Start of bookfeed	Yes
STOP	End of bookfeed	Yes

T-8-53



MODEM

TESTMODE > FAX > MODEM			
Sub item	Description	FAX model	Other model
RELAY-1	Test ON/OFF of port SW and relay on NCU Setting value: ON, OFF	Yes	No
FREQ	Transmit selected frequency in closed DC circuit using tone generation function of modem. [Setting values] 462Hz, 1100Hz, 1300Hz, 1500Hz, 1650Hz, 1850Hz, 2100Hz	Yes	No
G3TX	Transmit selected signal pattern in closed DC circuit at selected frequency using G3 signal transmission function of modem. [Setting values] 300bps, 2400bps, 4800bps, 7200bps, 9600bps, TC7200, TC9600, 12000bp, 14400bp	Yes	No
DTMFTX	Transmit DTMF signal using DTMF transmission function of modem after DC circuit closure.	Yes	No
V34G3TX	Transmit selected frequency using G3 signal transmission function (V.34) after DC circuit closure. [Setting values] SPEED : 2400bps*, 3429baud, 3200baud, 3000baud, 2800baud, 2743baud, 2400baud *: 2400bps, 4800bps, 7200bps, 9600bps, 12000bps, 14400bps, 16800bps, 19200bps, 21600bps, 24000bps, 26400bps, 28800bps, 31200bps, 33600bps	Yes	No

T-8-54

■ FACULTY

TESTMODE > FAX > FACULTY			
Sub item	Description	FAX model	Other model
G34800TX	Transmit the frequency of 4800bps using G3 signal transmission function after DC circuit closure.	Yes	No
DETECT1	Ring detection Check the status (ON, OFF) of hook and Ci, Fc from i line.	Yes	No
DETECT2	CNG detection test 1 Execute CNG signal check and FED check. Detect CNG after CML relay is ON.	Yes	No
DETECT3	CNG detection test 2 Execute CNG signal check and FED check. Detect CNG after CML relay is OFF.	Yes	No

T-8-55

● PANEL

TESTMODE > FAX > PANEL		
Sub item	Description	Common to all models
KEY CHECK START	Key check [Applicable case] Check if all keys functions normally after replacement of Control Panel.	Yes
LED CHECK START	LED check [Applicable case] Check if all LEDs are lit normally after replacement of Control Panel.	Yes
LCD CHECK START	LCD check [Applicable case] Check if LCD can display without any missing dot after replacement of Control Panel.	Yes
TOUCH CHECK START	Touch Panel check [Use case] To check if the Touch Panel can be used when replacing the Control Panel	Yes

T-8-56

NETWORK



- Common to all models

NETWORK > SSSW			
Sub item	BIT	Description	
SW01		Not in use	
SW02			
SW03			
SW04			
SW05			
SW06			
SW07			
SW08			
SW09			
SW10 Network Config System	0	Turn ON(Enable)/ OFF(Disable) for acquisition of host name (Option 12) by DHCP Default value: 0	
	1		
	2		
	3		
	4		Turn ON(Enable)/ OFF(Disable) for registration of host name (Option 81) by DHCP Default value: 1
	5		
	6		
	7	Not in use	
SW11		Not in use	
SW12			
SW13			
SW14			
SW15			
SW16			

T-8-57

Appendix

- Service Tools
- Solvent/Oil List
- General Circuit Diagram (Duplex Model)
- General Circuit Diagram (Simplex Model)
- General Timing Chart
- List of User Mode
- Backup Data

Service Tools

The followings are the required tools to perform the service operation.

No.	Tool name	Tool number	Usage/remarks
1	Tool case	TKN-0001	
2	Jumper wire	TKN-0069	With clip
3	Gap gauge	CK-0057	0.02 to 0.03mm
4	Spring scale	CK-0058	To check cassette spring pressure
5	Philips screwdriver	CK-0101	M4, M5 Length: 363mm
6	Philips screwdriver	CK-0104	M3, M4 Length: 155mm
7	Philips screwdriver	CK-0105	M4, M5 Length: 191mm
8	Philips screwdriver	CK-0106	M4, M5 Length: 85mm
9	Flat-blade screwdriver	CK-0111	
10	Precision slot head screwdriver	CK-0114	6 pieces set
11	Hex-key wrench set	CK-0151	5 pieces set
12	Smooth file	CK-0161	
13	Hex screwdriver	CK-0170	M4, Length: 107mm
14	Nipper	CK-0201	
15	Long-nose pliers	CK-0202	
16	Pliers	CK-0203	
17	Stop-ring pliers	CK-0205	For shaft ring
18	Crimping tool	CK-0218	
19	Tweezers	CK-0302	
20	Scale	CK-0303	150mm For measurement
21	Plastic hammer	CK-0314	
22	Brush	CK-0315	
23	Penlight	CK-0327	
24	Plastic bottle	CK-0328	
25	Lint-free paper	CK-0336	500SH/PKG
26	Oiler	CK-0349	30cm ³
27	Plastic bottle	CK-0351	30cm ³
28	Digital multi-meter	FY9-2032	

T-9-1

Solvent/Oil List

Name	Usage	Remarks
Ethyl alcohol	Cleaning e.g.) Metal parts Grease Toner contamination	<ul style="list-style-type: none">• Local procurement• Keep fire away
Lubricant	<ul style="list-style-type: none">• Apply it on gears etc.• Apply it on shafts and shaft supports etc.	<ul style="list-style-type: none">• tool number: HY9-0007 (Dow Corning made Molykote EM-50L)

T-9-2

General Circuit Diagram (Duplex Model)

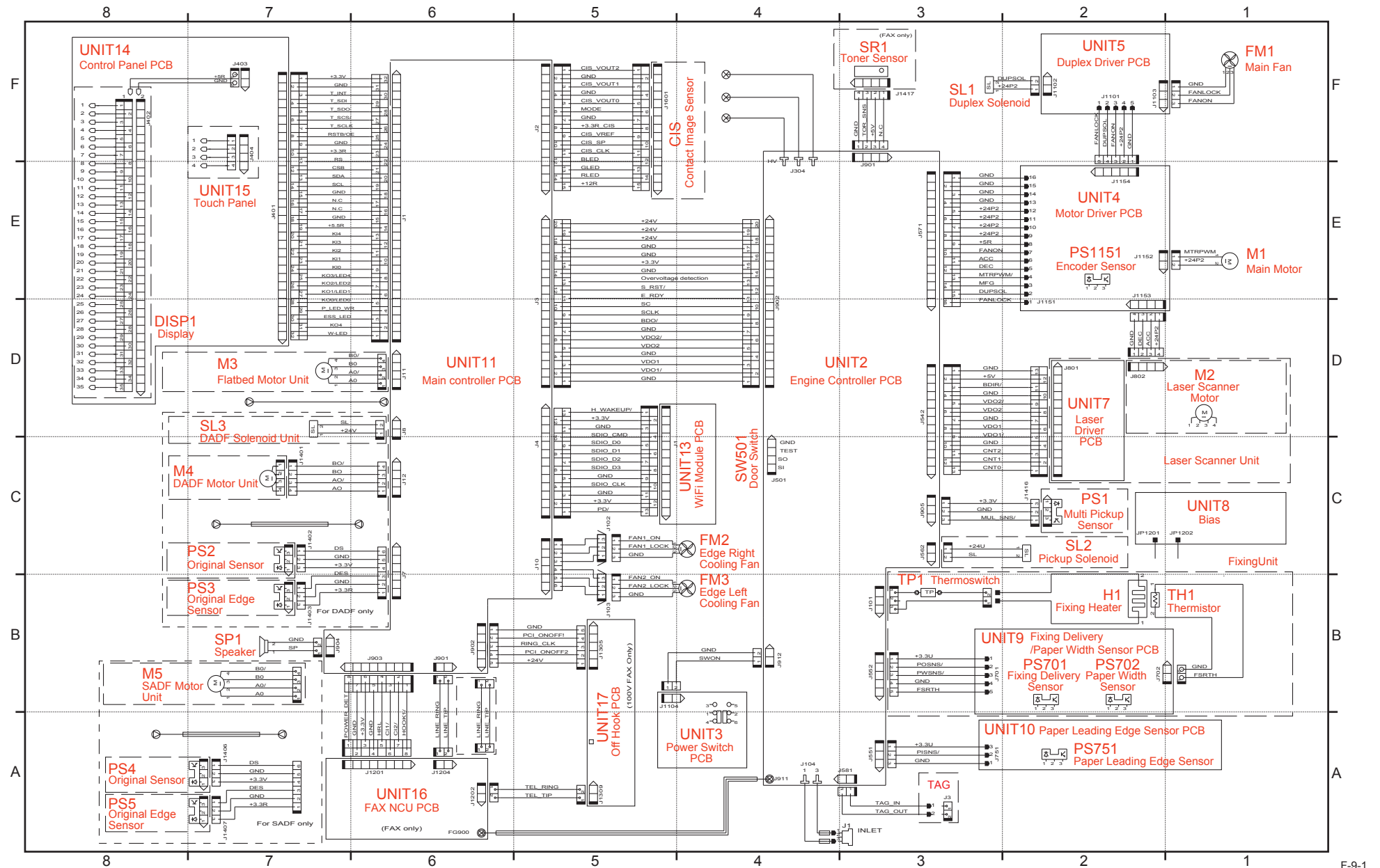

General Circuit Diagram (Simplex Model)

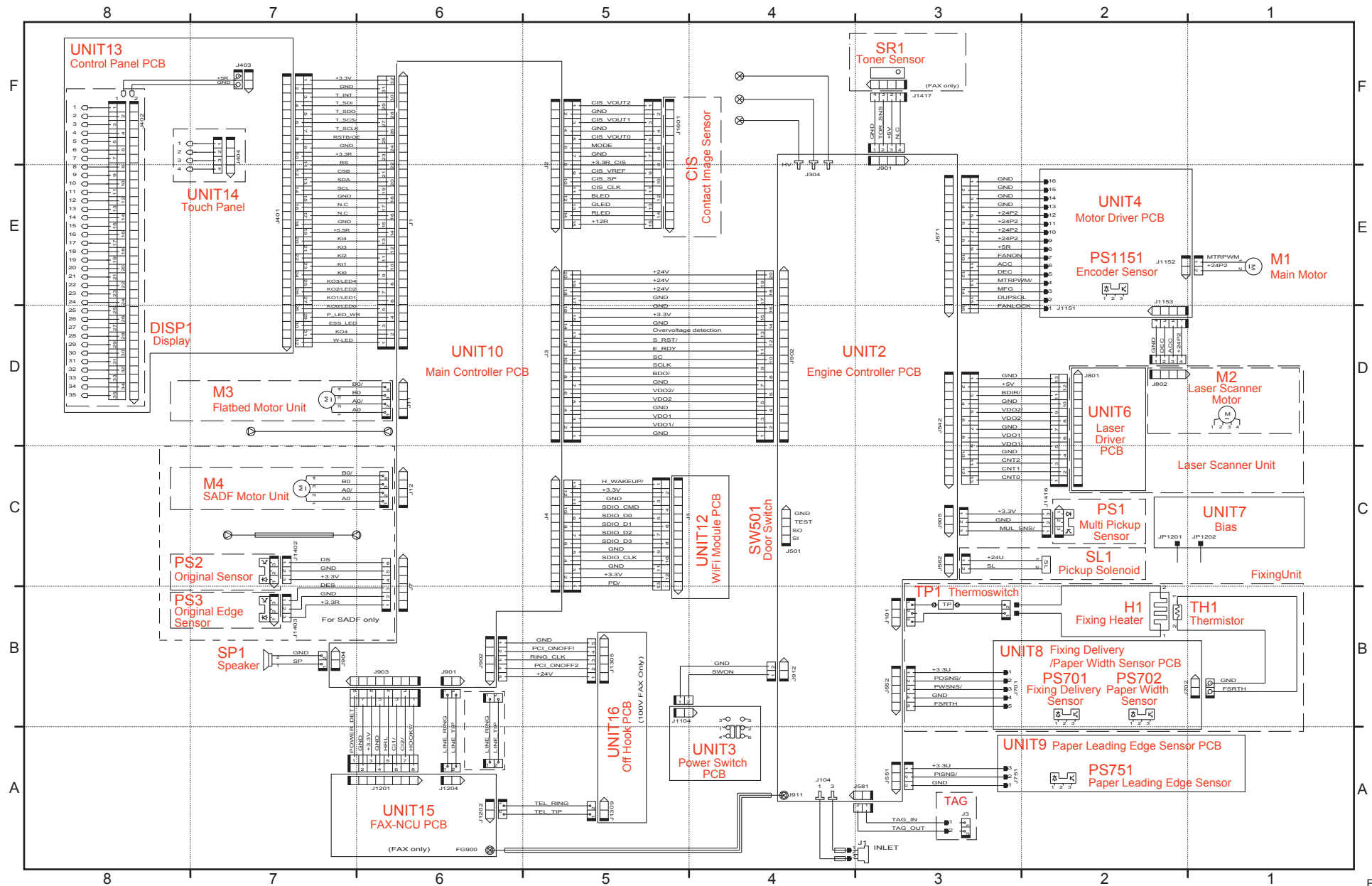

F-9-2

General Timing Chart

Print on A4 plain paper (2 pages) (Unit: second)

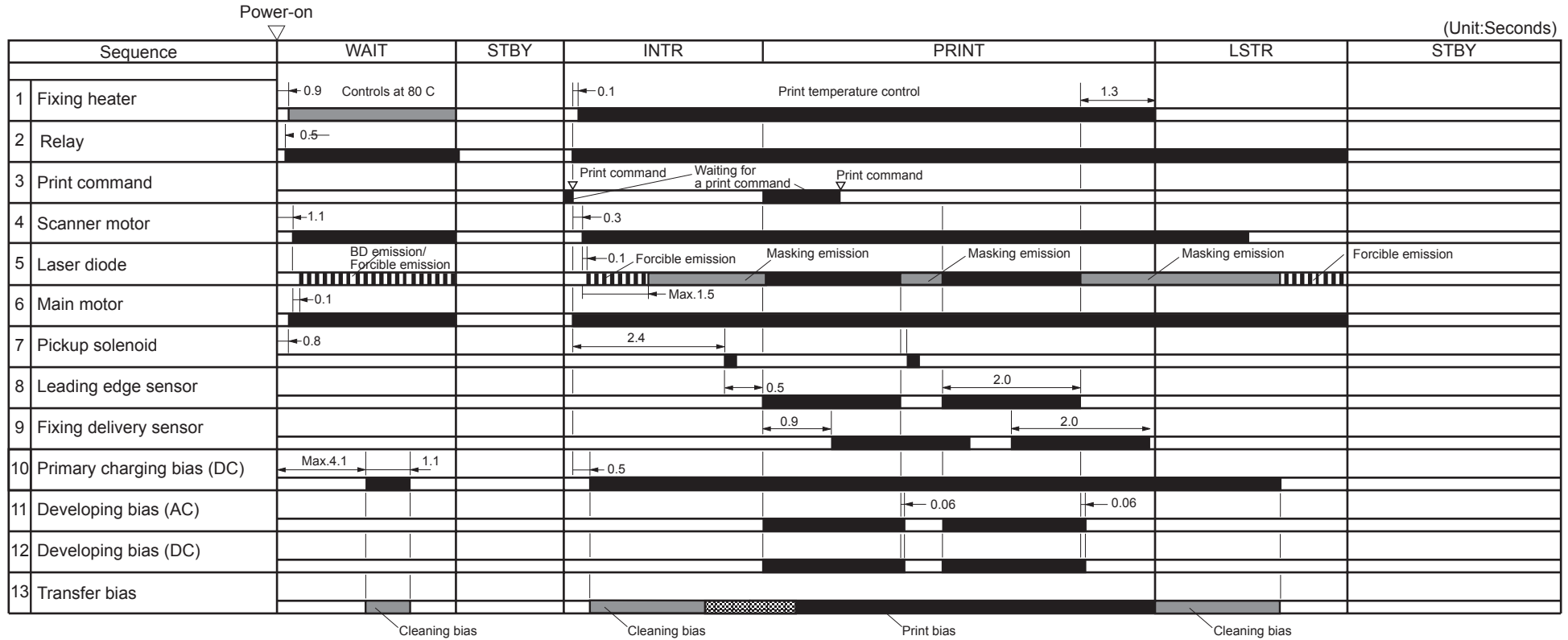

F-9-3

List of User Mode

Network Settings

*: Default Settings

Item		Setting Description	
Select Wired/Wireless LAN		Wired LAN*, Wireless LAN	
Wireless LAN Settings	WPS Push Button Mode		
	WPS PIN Code Mode		
	SSID Settings	Select Access Point	
	Enter Manually	Security Settings	
		<ul style="list-style-type: none"> None WEP <ul style="list-style-type: none"> Open System* Select WEP Key: 1/2/3/4 Edit WEP Key Shared Key <ul style="list-style-type: none"> Select WEP Key: 1/2/3/4 Edit WEP Key WPA/WPA2-PSK <ul style="list-style-type: none"> Auto*, AES-CCMP 	
	Power Save Mode	Off*, On	
	Wireless LAN Information		
	MAC Address, Wireless LAN Status, Latest Error Information, Channel, SSID Settings, Security Settings, Power Save Mode		
TCP/IP Settings	IPv4 Settings	IP Address Settings	<ul style="list-style-type: none"> Auto Acquire* <ul style="list-style-type: none"> Select Protocol <ul style="list-style-type: none"> Off, DHCP*, BOOTP, RARP Auto IP <ul style="list-style-type: none"> Off, On* Manually Acquire <ul style="list-style-type: none"> IP Address: 0.0.0.0 Subnet Mask: 0.0.0.0 Gateway Address: 0.0.0.0 Check Settings <ul style="list-style-type: none"> Auto Acquire IP Address Subnet Mask Gateway Address
		PING Command	

Item		Setting Description	
TCP/IP Settings	IPv4 Settings	DNS Settings	<ul style="list-style-type: none"> DNS Server Settings <ul style="list-style-type: none"> Primary DNS Server: 0.0.0.0 Secondary DNS Server: 0.0.0.0 DNS Host Name/Domain Name Settings <ul style="list-style-type: none"> Host Name Domain Name DNS Dynamic Update Settings <ul style="list-style-type: none"> Off*, On(DNS Dynamic Update Interval: 0 to 24* to 48 (hr.))
		mDNS Settings	Off, On* : mDNS Name
TCP/IP Settings	IPv4 Settings	DHCP Option Settings	<ul style="list-style-type: none"> Acquire Host Name <ul style="list-style-type: none"> Off, On* DNS Dynamic Update <ul style="list-style-type: none"> Off*, On
		Use IPv6	Off*, On, Check Settings
	IPv6 Settings	Stateless Address Settings	Off, On*, Check Settings
		Use DHCPv6	<ul style="list-style-type: none"> Off* On Check Settings <ul style="list-style-type: none"> Stateful Address, Prefix Length
	DNS Settings	DNS Host Name/Domain Name Settings	Use IPv4 Host/Domain <ul style="list-style-type: none"> Off Host Name Domain Name On*
		DNS Dynamic Update Settings	<ul style="list-style-type: none"> Off* On <ul style="list-style-type: none"> Register Manual Address <ul style="list-style-type: none"> Off*, On Register Stateful Address <ul style="list-style-type: none"> Off*, On Register Stateless Address <ul style="list-style-type: none"> Off*, On DNS Dynamic Update Interval <ul style="list-style-type: none"> 0 to 24* to 48 (hr.)
		mDNS Settings	<ul style="list-style-type: none"> Off On* <ul style="list-style-type: none"> Use IPv4 Name for mDNS <ul style="list-style-type: none"> Off mDNS Name On*
		LPD Print Settings	Off, On*
		RAW Print Settings	Off, On*

Item			Setting Description
TCP/IP Settings	WSD Settings	WSD Print Settings	Use WSD Print Off, On*
			Use WSD Browsing Off, On*
		WSD Scan Settings	Use WSD Scan Off*, On
			Use Computer Scan Off*, On
			Use Multicast Discovery Off, On*
		Use HTTP	Off, On*
	Port Number Settings	LPD	1 to 515* to 65535
		RAW	1 to 9100* to 65535
		WSD Multicast Discovery	1 to 3702* to 65535
		HTTP	1 to 80* to 65535
SNMP		1 to 161* to 65535	
	MTU Size	1300, 1400, 1500*	
SNMP Settings	SNMPv1 Settings		<ul style="list-style-type: none"> • Off • On* <ul style="list-style-type: none"> • Community Name 1 Settings Off, On* • Community Name 2 Settings Off*, On • Dedicated Community Settings Off, On*
	Acquire Printer Management Information from Host		Off*, On
Dedicated Port Settings			Off, On*
Waiting Time for Connection at Startup			0* to 300 (sec.)
Ethernet Driver Settings	Auto Detect		<ul style="list-style-type: none"> • Off <ul style="list-style-type: none"> • Communication Mode Half Duplex*, Full Duplex • Ethernet Type 10BASE-T*, 100BASE-TX • On*
	MAC Address		
Initialize Network Settings			

T-9-3

Preferences

*: Default Settings

*1: Different defaults depending on the country or region of purchase.

*2: Unavailable depending on the country or region of purchase.

Item		Setting Description
Sound Volume Control	Fax Tone	0 to 1* to 5
	Ring Tone	0 to 1* to 5
	TX Done Tone	0 to 1* to 5 <ul style="list-style-type: none"> • Only When Error Occurs Off*, On
	RX Done Tone	0 to 1* to 5 <ul style="list-style-type: none"> • Only When Error Occurs Off*, On
	Scanning Done Tone	0 to 1* to 5 <ul style="list-style-type: none"> • Only When Error Occurs Off*, On
	Entry Tone	Off, On*
	Invalid Entry Tone	Off*, On
	Warning Tone	Off, On*
	Job Done Tone	Off, On*
	Energy Saver Alert	Off*, On
	Original in Feeder Detection Tone*2	Off, On*
Display Settings	Default Screen after Startup/Restoration	Home*, Copy, Fax, Scan
	Home Screen Button Display Settings	
	Contrast	Five Levels
	Invert Screen Colors	Off*, On
	Millimeter/Inch Entry Switch*1	Millimeter, Inch*
	Gram/Pound Switch*2	Gram, Pound*
	Notify to Clean Original Scanning Area	Off, On*
	Message Display Time	1 to 2* to 5 (sec.)
	Scrolling Speed	Slow, Standard*, Fast
	Cursor Movement	Auto*, Manual
Language*1	English*, French, Spanish, Portuguese	
Remote UI Language*1	English*, French, Spanish, Portuguese	

T-9-4

Quiet Mode Time

*: Default Settings

*1: Different defaults depending on the country or region of purchase.

Item		Setting Description
Quiet Mode Time	Start Time	Off*, On(Start time setting to enter quiet mode)
	End Time	Off*, On(Stop time setting to exit quiet mode)
Date/Time Settings	Date Format *1	YYYY MM/DD, MM/DD/YYYY*, DD/MM YYYY
	Time Format	12 Hour (AM/PM)*, 24 Hour
	Current Date/Time Settings	
	Daylight Saving Time Settings *1	<ul style="list-style-type: none"> Off* On Start: Month, Week, Day End: Month, Week, Day
Auto Sleep Time		5* to 30 (min.)
Auto Reset Time		0 (Auto Reset is disabled.), 1 to 2* to 9 (min.)
Function After Auto Reset		Default Function*, Selected Function
Auto Offline Time		0 (The machine remains online.), 1 to 5* to 60 (min.)

T-9-5

Common Settings

*: Default Settings

Item		Setting Description
Switch Paper Feed Method	Multi-Purpose Tray	Speed Priority*, Print Side Priority
	Drawer 1	Speed Priority*, Print Side Priority

T-9-6

Copy Settings

*: Default Settings

Item		Setting Description
Change Default Settings	Number of Copies	1* to 99
	Density	-4 to 0* to +4, Auto Density
	Original Type	Text, Text/Photo (High Speed)*, Text/Photo, Photo
	2-Sided*1	Off*, 1->2-Sided, 2->2-Sided*2, 2->1-Sided*2, Original/Finishing Type
	Copy Ratio	Custom Ratio, 100% (Direct)*, 400% (Max), 200%, 129% STMT->LTR, 78% LGL->LTR, 64% LTR->STMT, 50%, 25% (Min)
	N on 1	Off*, 2 on 1, 4 on 1, ID Card Copy, Select Layout
	Collate	Off*, On
	Sharpness	Seven Levels
Correct Density		-4 to 0* to +4

T-9-7

Fax Settings

*: Default Settings

Item		Setting Description	
Basic Settings	Register Unit Telephone Number		
	Select Line Type	Pulse, Tone	
	Public Line Connection	Direct*, Adapter 1, Adapter 2	
	Off-Hook Alarm	0* to 5	
	Communication Management Settings	TX Start Speed	33600 bps*, 14400 bps, 9600 bps, 7200 bps, 4800 bps, 2400 bps
RX Start Speed		33600 bps*, 14400 bps, 9600 bps, 7200 bps, 4800 bps, 2400 bps	
TX Function Settings	Change Default Settings	Resolution	200 x 100 dpi (Normal)*, 200 x 200 dpi (Fine), 200 x 200 dpi (Photo), 200 x 400 dpi (Superfine)
		Density	Nine Levels
		2-Sided Original	Off*, Book Type, Calendar Type
		Sharpness	Seven Levels
	Register Unit Name		
ECM TX	Off, On*		
Set Pause Time	1 to 2* to 15 (sec.)		
Auto Redial	<ul style="list-style-type: none"> Off On* <ul style="list-style-type: none"> No. of Times to Redial 1 to 2* to 10 (times) Redial Interval 2* to 99 (min.) Redial When Err Occurs Off, On* 		
TX Terminal ID	<ul style="list-style-type: none"> Off On* <ul style="list-style-type: none"> Print Position Inside Image Area, Outside Image Area* Mark No. as: TEL/FAX FAX*, TEL 		
Check Dial Tone Before Sending	Off*, On		
Allow Fax Driver TX	Off, On*		
Confirm Entered Fax Number	Off*, On		
ECM RX	Off, On*		
RX Function Settings	Incoming Ring	<ul style="list-style-type: none"> Off On* 1 to 2* to 99 (times)	
	Remote RX	<ul style="list-style-type: none"> Off On* 00 to 25* to 99	
	Switch to Auto RX	<ul style="list-style-type: none"> Off* On 1 to 15* to 99 (sec.)	

Item		Setting Description
RX Function Settings	Memory Lock Settings	<ul style="list-style-type: none"> Off* On <ul style="list-style-type: none"> Memory Lock PIN Report Print Off, On* Memory Lock Time Off*, On(Memory Lock Start Time, Memory Lock End Time)
	Print on Both Sides	Off*, On
RX Print Settings	Reduce RX Size	<ul style="list-style-type: none"> Off On* <ul style="list-style-type: none"> Reduction Ratio Auto*, 97%, 95%, 90%, 75% Reduction Direction Vertical/Horizontal, Vertical Only*
	RX Page Footer	Off*, On
	Continue Print. When Near Cart. Life End	Off*, On
Fax Setup Guide		

T-9-8

Scan Settings

*: Default Settings

Item			Setting Description
Shortcut Key Settings	Register	Scan -> PC1	<ul style="list-style-type: none"> Off* USB Connection Color Scan, B&W Scan, Custom 1, Custom 2 Network Connection Color Scan, B&W Scan, Custom 1, Custom 2
		Scan -> PC2	<ul style="list-style-type: none"> Off* USB Connection Color Scan, B&W Scan, Custom 1, Custom 2 Network Connection Color Scan, B&W Scan, Custom 1, Custom 2
	Confirm Destination		Scan -> PC1, Scan -> PC2

T-9-9

Printer Settings

*: Default Settings

Item	Setting Description
Action When Paper Size Mismatch	Force Output, Display Error*
Mobile Print Halftones	Gradation*, Error Diffusion
AirPrint Speed/Image Quality Priority	Speed Priority, Image Quality Priority*

T-9-10

Adjustment/Maintenance

*: Default Settings

Item		Setting Description	
Toner Save	Copy	Off*, On	
	Fax	Off*, On	
Special Processing	Special Mode U	Off*, On	
	Special Mode V	Off*, Mode 1, Mode 2, Mode 3	
	Special Mode Z	Copy	Off, Mode 1, Mode 2*, Mode 3, Mode 4
		Fax	Off, Mode 1, Mode 2*, Mode 3, Mode 4
	Special Mode B	Off*, Mode 1, Mode 2, Mode 3	
	Special Mode C	Off*, On	
	Special Mode D	Copy	Off*, On
		Print	Off*, On
	Special Mode I	Off*, On	
	Special Mode J	Off*, On	
Special Mode K	Off*, On		
Clean Fixing Assembly			

T-9-11

System Management Settings

*: Default Settings

Item		Setting Description
System Manager Information Settings		
System Manager Information Settings	System Manager PIN	
	System Manager Name	
Device Information Settings		Device Name Location
Security Settings	IPv4 Address Filter	Off*, On
	IPv6 Address Filter	Off*, On
	MAC Address Filter	Off*, On
Select Country/Region		United States (US)*, Canada (CA), Brazil (BR), Mexico (MX), Other
Remote UI Settings	Use Remote UI	Off, On*
Auto Online for Remote Scan		Off, On*
Restrict TX Function	Address Book PIN	
	Restrict New Destinations	Off*, On
	Restrict Resending from Log	Off*, On
	One-Touch/Coded Dial TX Confirmation	Off*, On
	Restrict Sequential Broadcast	Off*, Confirm Sequential Broadcast, Reject Sequential Broadcast
Display Job Log		Off, On*

Item		Setting Description
Use as USB Device		Off, On*
Enable Product Extended Survey Program		Off, On*
Displ. Consmbls. Info (RUI/Toner Status)	Displ. Consumables Purchase Button (RUI)	Off, On*
	Toner Status Settings	<ul style="list-style-type: none"> • Off • On* Displ. Purchase Button Off, On*
Import/Export Address Book		
PDL Selection (Plug and Play)	Network	FAX, UFR II LT*, UFR II LT (XPS)
	USB	UFR II LT, UFR II LT (XPS)
Update Firmware		<ul style="list-style-type: none"> • Via PC • Via Internet • Version Information
Initialize Address Book		
Initialize System Management Settings		<ul style="list-style-type: none"> • Network Settings • System Manager Information Settings • Device Information Settings • Security Settings • Remote UI Settings • Auto Online for Remote Scan • Restrict TX Function Display Job Log • Use as USB Device • Enable Product Extended Survey Program • Displ. Consmbls. Info (RUI/Toner Status) • PDL Selection (Plug and Play) • Initialize All
Initialize All Data/Settings		

T-9-12

Backup Data

Data		Replacement Controller PCB*1	CLEAR																	Backup	
			Menu > Initialize Menu									Menu > System Management Settings			COPIER > FUNCTION > CLEAR					User	Service
			Preferences	Timer Settings	Common Settings	Copy Settings	Fax Settings	Scan Settings	Printer Settings	Adjust- ment/ Mainte- nance	Initialize All	Initialize System Management Settings	Initializing Address Book	Initialize All Data/ Settings	TEL- USER	SRVC- DAT	HIST *2	PWD- CLEAR	ALL	Yes/No	Yes/No
Menu	Network Settings	Clear	-	-	-	-	-	-	-	-	-	Clear	-	Clear	Clear	-	-	-	Clear	No	No
	Preferences	Clear	Clear	-	-	-	-	-	-	-	Clear	-	-	Clear	Clear	-	-	-	Clear	No	No
	Timer Settings	Clear	-	Clear	-	-	-	-	-	-	Clear	-	-	Clear	Clear	-	-	-	Clear	No	No
	Common Settings	Clear	-	-	Clear	-	-	-	-	-	Clear	-	-	Clear	Clear	-	-	-	Clear	No	No
	Copy Settings	Clear	-	-	-	Clear	-	-	-	-	Clear	-	-	Clear	Clear	-	-	-	Clear	No	No
	Fax Settings	Clear	-	-	-	-	Clear	-	-	-	Clear	-	-	Clear	Clear	-	-	-	Clear	No	No
	Scan Settings	Clear	-	-	-	-	-	Clear	-	-	Clear	-	-	Clear	Clear	-	-	-	Clear	No	No
	Printer Settings	Clear	-	-	-	-	-	-	Clear	-	Clear	-	-	Clear	Clear	-	-	-	Clear	No	No
	Adjustment/ Maintenance	Clear	-	-	-	-	-	-	-	Clear	Clear	-	-	Clear	Clear	-	-	-	Clear	No	No
	System Management Settings	Clear	-	-	-	-	-	-	-	-	-	Clear	-	Clear	Clear	-	-	Clear *3	Clear *3	No	No
	Initialize Menu	Clear	-	-	-	-	-	-	-	-	Clear	-	-	Clear	Clear	-	-	-	Clear	No	No
Output Rprt.	-	-	-	-	-	-	-	-	-	-	-	-	-	-	-	-	-	-	No	No	
Logs	Clear	-	-	-	-	-	-	-	-	-	-	-	Clear	-	-	Clear	-	Clear	No	No	
Reader / ADF Adjustment Settings	Clear	-	-	-	-	-	-	-	-	-	-	-	-	-	Clear	-	-	-	No	No	
Service Mode Settings	Clear	-	-	-	-	-	-	-	-	-	-	-	-	Clear	-	-	-	Clear	No	No	
Serial Number	Clear	-	-	-	-	-	-	-	-	-	-	-	-	-	-	-	-	-	No	No	
Address Book	Clear	-	-	-	-	-	-	-	-	Clear	-	Clear	Clear	Clear	-	-	-	Clear	Yes *4	No	

T-9-13

*1. Log data such as Mac address, USB serial number, printer-related setting values, scanner-related setting values, user data, and logs are initialized.

*2. The logs (print, jam, error, and alarm) are cleared.

*3. The system administrator ID and the password are changed back to the default values. <Manager ID: 7654321 / PIN: 7654321>

*4. Method: Remote UI, Location: PC