



# Profiler™

COST-EFFECTIVE PROFILE MEASUREMENT

Short Range Distance Sensors (Displacement)

**SICK**  
Sensor Intelligence.

## PROFILER™ – IMPRESSIVE ALL ROUND

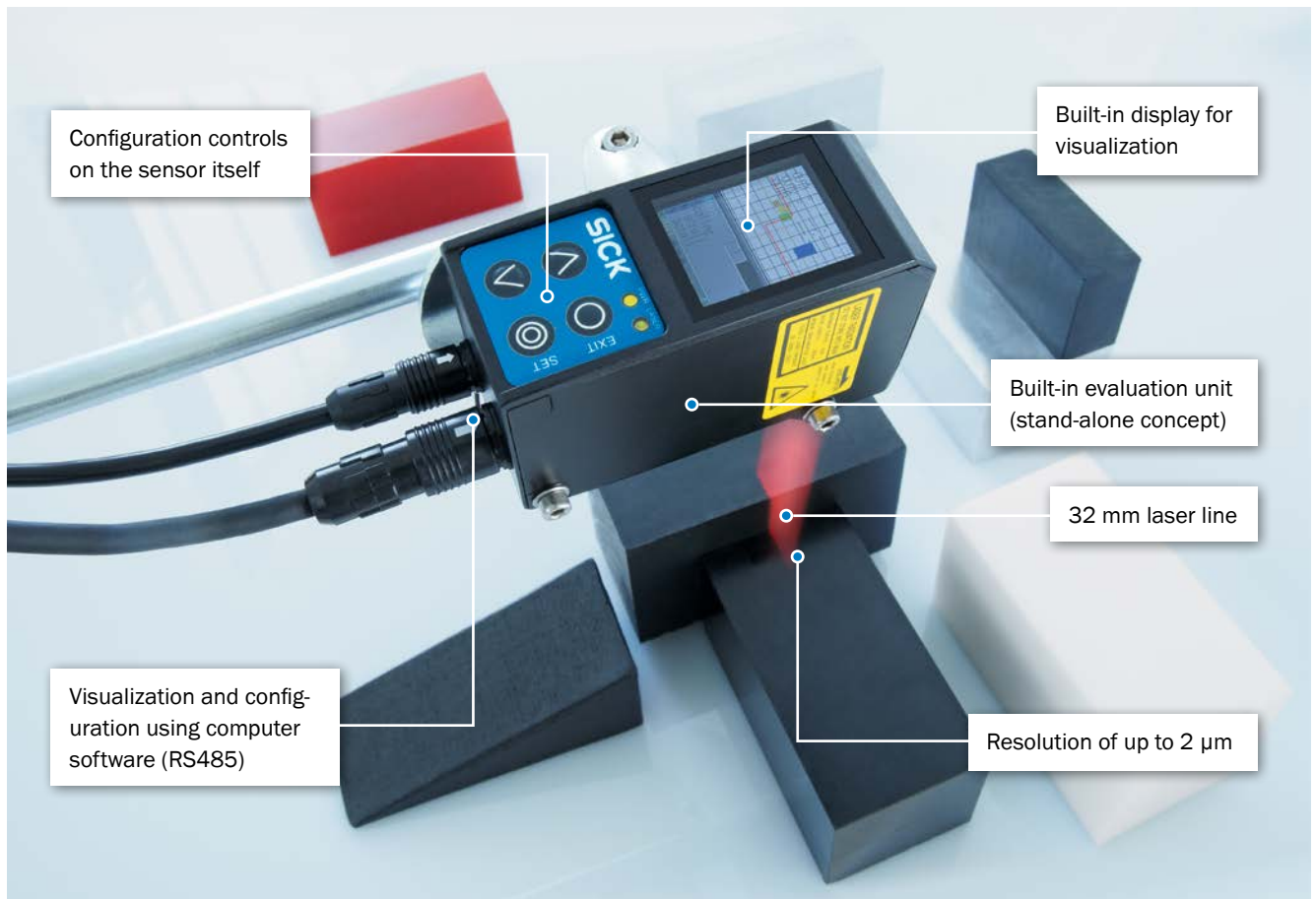

The Profiler™ can really fulfill its performance potential when used for the precise measurement of two-dimensional surface profiles. Up to four areas can be detected, analyzed and offset against one another using one single measurement of the x- and z-axes, all to a very high level of accuracy. The user can choose from more than 10 built-in measuring functions, thus covering nearly all surface measurement tasks. Thanks to the stand-alone concept of the Profiler™, no additional evaluation unit is required. This saves time and money during installation. The provided software enables easy commissioning and excellent visualization of the measurement results. In addition, the built-in LCD color screen with controls enables configuration and visualization of the application on the production line itself. With these functions, the Profiler™ is able to impress all round.

### Examples of built-in measuring functions

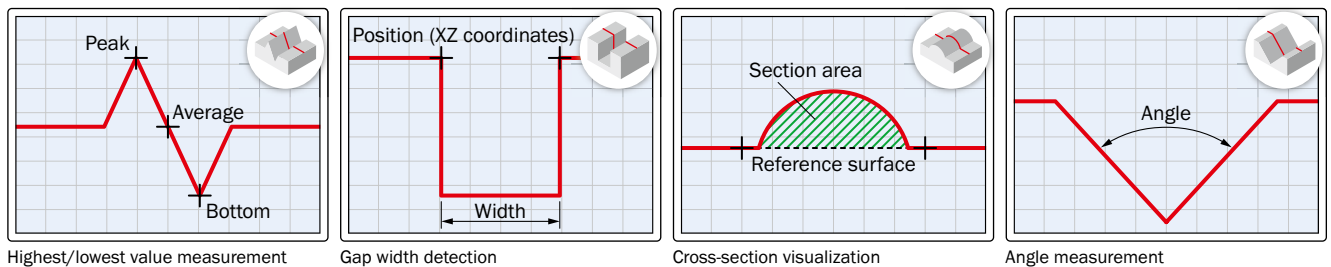

### Technology and operation

The principle of operation of the Profiler™ is based on the 2D triangulation process. The sensor's laser light ① is projected as a laser line onto the object to be measured. The reflected light is projected from the lens onto the CMOS receiver element ②, thus enabling profiling. In order to detect the horizontal position of the object, the camera image is evaluated and transformed in the sensor, then visualized in the form of a generated profile on the built-in LCD screen ③ or on a computer using the provided software ④.

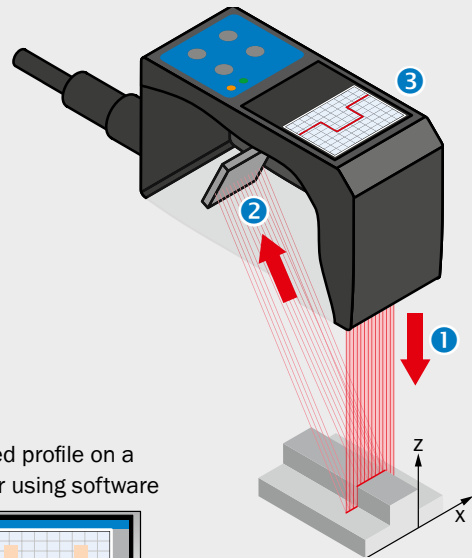

② Camera image

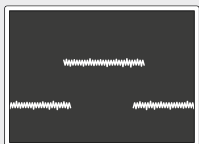

Transformation

③ Generated profile on the LCD screen

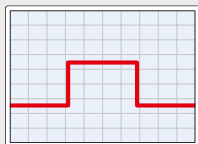

④ Generated profile on a computer using software

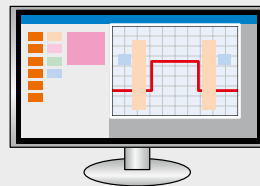

### Typical industries and fields of application

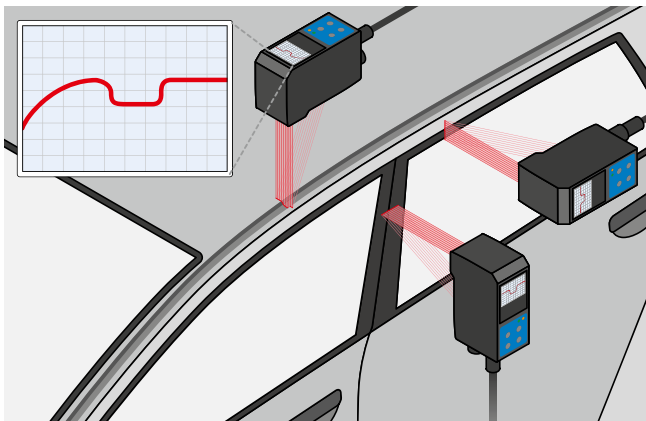

Automotive industry – multiple edge and door gap detection

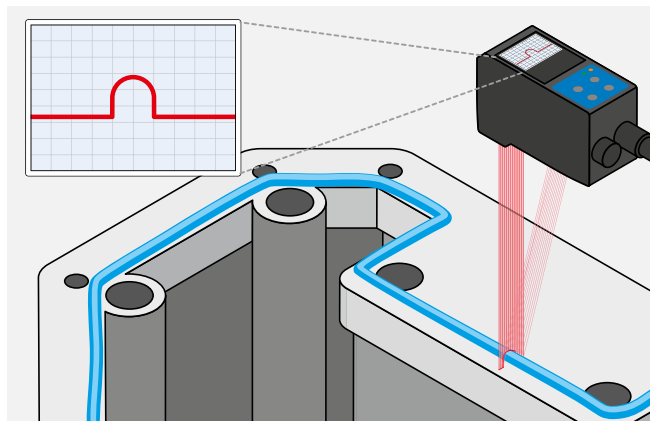

Industrial assembly – monitoring of adhesive quantities in the assembly process

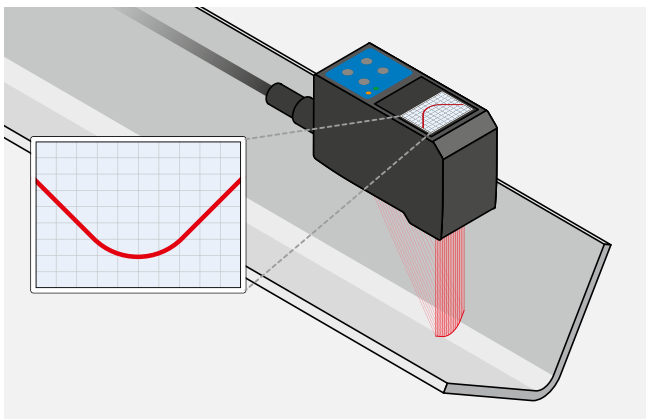

Processing industry – monitoring of bend radii or gaps in sheet metal

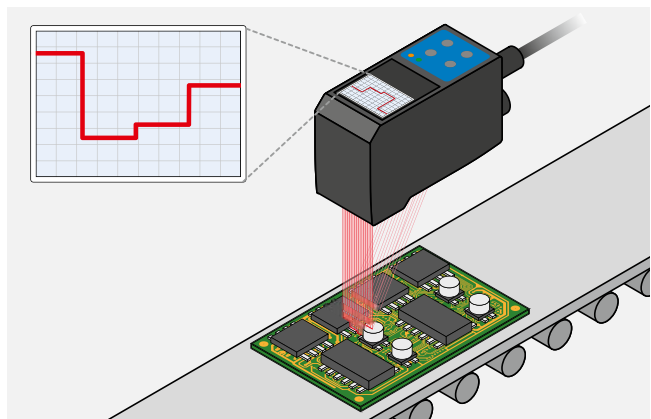

Electronics industry – monitoring of length and height geometries, for example in the case of a printed circuit board

# COST-EFFECTIVE PROFILE MEASUREMENT

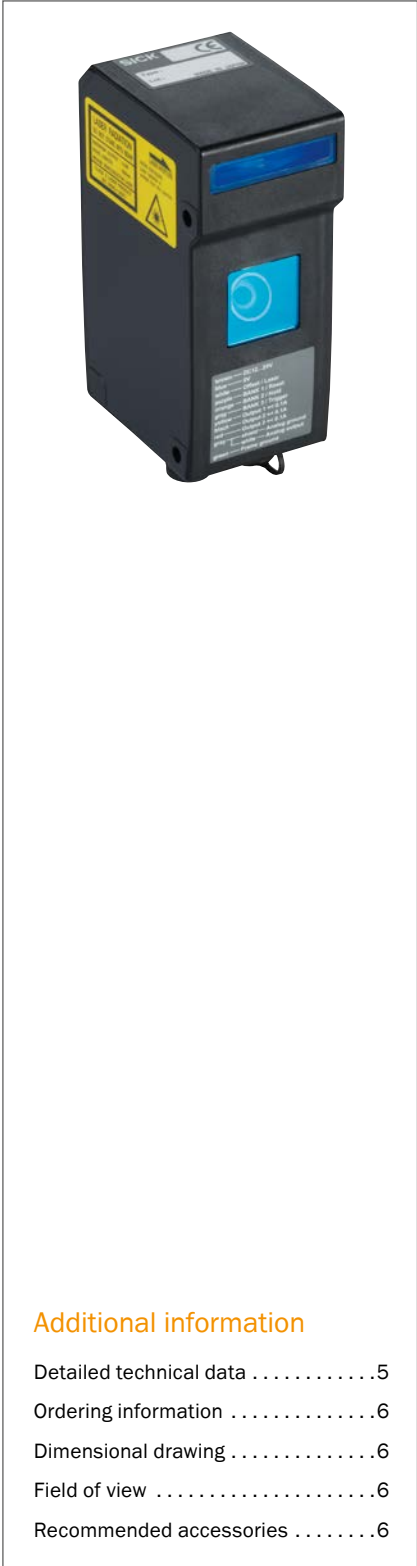

## Product description

The Profiler™ short range distance sensor performs highly accurate measurements on the x and z axes and can also measure the surface of more complex objects. Up to four areas can be analyzed at the same time with a single measurement. One of the 10 integrated measurement functions, e.g., height or width, can be selected for each area. The integrated evaluation unit of the Profiler™ saves you time and money

when it comes to installation – making the sensor one of the most cost-effective solutions for profile measurement. While the integrated CMOS receiver unit guarantees precise measuring, the supplied software makes commissioning simple and provides exceptional visualization of the measurement process. The integrated LC display offers real-time visualization.

## At a glance

- Measure complex profiles with just one laser line
- Analyze up to four areas at the same time
- More than 10 integrated measurement functions, e.g., height, width, and inclination
- Sensor head and evaluation unit in one device
- Commissioning via software or integrated display with operating elements
- High-quality CMOS receiver unit

## Your benefits

- Measuring a 2D profile with just one sensor saves on hardware and installation costs
- Cost-effective solution for 2D profile measurement
- Real-time visualization of the measurement results via the integrated LC display
- Intuitive and quick commissioning via the software or display reduces installation time
- Thanks to the stand-alone concept of the Profiler™, there is no need for cabling or to mount an additional evaluation unit
- Reliable measuring regardless of color, material, or shape
- More than 10 integrated measurement functions allow profiles to be measured and analyzed quickly

## Additional information

Detailed technical data . . . . .	5
Ordering information . . . . .	6
Dimensional drawing . . . . .	6
Field of view . . . . .	6
Recommended accessories . . . . .	6

→ [www.mysick.com/en/Profiler](http://www.mysick.com/en/Profiler)

For more information, just enter the link or scan the QR code and get direct access to technical data, CAD design models, operating instructions, software, application examples and much more.



## Detailed technical data

## Performance

<b>Measuring range</b>	75 ... 125 mm
<b>Measuring range (at measuring distance)</b>	17 mm (75 mm) / 22 mm (100 mm) / 27 mm (125 mm)
<b>Resolution (R) <sup>1)</sup></b>	In x-direction: 25 µm (for details see "Field of view" on page 6) In z-direction: 2 µm
<b>Linearity</b>	In x-direction: ± 1 % FS <sup>2)</sup> , ± 170 µm <sup>3)</sup> In z-direction: ± 0.1 % FS <sup>2)</sup> ± 50 µm
<b>Response time</b>	5 ms <sup>4)</sup>
<b>Light source</b>	Laser, red <sup>5)</sup>
<b>Laser class</b>	2 (EN 60825-1, FDA)

<sup>1)</sup> Typical value; real value depends on ambient conditions and settings.

<sup>2)</sup> FS = Full scale (entire measuring range).

<sup>3)</sup> At 75 mm measuring range.

<sup>4)</sup> Typical value, hi-res mode.

<sup>5)</sup> Wave length 655 nm, max. output 1 mW.

## Interfaces

<b>Analog output</b>	1 x 4 mA ... 20 mA (< 300 Ω) <sup>1)</sup>
<b>Data interface</b>	RS-485 <sup>2)</sup>
<b>External input</b>	Selectable from bank, trigger, hold, reset, laser off and offset

<sup>1)</sup> 24 mA for measuring out of range.

<sup>2)</sup> f-duplex (9.6 kbit/s ... 4 Mbit/s).

## Mechanics/electronics

<b>Dimensions</b>	40 mm x 60 mm x 94.5 mm
<b>Supply voltage</b>	12 V DC (- 5 %) ... 24 V DC (+ 10 %) <sup>1)</sup>
<b>Weight</b>	Approx. 300 g

<sup>1)</sup> When using the analog output: DC 18 V (-5 %) to DC 24 V (+10 %).

## Ambient data

<b>Protection class</b>	IP 67
<b>Operating temperature</b>	-10 °C ... +40 °C (operation) -20 °C ... +60 °C (storage)

## Ordering information

Switching outputs	Model name	Part no.
3 x PNP	PRO2-P100B25A1	6052873
3 x NPN	PRO2-N100B25A1	6052874

## Dimensional drawing (dimensions in mm (inch))

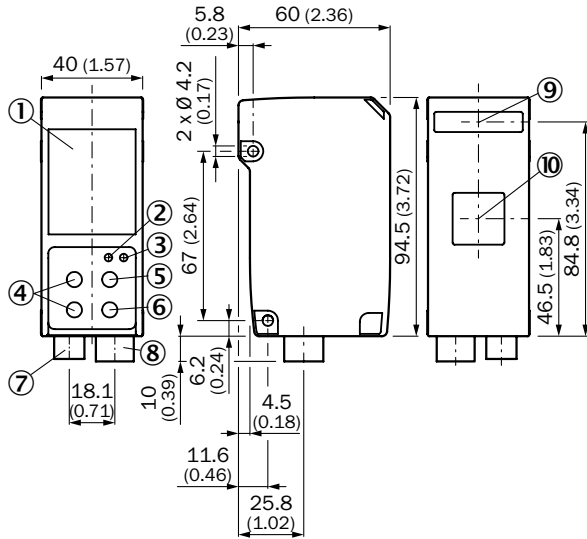

- ① LCD display
- ② LED indicator for power on (green)
- ③ LED indicator for laser on (green)
- ④ Cursor keys
- ⑤ EXIT button
- ⑥ SET button
- ⑦ Male connector, HRS, 6-pin (communication interface)
- ⑧ Female connector, HRS, 12-pin (I/O, power supply)
- ⑨ Sender
- ⑩ Receiver

## Field of view

### Sensing area

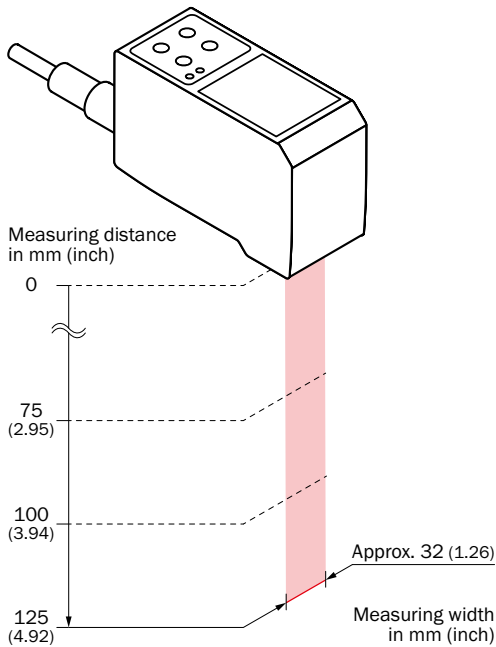

### Receiving area

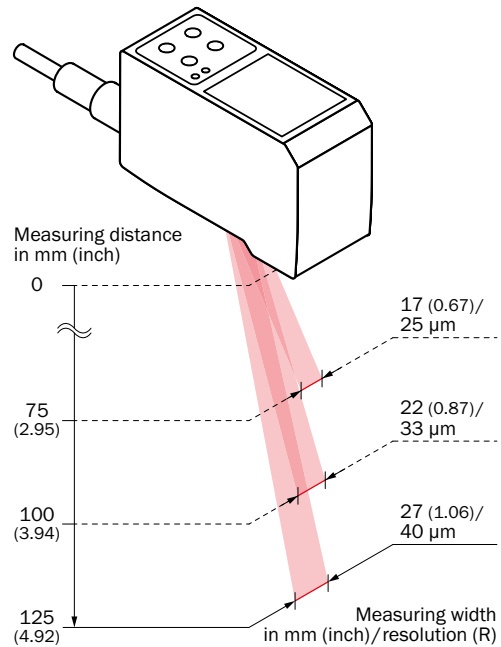

## Recommended accessories

### Plug connectors and cables

Figure	Description	Length of cable	Model name	Part no.
	Male cable connector, Hirose, 12 pin, straight, with open end	2 m	STL-0H12-G02M	6053017
		5 m	STL-0H12-G05	6053018
		10 m	STL-0H12-G10M	6053019
	Communication cable with USB (for PC connection)	1.8 m	DSL-DH06-G1M8	6053020
	Communication cable with open end (discrete wire)	2 m	DOL-SH06-G02M	6053021
		5 m	DOL-SH06-G05M	6053196
		10 m	DOL-SH06-G10M	6053197

## WWW.MYSICK.COM – SEARCH ONLINE AND ORDER

Search online quickly and safely – with the SICK “Finders”

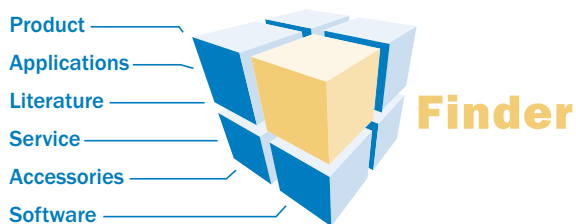

**Product Finder:** We can help you to quickly target the product that best matches your application.

**Applications Finder:** Select the application description on the basis of the challenge posed, industrial sector, or product group.

**Literature Finder:** Go directly to the operating instructions, technical information, and other literature on all aspects of products from SICK.

These and other “Finders” at → [www.mysick.com](http://www.mysick.com)

Efficiency – with the e-commerce tools from SICK

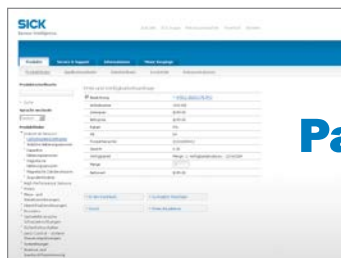

**Find out prices and availability:** Determine the price and possible delivery date of your desired product simply and quickly at any time.

**Request or view a quote:** You can have a quote generated online here. Every quote is confirmed to you via e-mail.

**Order online:** You can go through the ordering process in just a few steps.

## SERVICES FOR MACHINES AND SYSTEMS: SICK LifeTime Services

Our comprehensive and versatile LifeTime Services are the perfect addition to the comprehensive range of products from SICK. The services range from product-independent consulting to traditional product services.



**Consulting & Design**  
Safe and professional



**Product & System Support**  
Reliable, fast and on-site



**Verification & Optimization**  
Safe and regularly inspected



**Upgrade & Retrofits**  
Easy, safe, economical



**Training & Education**  
Practical, focused and professional

## SICK AT A GLANCE

SICK is a leading manufacturer of intelligent sensors and sensor solutions for industrial applications. With more than 6,500 employees and over 50 subsidiaries and equity investments as well as numerous representative offices worldwide, we are always close to our customers. A unique range of products and services creates the perfect basis for controlling processes securely and efficiently, protecting individuals from accidents and preventing damage to the environment.

We have extensive experience in various industries and understand their processes and requirements. With intelligent sensors, we can deliver exactly what our customers need. In application centers in Europe, Asia and North America, system solutions are tested and optimized in accordance with customer specifications. All this makes us a reliable supplier and development partner.

Comprehensive services round out our offering: SICK LifeTime Services provide support throughout the machine life cycle and ensure safety and productivity.

**For us, that is “Sensor Intelligence.”**

### **Worldwide presence:**

Australia, Austria, Belgium/Luxembourg, Brazil, Czech Republic, Canada, China, Denmark, Finland, France, Germany, Great Britain, Hungary, India, Israel, Italy, Japan, Mexico, Netherlands, Norway, Poland, Romania, Russia, Singapore, Slovenia, South Africa, South Korea, Spain, Sweden, Switzerland, Taiwan, Turkey, United Arab Emirates, USA

Detailed addresses and additional representatives → [www.sick.com](http://www.sick.com)