



This Datasheet is for the

[IC693APU305](#)

I/O Processor Module

<http://www.qualitrol.com/shop/p-14581-ic693apu305.aspx>

Provides the wiring diagrams and installation guidelines for this GE Series 90-30 module.

For further information, please contact Qualitrol Technical Support at

1-800-784-9385

support@qualitrol.com

IC693APU305 I/O Processor Module

The I/O Processor (IOP) module (IC693APU305) for the Series 90-30 PLC provides direct processing of rapid pulse signals for industrial control applications such as:

- Fast response process control
- Velocity measurement
- Material handling, marking, and packaging

Direct processing means that the module is able to sense inputs, process the input information, and control the outputs without needing to communicate with a CPU.

During each CPU sweep, the I/O Processor communicates with the CPU through 32 discrete inputs (%I), 15 words of analog inputs (%AI), 32 discrete outputs (%Q), and 6 words of analog outputs (%AQ). The %AQ outputs can be used by the CPU program to set up timer values or send other controlling parameters to the I/O Processor.

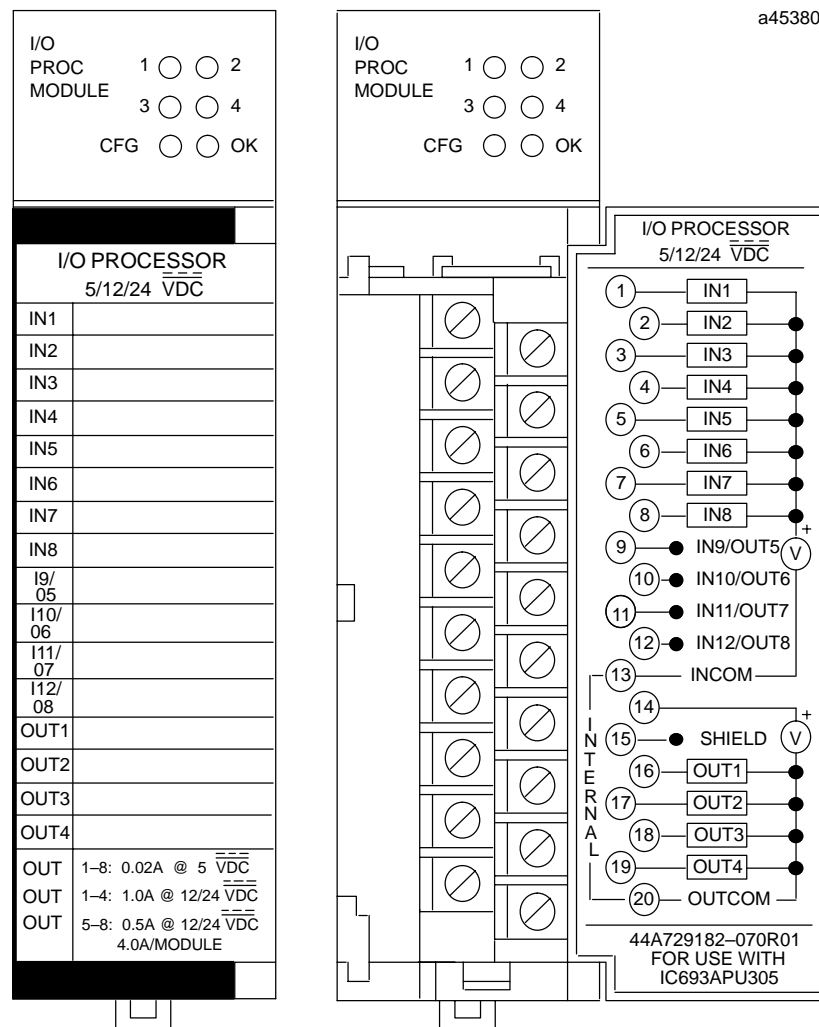

Figure 8-17. I/O Processor Module

The I/O Processor is configured using the Series 90-30 Hand-held Programmer, Logicmaster 90-30, or VersaPro software. Many configuration parameters can be

modified from the user's application program as well. Each configuration parameter is set to a factory default value which is suitable for many applications. There are no jumpers or DIP switches to set on the module. Six green LEDs at the top of the module indicate the operating status of the module, the status of configuration parameters, and the state of hardware outputs 1 through 4.

Module Features

Module features include:

- Up to 12 positive logic (source) inputs with input voltage range selection of either 5 VDC (TTL) or 10 to 30 VDC (non-TTL).
- Up to eight positive logic (source) outputs: four outputs with 1 amp rating and four configurable outputs with 0.5 amp rating
- Outputs protected by replaceable fuse (one fuse common to all outputs)
- Dedicated processor provides 500 μ s I/O update
- Counts per Timebase register for input rate measurement
- Total Counts register (32-bit) accumulates total counts received by module
- Four Strobe data registers for input position capture
- Two Timer data registers for indicating input pulse length or input spacing in milliseconds
- Thirty-two range comparators (outputs returned in %I and %AI data)
- Software configuration
- Internal module diagnostics
- Individual LEDs that indicate Module OK and Configured OK status
- Individual LEDs that indicate state of Outputs 1 through 4
- A removable terminal board for connection of field wiring.

Inputs can be used as count signals or edge-sensitive strobe signals. Outputs can be used to drive indicating lights, solenoids, relays, and other devices.

Power to operate the module's logic circuitry is obtained from the 5 VDC bus on the baseplate backplane. Power sources for the input and output devices must be supplied by the user or by the +24 VDC isolated output of the Series 90-30 power supply. The I/O Processor module provides a selectable threshold voltage to allow the inputs to respond to either a 5 VDC signal level or a 10 to 30 VDC signal level. The threshold is selected by configuration.

All configuration parameters for the module are downloaded from the PLC to the I/O Processor after it passes its internal diagnostics. Once the module has been successfully configured, the CONFIG OK LED will turn on. Configuration parameters can be changed using Logicmaster 90-30 programming software configuration software or the Hand-Held Programmer.

Operation of the I/O Processor module is monitored by a watchdog timer circuit. If the watchdog timer detects a module failure, it will force all outputs off and turn off the MODULE OK LED.

I/O Processor Module Documentation

Please refer to publication GFK-1028, *Series 90-30 I/O Processor User's Manual*.